

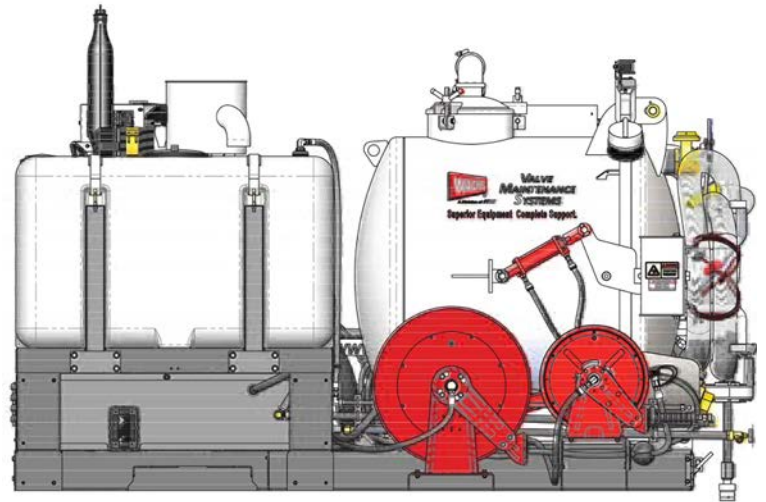

E.H. Wachs
600 Knightsbridge Parkway
Lincolnshire, IL 60069
www.ehwachs.com

Standard LX and Builder Valve Maintenance Skid System User's Manual



E.H. Wachs Part No. 77-MAN-03
Rev. A, August 2020

Revision History:
Original August 2020

Copyright © 2020 E.H. Wachs. All rights reserved.
This manual may not be reproduced in whole or in part
without the written consent of E.H. Wachs.

Table of Contents

Chapter 1: About the Standard VM Skid System	1
Purpose of This Manual	1
How to Use The Manual	1
Symbols and Warnings	2
Manual Updates and Revision Tracking	3
Equipment Description	3
Standard LX Skid Systems	4
Standard Builder Skid Systems	10
Engine Specifications	18
Diesel Engine (Configurations 77-000-54 and 77-000-60)	18
Gas Engine (Configuration 77-000-55 and 77-000-61)	19
Hydraulic Power System	19
Vacuum System	19
Pressure Washer	20
Hydraulic Hose Reel	20
ERV-750 Extended Reach Valve Operator	20
TM-7 Automated Valve Exerciser (Optional)	21
Water Heater (Optional)	22
Dismantling and Disposal	23
Hydraulics and Lubricants	23
Machinery and Components	23
System Component Manuals	23
Chapter 2: Safety	25
Safe Operating Guidelines	25
Safe Operating Environment	26
Safety Alerts in This Manual	27
Protective Equipment Requirements	27
Protective Clothing	27
Eye Protection	28
Hearing Protection	28
Safe Operation of the VMS	28
Proper Use of the VMS	28
Hydraulic Powered Equipment	28
Misuse of Equipment	29
Potential Hazards	29
Residual Risks	30
Disconnecting Power	30
Chapter 3: Installation	31
Installation Overview	31
Schematics	34

Standard LX Diesel (77-000-54) 35
 Standard LX Gas (77-000-55) 36
 Standard Builder Diesel (77-000-60) 37
 Standard Builder Gas (77-000-61) 39

Chapter 4: Operating Instructions 41
 Curbside Control Panel 41
 Diesel Engine Configurations (77-000-54/60) 42
 Gas Engine Configurations (77-000-55/61) 43
 Engine Operation 44
 Diesel Engine Starting and Operation 46
 Gas Engine Starting and Operation 46
 Hydraulic System Controls 47
 ERV-750 Operation 47
 Vacuum Operation 48
 Selecting a Vacuum Wand 48
 Setup and Operation 49
 Emptying the Tank 55
 Draining Liquid 56
 Dumping Solids 57
 Lubricating the Blower 61
 Unclogging the Vacuum 64
 Pressure Washer Operation 65
 Filling the Water Tank 67
 Filling the Antifreeze (Primer) Tank 67
 Using the Pressure Washer 68
 Priming the Washer Pump 73
 Prime Using the Pump Pressure 73
 Recirculation 76
 Light Bar Operation 78
 Auxiliary Hydraulic Circuit/Hose Reel Operation 80
 TM-7 Operation (Optional) 81
 Water Heater Operation (Optional) 82
 Connecting/Bypassing the Water Heater 83
 Starting and Running the Water Heater 84
 Spraying Hot Water 86

Chapter 5: Maintenance 87
 Lubrication and Fluid Maintenance 87
 Mechanical Grease Fittings 87
 Pressure Washer Pump 88
 Blower 89
 Lubricating the Blower 89
 Engine 92
 Diesel Engine 92

Gas Engine	92
Replacing Fuses	93
Servicing the Drive Belts	94
Vacuum Blower Belts	94
Sprayer Pump Belts	96
Adjusting the Tank Latches	98
Valve Operators	102
ERV-750	102
TM-7	102
Cold Weather Preparation and Service	102
Chapter 6: Parts List and Ordering Information	105
Ordering Information	105
Ordering Replacement Parts	105
Repair Information	105
Warranty Information	106
Return Goods Address	106
Drawings and Parts Lists	106

Chapter 1

About the Standard VM Skid System

PURPOSE OF THIS MANUAL

This manual explains how to install, operate, and maintain the Standard L and Builder Valve Maintenance Skid Systems. The manual describes four skid system configurations:

- Standard LX Diesel Skid System (77-000-54).
- Standard LX Gas Skid System (77-000-55).
- Standard Builder Diesel Skid Platform (77-000-60).
- Standard Builder Gas Skid Platform (77-000-61).

The manual includes instructions for set-up, operation, and maintenance. It also contains parts lists, diagrams, and service information to help you order replacement parts and perform user-serviceable repairs.

Before operating the VMS, you should read through this manual and become familiar with all instructions.

HOW TO USE THE MANUAL

This manual is organized to help you quickly find the information you need. Each chapter describes a specific topic on using or maintaining your equipment.

In This Chapter

PURPOSE OF THIS MANUAL

HOW TO USE THE MANUAL

SYMBOLS AND WARNINGS

MANUAL UPDATES AND
REVISION TRACKING

EQUIPMENT DESCRIPTION

Throughout this manual, refer to this column for warnings, cautions, and notices with supplementary information.

Each page is designed with two columns. This large column on the inside of the page contains instructions and illustrations. Use these instructions to operate and maintain the equipment.

The narrower column on the outside contains additional information such as warnings, special notes, and definitions. Refer to it for safety notes and other information.

SYMBOLS AND WARNINGS

The following symbols are used throughout this manual to indicate special notes and warnings. They appear in the outside column of the page, next to the section they refer to. Make sure you understand what each symbol means, and follow all instructions for cautions and warnings.



WARNING

A WARNING alert with the safety alert symbol indicates a potentially hazardous situation that **could** result in **serious injury or death**.



This is the **safety alert symbol**. It is used to alert you to **potential personal injury hazards**. Obey all safety messages that follow this symbol to avoid possible injury or death.



CAUTION

A CAUTION alert with the safety alert symbol indicates a potentially hazardous situation that **could** result in **minor or moderate injury**.



CAUTION

A CAUTION alert with the damage alert symbol indicates a situation that **will** result in **damage to the equipment**.



This is the **equipment damage alert symbol**. It is used to alert you to **potential equipment damage situations**. Obey all messages that follow this symbol to avoid damaging the equipment or workpiece on which it is operating.

NOTE

This symbol indicates a user note. Notes provide additional information to supplement the instructions, or tips for easier operation.



IMPORTANT

An IMPORTANT alert with the damage alert symbol indicates a situation that **may** result in **damage to the equipment**.



NOTE

A NOTE provides supplementary information or operating tips.

MANUAL UPDATES AND REVISION TRACKING

Occasionally, we will update manuals with improved operation or maintenance procedures, or with corrections if necessary. When a manual is revised, we will update the revision history on the title page.

You may have factory service or upgrades performed on the equipment. If this service changes any technical data or operation and maintenance procedures, we will include a revised manual when we return the equipment to you.

Current versions of E.H. Wachs Company manuals are also available in PDF format. You can request an electronic copy of this manual by emailing customer service at sales@ehwachs.com.

EQUIPMENT DESCRIPTION

E.H. Wachs sells a variety of skid-mounted valve maintenance systems (VMS) that the customer can install on their own vehicles. Systems are available with diesel or gas engines.

Two configurations are available with a standard set of valve maintenance equipment:

- Standard LX Diesel Skid System (77-000-54).
- Standard LX Gas Skid System (77-000-55).

Two configurations are available on a basic skid platform, with customer-selected equipment:

- Standard Builder Diesel Skid Platform (77-000-60).
- Standard Builder Gas Skid Platform (77-000-61).

The following sections describe the available configurations.

Standard LX Skid Systems

Standard LX Skid Systems are available with a 25 HP Kubota diesel engine (77-000-54), or a 27 HP Kohler gas engine (77-000-55).

These systems include the following features and standard equipment:

- Integrated hydraulic system with auxiliary HTMA class II circuit, 8 gpm @ 2,000 psi (30 l/m @ 138 bar).
- ERV-750 extended reach valve operator with telescoping valve key and ruggedized HC-100 controller/data logger.
- Vacuum system with 250 gallon (950 l) spoils tank, 3 suction wands, and hydraulic dump.
- 2.6 gpm (9.5 lpm), 3,000 psi (210 bar) pressure washer with 2 washer guns.
- 95 gallon (360 l) water tank and 3 gallon (11 l) anti-freeze tank.
- Service light bar with arrow board.
- 50' (15 m) auxiliary hydraulic hose reel.
- Vehicle storage tray for hydraulic breaker or other tools.

The following optional equipment is also available:

- TM-7 HD Plus valve operator.
- Job box (if not equipped with TM-7).
- Water heater.
- GNSS receiver for survey-grade GPS accuracy.

The following figures illustrate the components and features of the Standard LX systems.

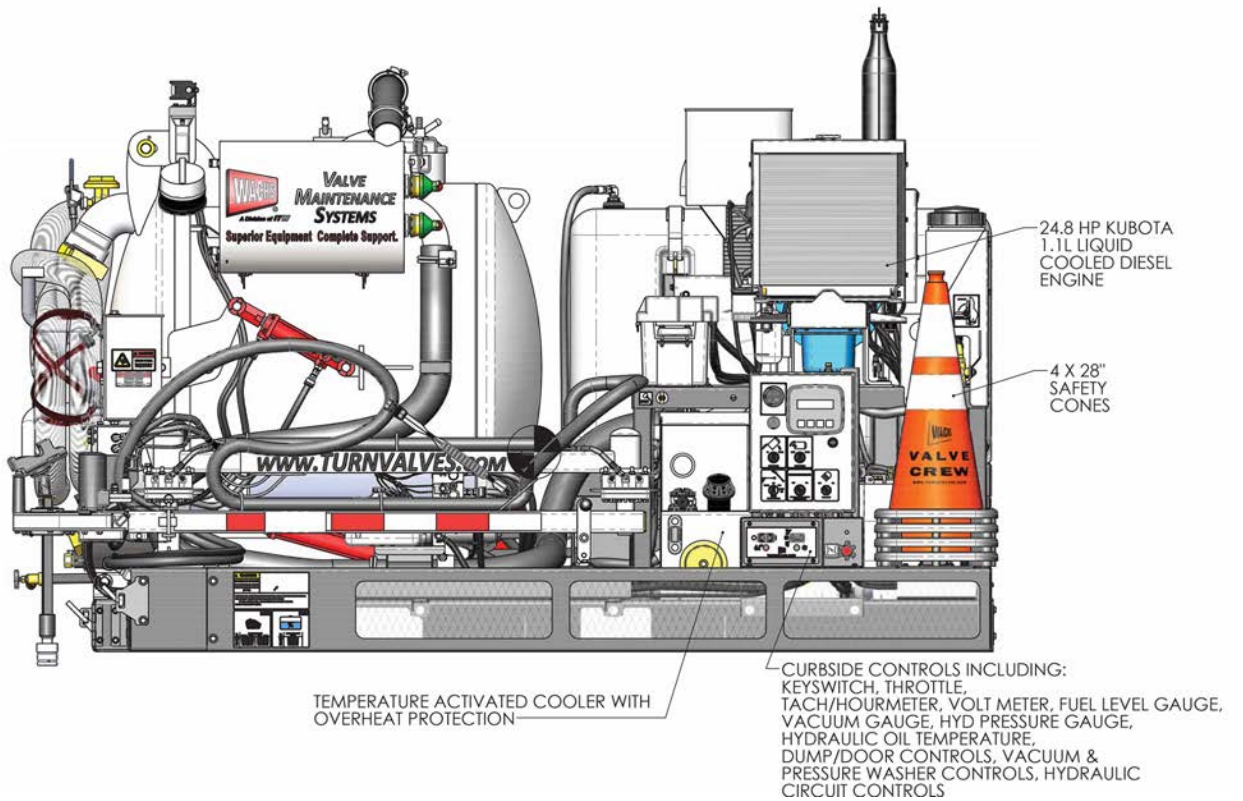

Figure 1-1. The drawing shows the controls-side view of the Standard LX diesel engine configuration, 77-000-54.

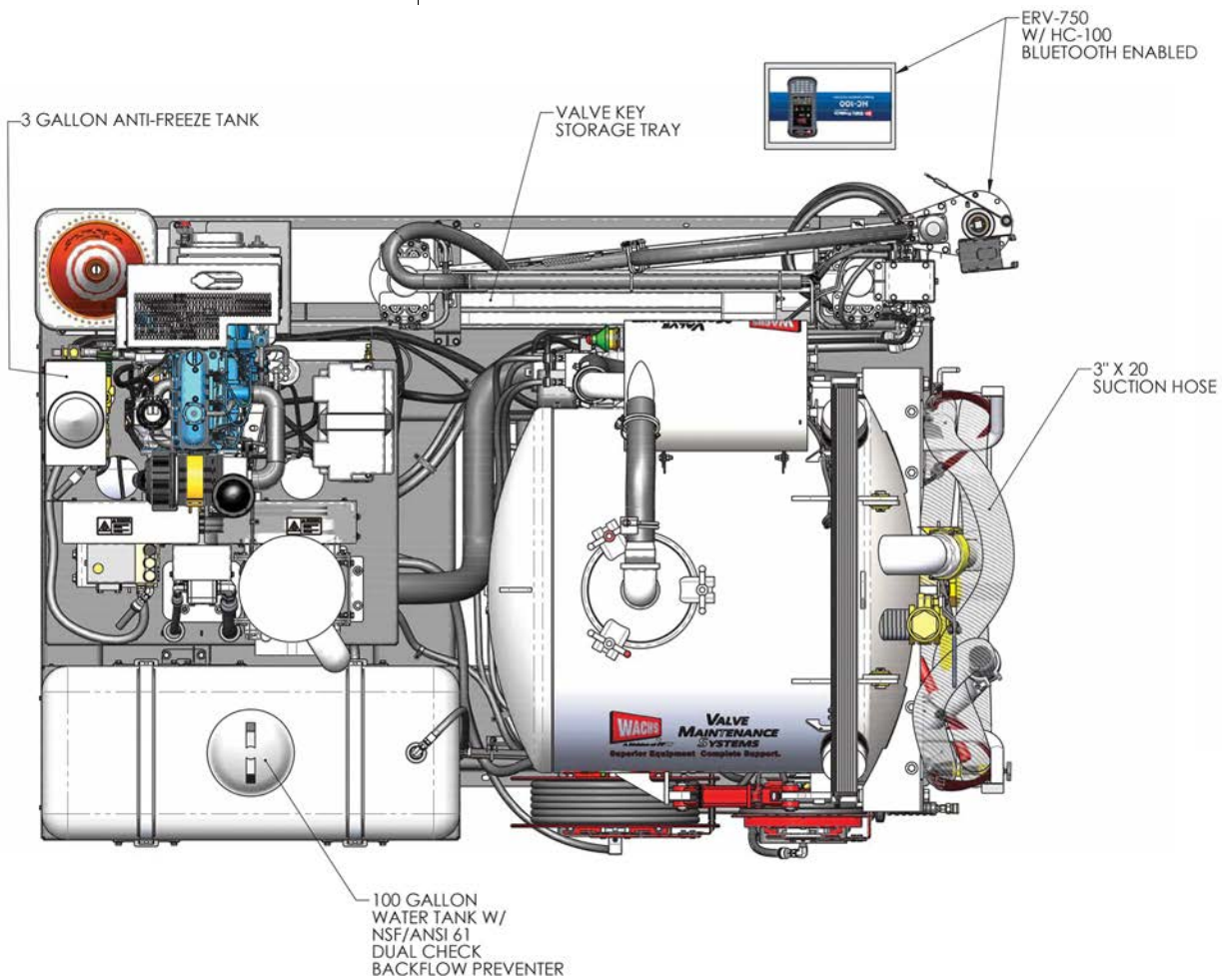

Figure 1-2. The drawing shows the top view of the Standard LX diesel engine configuration, 77-000-54.

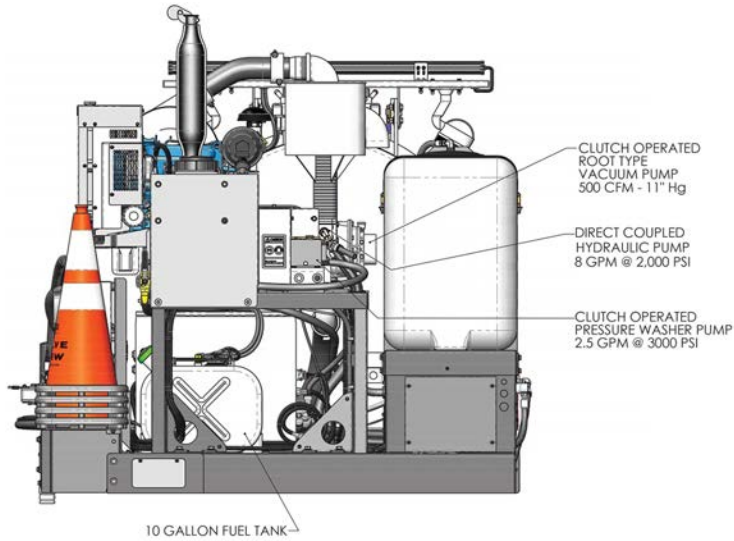

Figure 1-3. The drawing shows the front view of the Standard LX diesel engine configuration, 77-000-54.

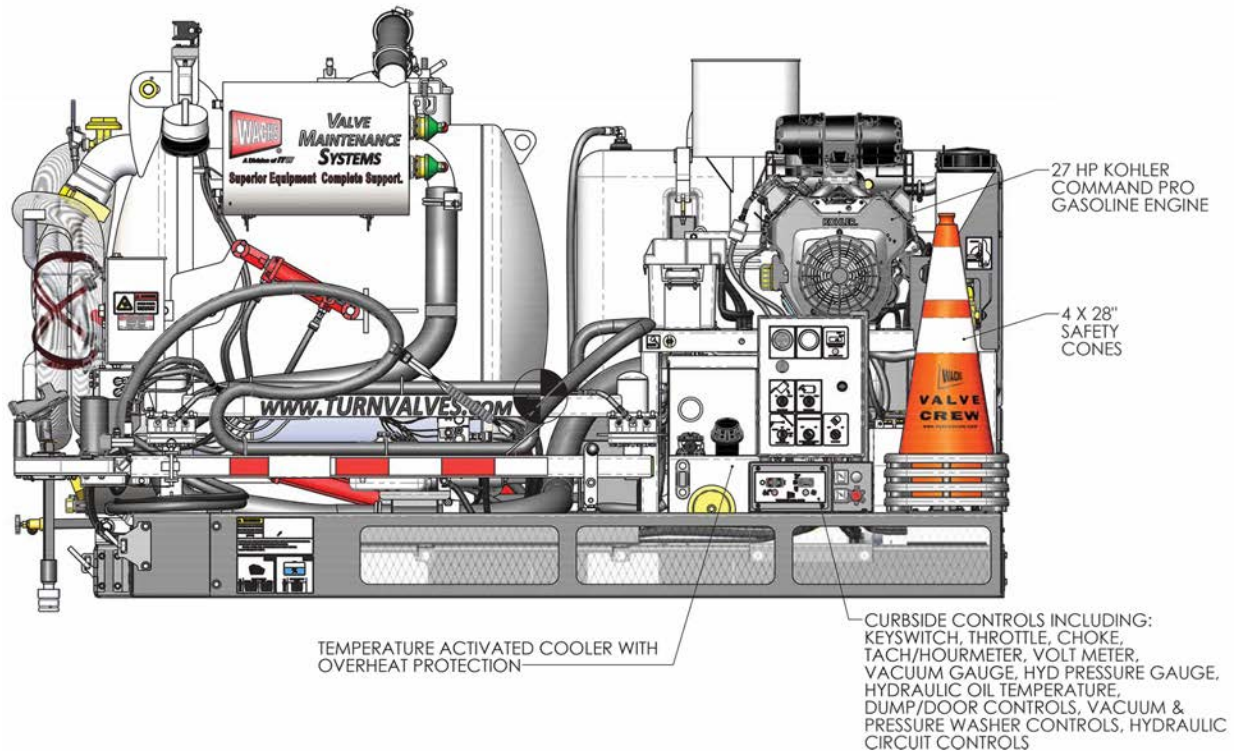

Figure 1-4. The drawing shows the controls-side view of the Standard LX gas engine configuration, 77-000-55.

Figure 1-5. The drawing shows the top view of the Standard LX gas engine configuration, 77-000-55.

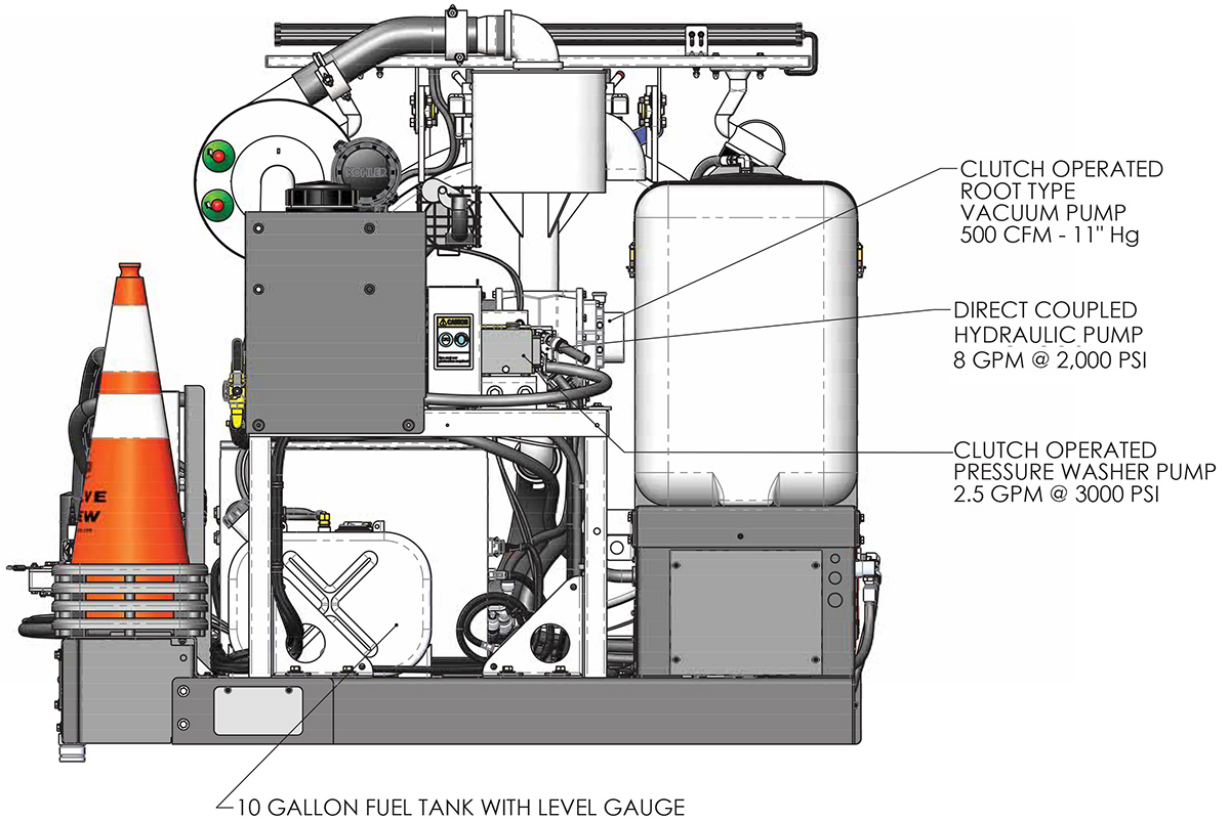

Figure 1-6. The drawing shows the front view of the Standard LX gas engine configuration, 77-000-55.

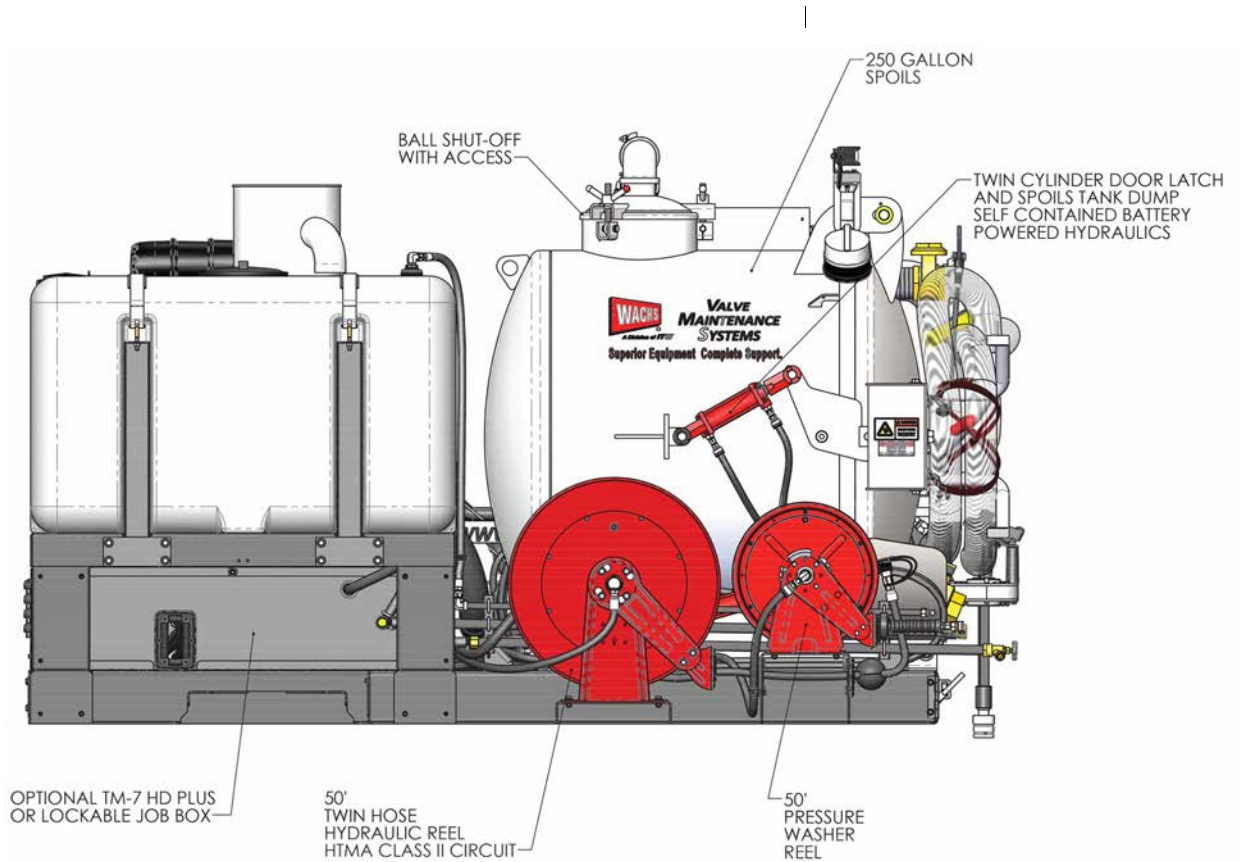

Figure 1-7. The drawing shows the tank-side view of the Standard LX (both diesel and gas configurations).

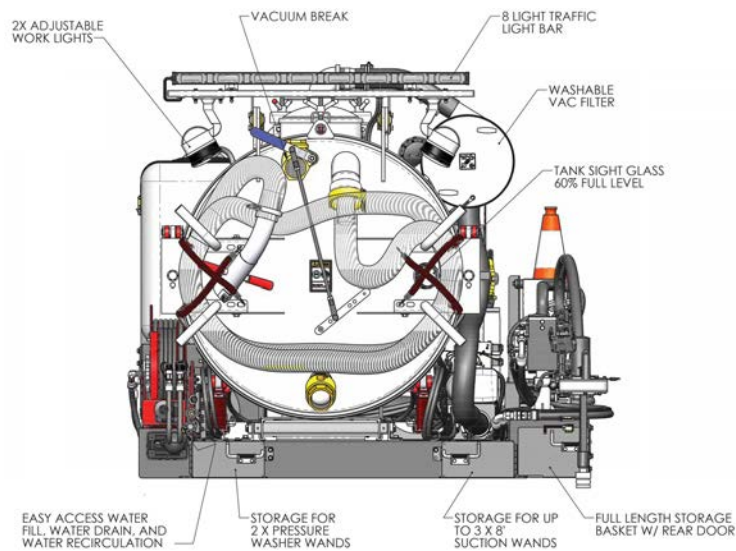

Figure 1-8. The drawing shows the rear view of the Standard LX (both diesel and gas configurations).

Standard Builder Skid Systems

Standard Builder Skid Systems are available with a 25 HP Kubota diesel engine (77-000-60), or a 27 HP Kohler gas engine (77-000-61).

Builder systems allow customers to select the valve maintenance equipment they need. The systems include the following basic components:

- Diesel or gas engine.
- Vacuum system with spoils tank (3 sizes available), 3 suction wands, and hydraulic dump.
- 2.6 gpm (9.5 lpm), 3,000 psi (210 bar) pressure washer with 2 washer guns.
- 95 gallon (360 l) water tank and 3 gallon (11 l) anti-freeze tank.
- Vehicle storage tray for hydraulic breaker or other tools.

The Builder Skid Systems can be outfitted with the following optional equipment and features when ordered:

- Integrated hydraulic system with auxiliary HTMA class II circuit, 8 gpm @ 2,000 psi (30 l/m @ 138 bar).
- ERV-750 extended reach valve operator with telescoping valve key and ruggedized HC-100 controller/data logger.
- Service light bar with arrow board.
- 50' (15 m) auxiliary hydraulic hose reel.
- TM-7 HD Plus valve operator.
- Water heater.
- GNSS receiver for survey-grade GPS accuracy.

The following figures illustrate the components and features of the Standard Builder systems. Labeling on the drawings indicate optional equipment.

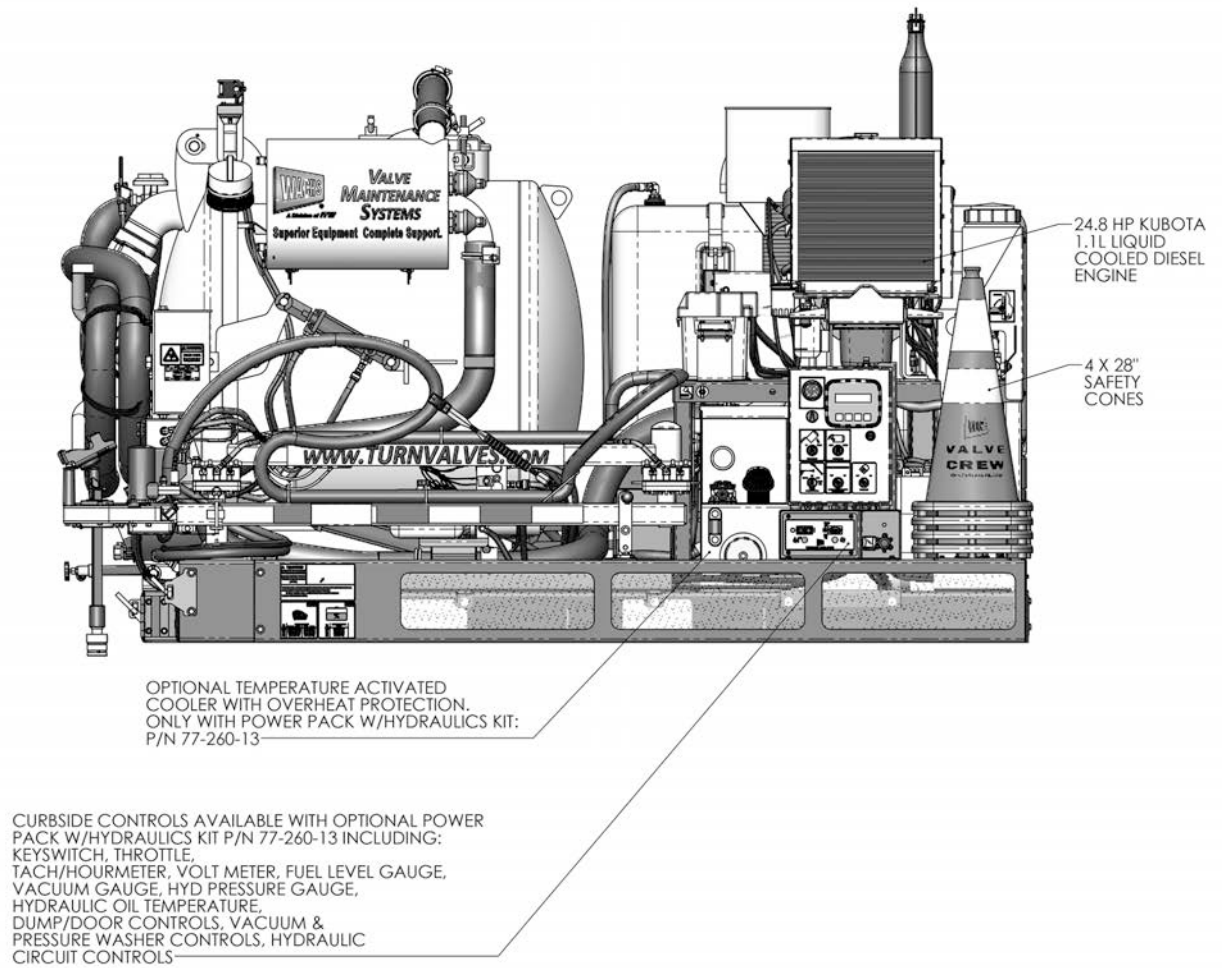

Figure 1-9. The drawing shows the controls-side view of the Standard Builder diesel engine configuration, 77-000-60.

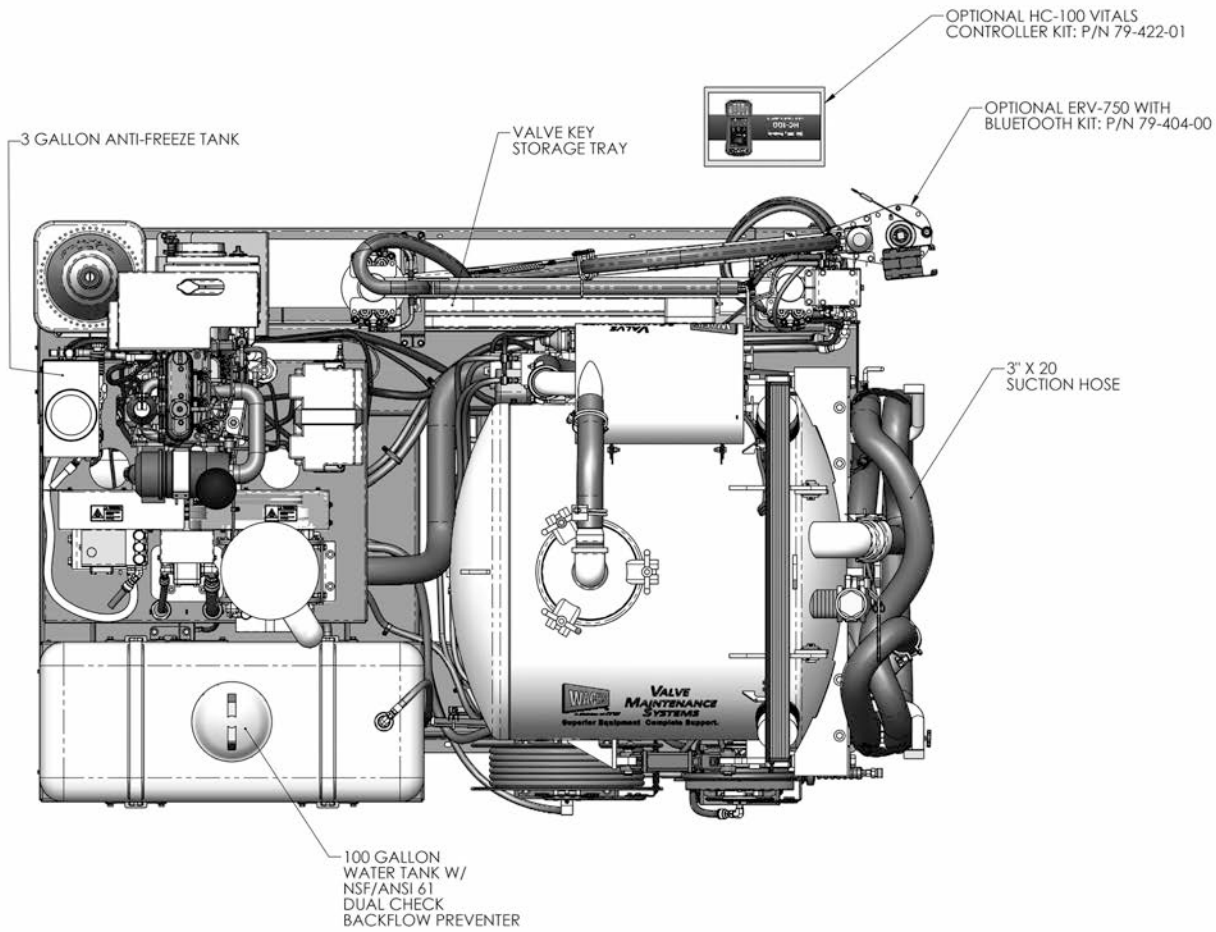

Figure 1-10. The drawing shows the top view of the Standard Builder diesel engine configuration, 77-000-60.

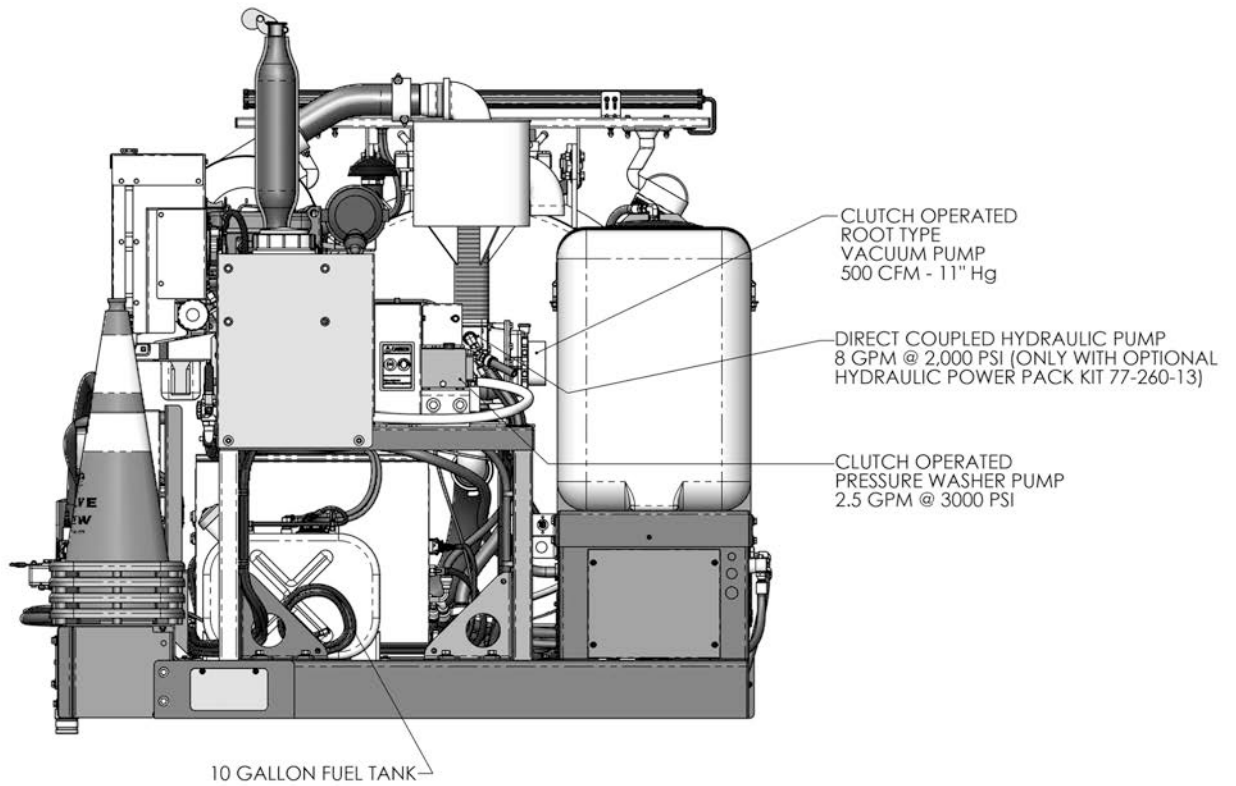
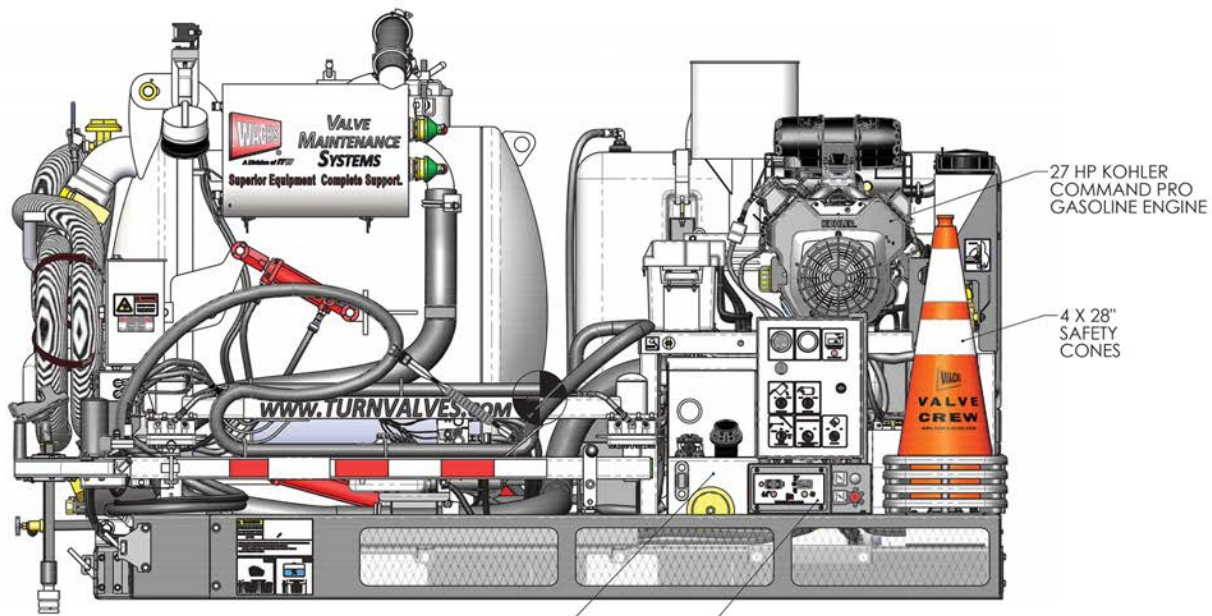

Figure 1-11. The drawing shows the front view of the Standard Builder diesel engine configuration, 77-000-60.



OPTIONAL TEMPERATURE ACTIVATED COOLER WITH OVERHEAT PROTECTION. ONLY WITH POWER PACK W/HYDRAULICS KIT: P/N 77-230-13

CURBSIDE CONTROLS AVAILABLE WITH OPTIONAL POWER PACK W/HYDRAULICS KIT P/N 77-230-13 INCLUDING: KEYSWITCH, THROTTLE, CHOKE, TACH/HOURMETER, VOLT METER, VACUUM GAUGE, HYD PRESSURE GAUGE, HYDRAULIC OIL TEMPERATURE, DUMP/DOOR CONTROLS, VACUUM & PRESSURE WASHER CONTROLS, HYDRAULIC CIRCUIT CONTROLS

Figure 1-12. The drawing shows the controls-side view of the Standard Builder gas engine configuration, 77-000-61.

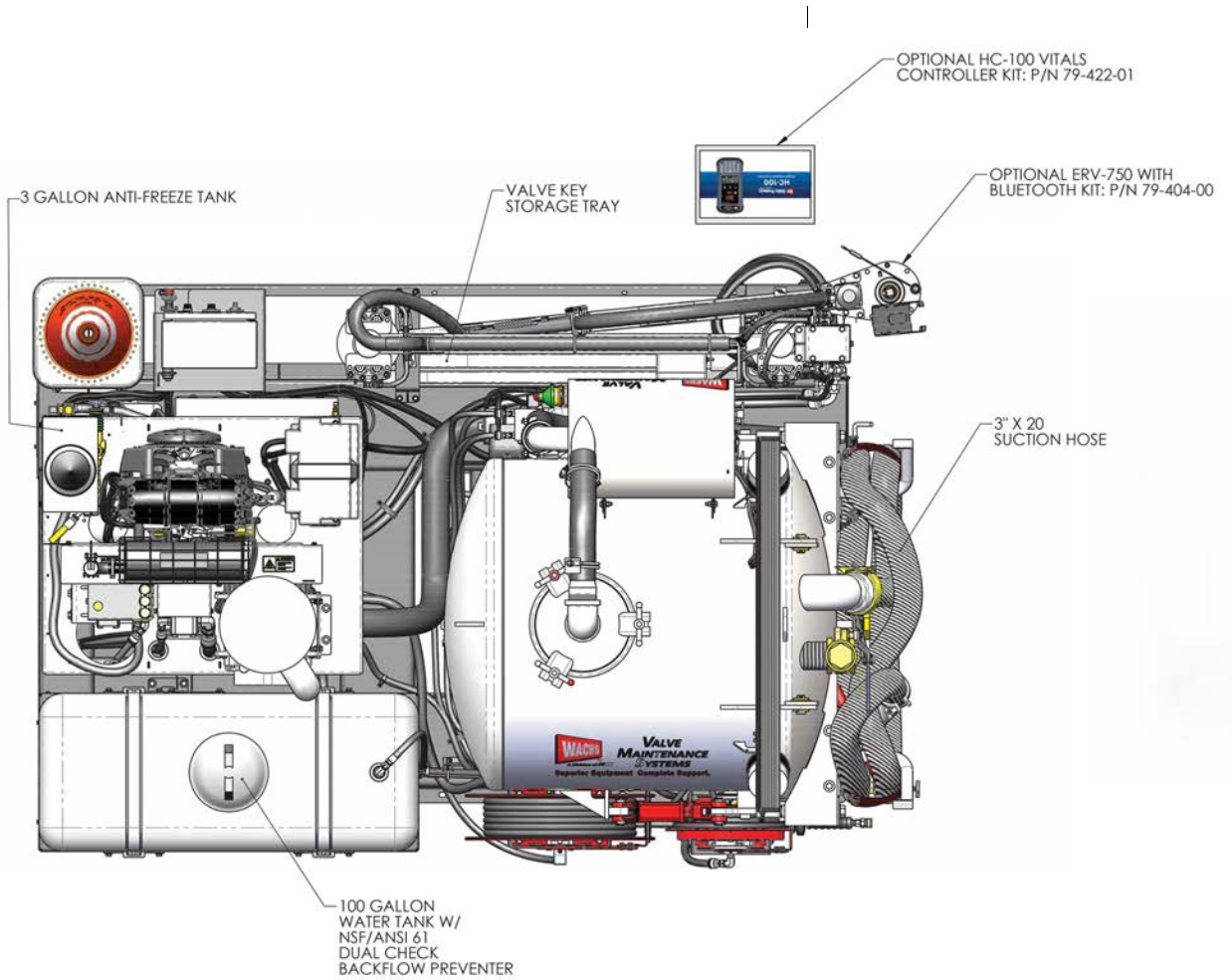

Figure 1-13. The drawing shows the top view of the Standard Builder gas engine configuration, 77-000-61.

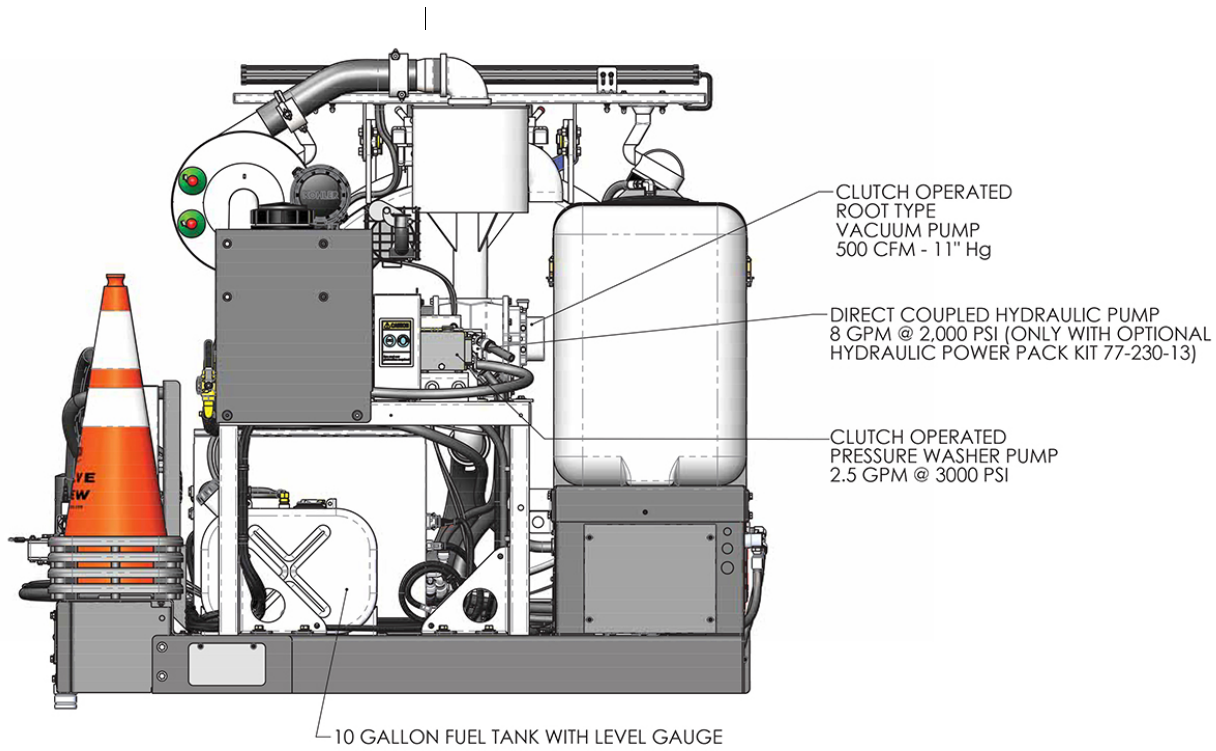

Figure 1-14. The drawing shows the front view of the Standard Builder gas engine configuration, 77-000-61.

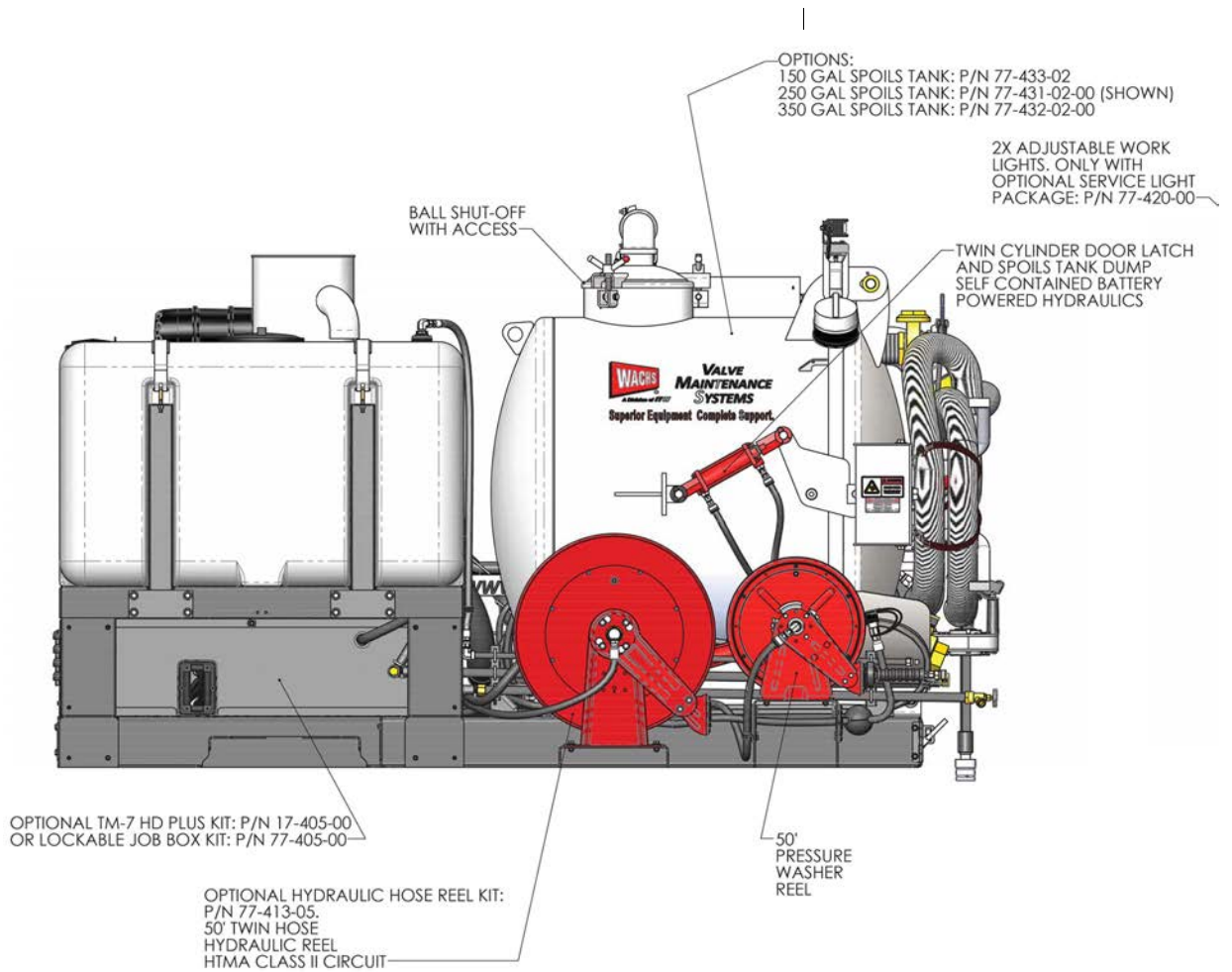

Figure 1-15. The drawing shows the tank-side view of the Standard Builder (both diesel and gas configurations).

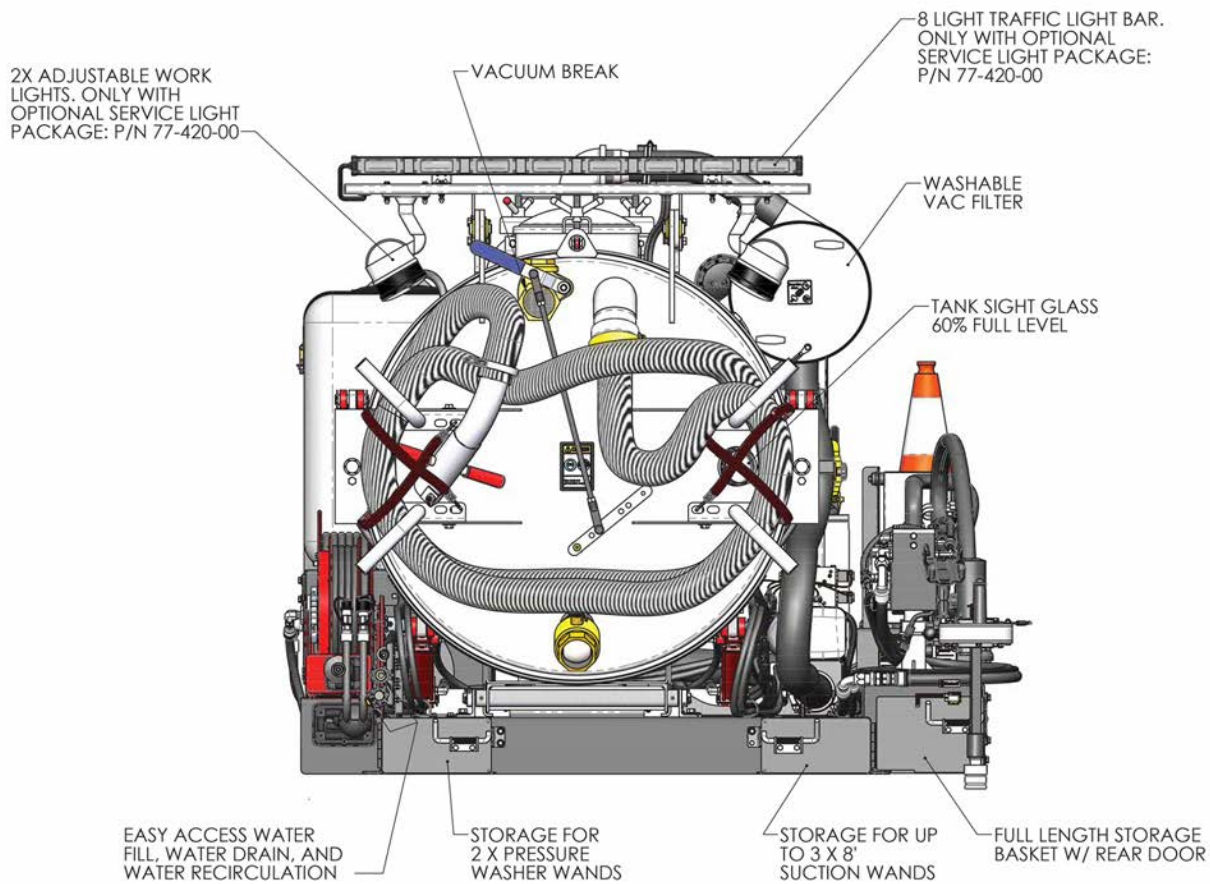

Figure 1-16. The drawing shows the rear view of the Standard Builder (both diesel and gas configurations).

Engine Specifications

The integrated engine operates all of the VMS equipment, including the hydraulic system and auxiliary circuit. Controls for starting and operating the engine are on the system curbside control panel.

The engine uses fuel from the vehicle fuel tank, supplied by an electric pump attached to the frame. The fuel system has two filters, one at the pump and one in the fuel line at the engine. The fuel pump is fused. See Chapter 4 for maintenance instructions on replacing the fuse and filters.

Diesel Engine (Configurations 77-000-54 and 77-000-60)

The diesel engine configurations use a 25 HP Kubota D1105-E4 Tier 4F engine.

The diesel engine is provided with an *Operator's Manual*. Refer to the Kubota manual for operating guidelines, maintenance, and service of the engine.

Gas Engine (Configuration 77-000-55 and 77-000-61)

The gas engine configuration uses a 27 HP Kohler Command Pro CH740 gasoline engine.

The engine operates on 87 octane unleaded gasoline or on 10% ethanol/90% gasoline “gasohol” blend. Use a winter blend fuel when running the engine in cold weather.

The Kohler engine is provided with an *Owner's Manual* and a *Service Manual*. Refer to the Kohler manuals for operating guidelines, maintenance, and service of the engine.

Hydraulic Power System

(Optional on Standard Builder systems.)

The system hydraulic pump is directly coupled to the engine. It provides 8 gpm (30 l/m) hydraulic flow at 2,000 psi (138 bar). The hydraulic system includes a 10 gallon (38 l) fluid reservoir, fan-cooled heat exchanger, and an auxiliary HTMA Class II circuit.

Use a high-quality hydraulic oil with anti-wear properties and a viscosity index of 140 minimum (per ASTM D2270). ISO-32 oil is recommended; it provides a good balance for hydraulic systems in freezing cold and hot summer conditions. For environments not subject to freezing conditions, you can substitute ISO-46 oil.

Vacuum System

The utility vacuum system includes a 500 CFM, 11” Hg positive displacement blower, tach/hourmeter, silencer, and washable filter. The vacuum includes a 200 gallon holding tank with a hydraulic dump door operated by an electronic control panel.

The following vacuum attachments are provided:

- A 3” diameter x 20 ft flexible suction hose, with connection elbow and handles for operation.
- 7/8” diameter x 8 ft vacuum wand.
- 1-1/4” diameter x 8 ft vacuum wand.
- 2-1/2” diameter x 8 ft vacuum wand.

All wands have a standard connector for the 3” suction hose elbow.

Pressure Washer

The clutch-driven pressure washer outputs 2.6 gpm @ 3000 psi. It includes the following features:

- 5 gallon priming tank
- 100 gallon water tank
- sprayer wand
- 50 ft hose on a spring-rewind hose reel.

Hydraulic Hose Reel

(Optional on Standard Builder systems.)

The hose reel supplies 50 ft of 1/2” hydraulic hose (rated 2000 psi) for operating auxiliary equipment. It includes hose whips and connectors to connect to the auxiliary tools.

ERV-750 Extended Reach Valve Operator

(Optional on Standard Builder systems.)

The ERV-750 is an extended-reach hydraulic valve operator on a telescoping arm mounted to a swivel base. It can reach valves up to 11 ft from the curb side of the truck, and provides up to 750 lb-ft of torque.



Figure 1-17. The ERV-750 valve operator extends on a telescoping swivel arm.

The ERV-750 includes the HC-100 handheld controller/data logger for operating the machine and collecting valve exercising data. The controller is available with optional GPS capability (either standard or submeter resolution) for automated valve locating and logging.

The HC-100 is available separately (79-422-01, North American version) if a spare or replacement is needed.

The ERV-750 is supplied with its own manual, *ERV-750 Extended Reach Valve Operator User's Manual*, for operating instructions and parts/service information.

TM-7 Automated Valve Exerciser (Optional)

The TM-7 HD Plus is a heavy-duty automated valve operator providing up to 2,500 lb-ft of torque. The power head is mounted on a rigid frame that slides out over the valve location and slides back onto the truck for storage.



Figure 1-18. The TM-7 is shown extended to its operating position.

The TM-7 HD Plus uses the HC-100 handheld control unit for operating the machine and collecting valve exercising data. The TM-7 operates in manual mode or in an exercising mode that automatically controls torque and direction to exercise valves safely and completely.

The TM-7 HD Plus is supplied with its own manual, *TM-7 Truck Mounted Valve Operator User's Manual*, for operating instructions and parts/service information.

Water Heater (Optional)

A water heater is available for heating sprayer water. When installed, the heater is integrated with the sprayer system, and water circulates through the heater. (You can bypass the heater, if desired, when not using it.)

The water heater operates on its own fuel source, with an attached fuel tank. **Use either kerosene or diesel fuel (#1 or #2). Do not use any other fuels.**

A separate manual is provided with the water heater: *Alkota Oil Water Heater Model 410 WH Operation & Service Manual*. Refer to this manual for detailed safety, service, and maintenance information.



WARNING

Do not use gasoline or any non-specified fuel in the water heater. Use of any other fuel could result in fire or explosion, causing serious injury or death.

DISMANTLING AND DISPOSAL

Hydraulics and Lubricants

- Whenever servicing or dismantling the equipment, always capture hydraulic fluid and lubricants. Recycle or dispose of fluids as required by local environmental law.
- Do not dispose of fluids by pouring down the drain.

Machinery and Components

- Recycle or dispose of metal and other equipment components as required by local environmental law.



SYSTEM COMPONENT MANUALS

The following separate manuals are provided for components of the VMS system. These manuals contain important safety, service, and maintenance information that may not be included in this manual.

- *Kubota Diesel Engine Operator's Manual* (for diesel engine configuration)
- *Kohler Command Pro Owner's Manual* (for gas engine configuration)
- *Roots Universal RAI, URAI-DSL, URAI-G & Metric Series Installation, Operation and Maintenance Manual*
- *ERV-750 Extended Reach Valve Operator User's Manual*
- *TM-7 Truck Mounted Valve Operator User's Manual* (optional)
- *Alkota Oil Water Heater Model 410 WH Operation & Service Manual* (optional).



Chapter 2

Safety

E.H. Wachs takes great pride in designing and manufacturing safe, high-quality products. We make user safety a top priority in the design of all our products.

Read this chapter carefully before operating the VMS. It contains important safety instructions and recommendations. Tool operators and maintenance personnel must always comply with the safety precautions in this manual, and on the stickers and tags attached to the equipment.

SAFE OPERATING GUIDELINES

Follow these guidelines for safe operation of all E.H. Wachs equipment.

- **READ THE OPERATING MANUAL.** Make sure you understand all setup and operating instructions before you begin. Keep this manual with the machine.
- **INSPECT MACHINE AND ACCESSORIES BEFORE USE.** Before starting the machine, look for loose bolts or nuts, leaking lubricant, rusted components, worn or damaged fittings, and any other physical conditions that may affect operation. Properly maintaining the machine can greatly decrease the chances for injury.
- **ALWAYS READ STICKERS AND LABELS.** Make sure all labels and stickers are in place, clearly legible, and in good condition. Refer to “Safety Labels” later in this chapter for label locations on the machine. Replace any dam-

In This Chapter

SAFE OPERATING GUIDELINES
SAFE OPERATION OF THE VMS



Look for this symbol throughout the manual. It indicates a personal injury hazard.

aged or missing safety labels; see Chapter 5 for ordering information.

- **ESTABLISH A TRAINING PROGRAM.** Ensure that all operators know how to operate the machinery safely. Do not operate the machinery unless you have been trained, or are under the supervision of an instructor.
- **KEEP CLEAR OF MOVING PARTS.** Keep hands, arms, and fingers clear of all rotating or moving parts. Always turn the machine off and disconnect the power source before doing any adjustments or service.
- **SECURE LOOSE CLOTHING AND JEWELRY.** Secure or remove loose-fitting clothing and jewelry, and securely bind long hair, to prevent them from getting caught in moving parts of the machine.
- **FOLLOW SAFE PROCEDURES FOR HANDLING LUBRICANTS.** Refer to the manufacturer's instructions and the Material Safety Data Sheets.

Safe Operating Environment



- Do not use this equipment in a potentially explosive atmosphere. Fire or explosion could result, with the risk of serious injury or death.
- Provide adequate lighting to use the equipment, in accordance with worksite or local regulations.
- **KEEP WORK AREA CLEAR.** Keep all clutter and nonessential materials out of the work area. Only people directly involved with the work being performed should have access to the area.
- The end user is responsible for providing a safe hydraulic hose management procedure for the worksite. This should take into account mechanical protection of the hoses and trip hazards presented by the hoses. It is strongly recommended that the end user conduct a risk assessment to identify these risks and specify a suitable control action for hose management.
- Start in a work area without bystanders. The operator must be familiar with all prohibited work areas in the environment, and all worksite safety guidelines and procedures.

Safety Alerts in This Manual

The following alerts are used throughout this manual to indicate operator safety hazards. In all cases, these alerts include a notice describing the hazard and the means to avoid or reduce risk. Carefully read all safety alerts.



This icon is displayed with any safety alert that indicates a personal injury hazard.

WARNING

This safety alert, with the personal injury hazard symbol, indicates a potentially hazardous situation that, if not avoided, **could** result in **death or serious injury**.

CAUTION

This safety alert, with the personal injury hazard symbol, indicates a potentially hazardous situation that, if not avoided, **could** result in **minor or moderate injury**.

Protective Equipment Requirements

Protective Clothing

Wear safety shoes when operating or servicing the equipment. Serious injury could result from dropping the machine or its components.

Do not wear gloves while operating the valve operator(s). Gloves are an entanglement hazard with moving parts.



NOTE

Gloves can be worn to protect hands from the weather and hot machine surfaces. However, **do not wear gloves while operating the valve operator(s).**

Eye Protection



The Eye Protection hazard label is affixed to the machine. Always wear impact-resistant eye protection while operating or working near this equipment.

Hearing Protection



The Hearing Protection hazard label is affixed to the machine. The highest continuous noise levels recorded for this equipment exceed 80 dB(A). Equipment operators/maintainers must wear hearing protection.

SAFE OPERATION OF THE VMS

Proper Use of the VMS

- This equipment is to be operated, serviced, and maintained only by qualified, trained personnel.
- Make sure the vehicle is stable and level when parked at the work location.
- Keep personnel away from the rear of the truck when dumping the spoils tank.
- Dump the spoils tank only in authorized dumping areas.
- DO NOT wear gloves when operating the valve operator(s). Gloves can become entangled in rotating machinery, causing serious injury. (You can wear gloves when performing other tasks with the VMS machinery.)
- Before performing any service on the equipment, disconnect the power source(s). Follow all lock-out/tag-out procedures required at the worksite.

Hydraulic Powered Equipment

- Be sure all hoses are connected for correct flow to and from the equipment you are operating.
- Hydraulic components such as hoses, motors, and manifolds will get hot during operation and may cause burns. Do not touch hydraulic components, except for operator controls, during or after operating the machine.



WARNING

Exceeding the maximum hydraulic pressure or flow rate can result in equipment damage or operator harm.

- **Hydraulic injection injury**—A pinhole in a hydraulic hose or fitting can eject fluid with enough force to pierce skin. Check hoses and fittings regularly for leaks. **Do not use bare hands to check for leaks while the system is pressurized.** If you suspect a leak, move a piece of paper or cardboard at least 6 inches (15 cm) over the suspicious area and watch for fluid spraying on the surface.

Misuse of Equipment

- Do not use the machinery for any purpose other than the procedures described in this manual.
- Do not use the machinery in a potentially explosive environment.
- Do not operate the machinery without all covers in place.
- Do not climb or step on the machinery.
- Do not perform any set-up, maintenance, adjustments, service, or disassembly of the machinery without first disconnecting power sources and performing any site-required lock-out tag-out (LOTO) procedure.

Potential Hazards

Hot Surfaces. Hydraulic components become hot during operation. Do not touch any surface before making sure it is not hot enough to cause burns.

Noise Hazard. The highest continuous noise levels recorded for this equipment exceed 80 dB(A). Equipment operators/maintainers must wear hearing protection.

Flying Debris. The VMS pressure washer can create airborne debris during operation. Auxiliary tools connected to the hydraulic system may also create debris. Always wear impact-resistant eye protection while operating or working near this equipment.



WARNING

Injection of hydraulic fluid through the skin is a serious injury that can result in infection, tissue damage, and possible loss of limb. **Seek medical treatment immediately.** First aid is not sufficient treatment for injection injury.





High-Pressure Hydraulic Fluid. A pinhole in a hydraulic hose or fitting can eject fluid with enough force to pierce skin. Check hoses and fittings regularly for leaks. **Do not use bare hands to check for leaks while the system is pressurized.**

Outdoor Use. The VMS is designed for outdoor use. Do not operate the machine outdoors during or immediately after (30 minutes) an electrical storm

Residual Risks

- Hot surfaces on hydraulic components after operation.
- Noise hazard during operation of the machine.
- Entanglement hazards from moving parts of the machine.
- Handling of potentially hazardous materials, including fluids and lubricants used for operation and maintenance of the machine.
- Trip hazards from cords and hydraulic hoses.
- Slip and fall hazards from spilled hydraulic fluid or lubricants.

Disconnecting Power

Power is disconnected by turning off the engine and turning off the power inverter.

Before performing any service or storing the VMS, make sure to release any residual hydraulic pressure and water pressure.

Chapter 3

Installation

INSTALLATION OVERVIEW

The system overview drawings in Chapter 6 include skid and equipment dimensions, vehicle requirements, and installation notes. See **Sheet 1** of the overview drawing for your system configuration:

- 77-000-54, Standard LX Diesel
- 77-000-55, Standard LX Gas
- 77-000-60, Standard Builder Diesel
- 77-000-61, Standard Builder Gas.

This chapter includes data required for performing installation of the skid on your vehicle.

NOTE: The customer and upfitter are responsible for not outfitting the vehicle above its gross vehicle weight rating (GVWR).

- **All passengers, equipment, fuel, vacuum spoils, water, and cargo must be accounted for.**
- **The upfitter shall supply a label with GVWR and completed vehicle weight placed on the driver's door jamb.**
- **The customer shall not load the vehicle above its GVWR.**
- **Spoils and water weight for the supplied VMS configuration are provided on the VMS. See Sheet 6 of your system's layout drawing (in Chapter 6) for label information and placement.**

In This Chapter

INSTALLATION OVERVIEW

STANDARD LX DIESEL (77-000-54)

STANDARD LX GAS (77-000-55)

STANDARD BUILDER DIESEL (77-000-60)

STANDARD BUILDER GAS (77-000-61)



IMPORTANT

The upfitter is responsible for the completed vehicle. This includes mounting the skid to a vehicle frame suitable for the loaded weight of the skid, using the mounting holes provided.



IMPORTANT

If the optional TM-7 is installed, additional mounting holes are required. See drawing no. 17-405-00 in Chapter 6 for TM-7 installation details.

Figure 1 illustrates the mounting hole configuration and dimensions for all VMS skids. See the section of this chapter for your VMS configuration for weights and specifications.

The skid must be mounted to a frame suitable to handle the weight of the skid with full spoils and full water.

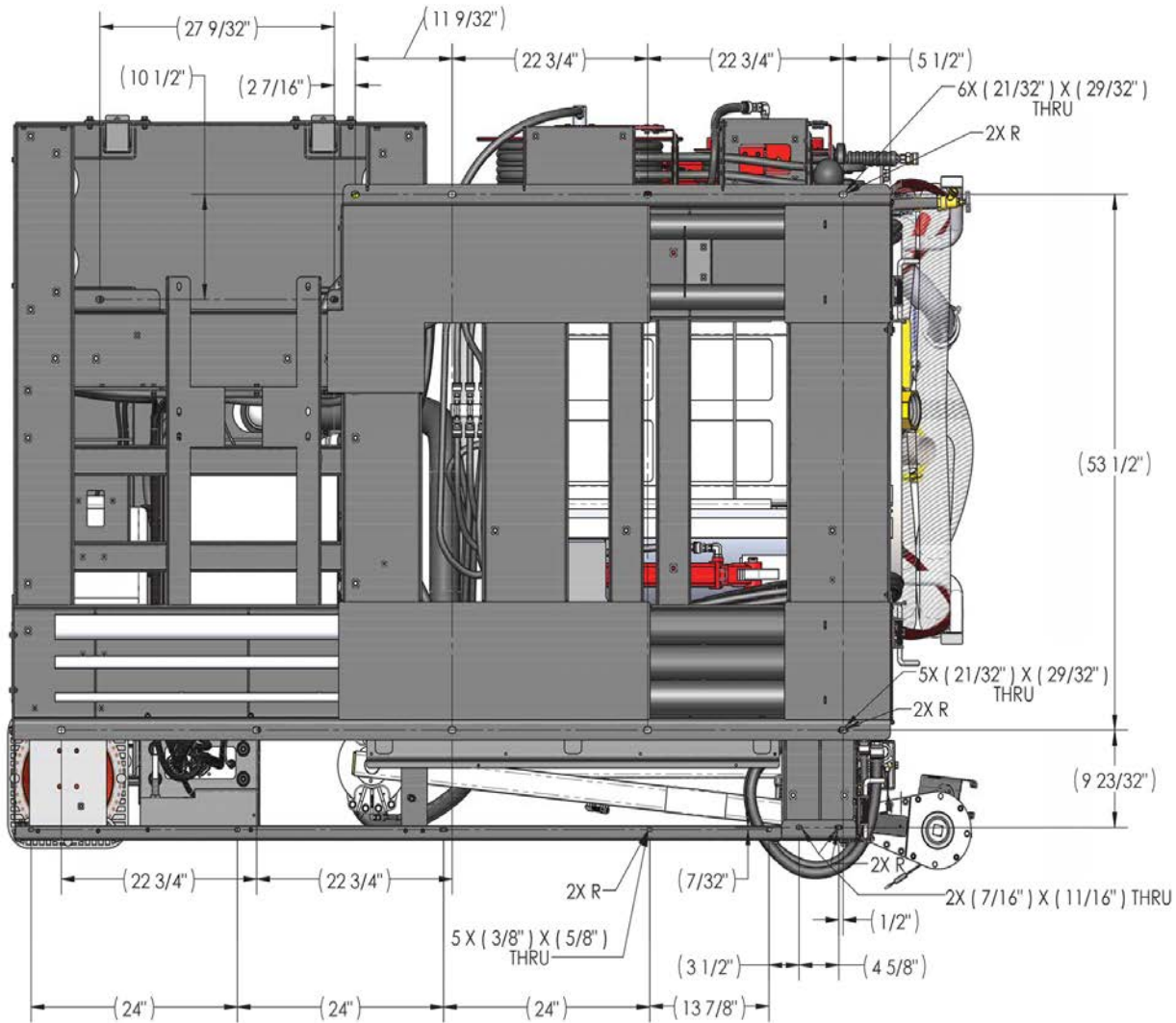

MOUNTING HOLES
 11X 1/2" GRADE 8 BOLTS &
 7X 5/16" BOLTS UPFITTER SUPPLIED.
 REQUIRED FOR MOUNTING.

Figure 3-1. The diagram shows the mounting hole locations for installing the skid on the vehicle (all VMS configurations).

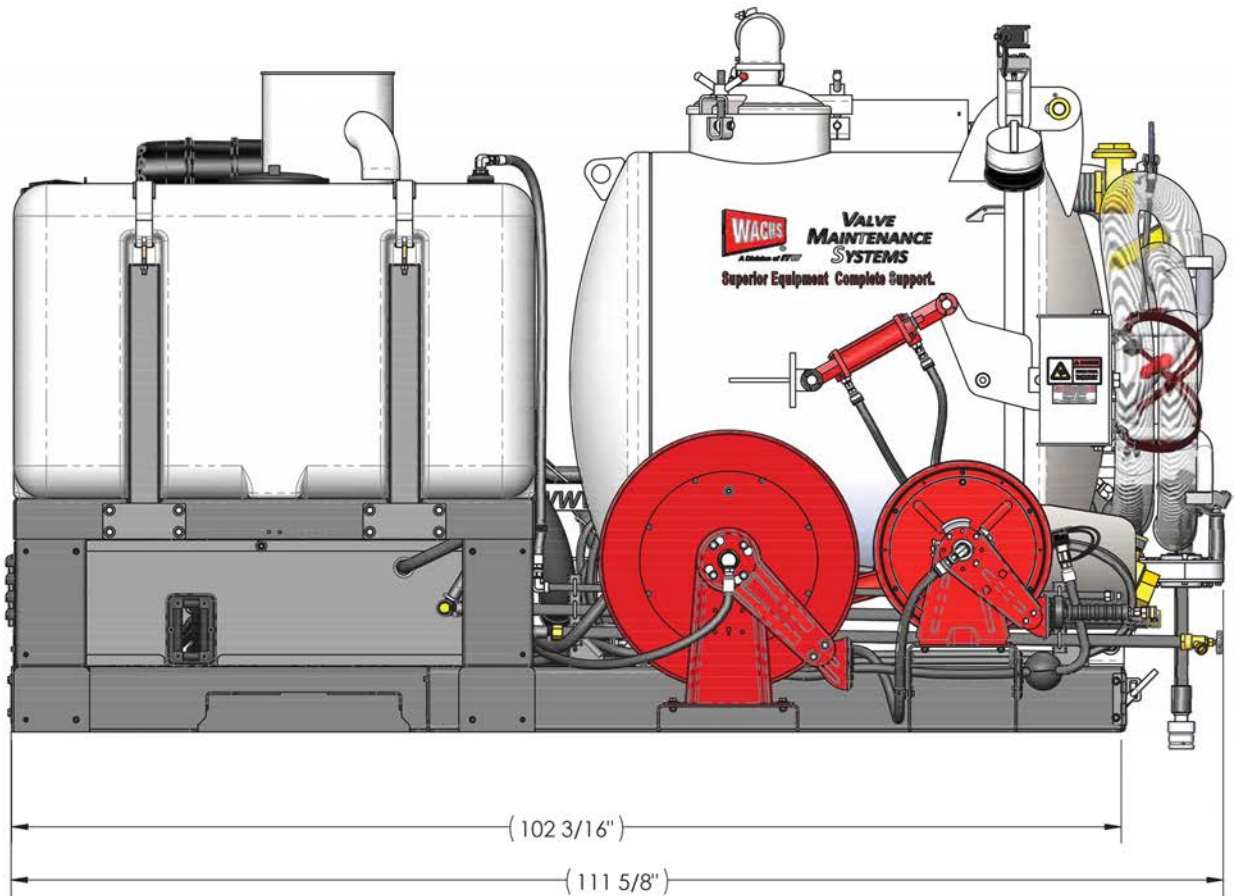

Figure 3-2. The drawing shows length dimensions for the skid systems (all configurations, with options).

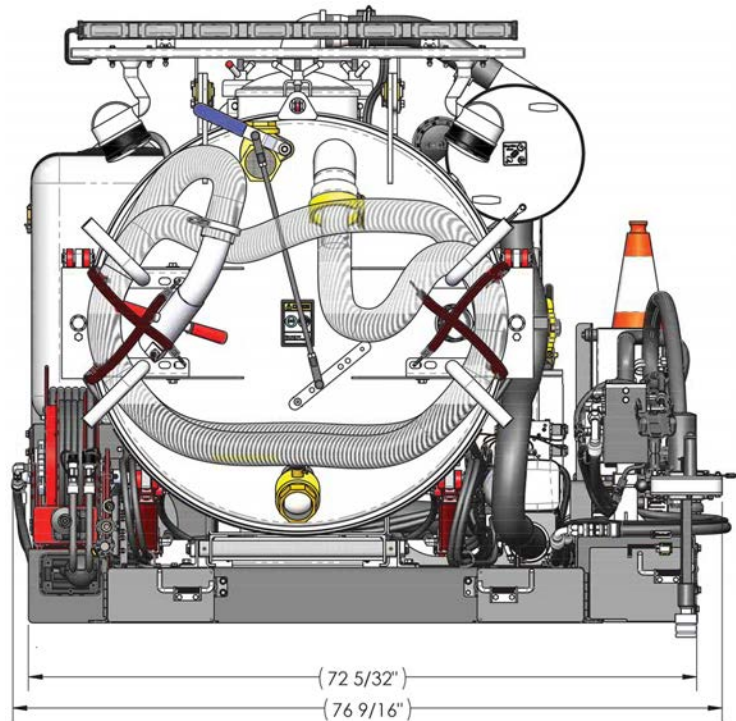

Figure 3-3. The drawing shows width dimensions for the skid systems (all configurations, with options).

Schematics

Schematics are provided in the overview drawing sets in Chapter 6 for each system configuration:

- Electric schematics are on sheets 13-14 of each overview drawing set.
- Hydraulic schematics are on sheet 15 of each overview drawing set.
- Pressure washer system schematics are on sheet 16 of each overview drawing set.

STANDARD LX DIESEL (77-000-54)

The following drawing and table illustrate weight and center of gravity specifications for the Standard LX Diesel skid system.

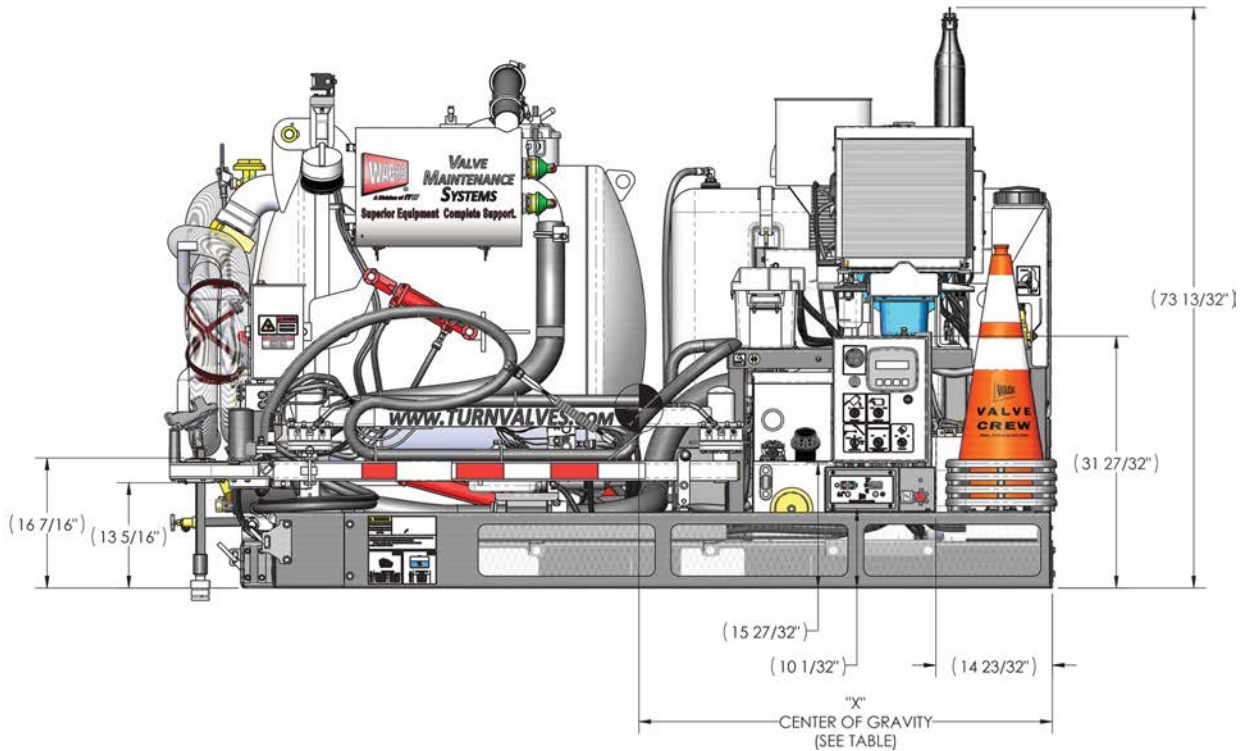

Figure 3-4. Dimensions and center of gravity specifications for Standard LX Diesel skid system.

WEIGHT AND CENTER OF GRAVITY TABLE			
250 GAL SPOILS TANK	100 GAL WATER TANK	"X" (INCHES), APPROX	WEIGHT APPROX, (LBS)
EMPTY	EMPTY	51 5/8"	4194
EMPTY	FULL (WATER)	47"	5028
FULL (WATER)	EMPTY	59 3/4"	6182
FULL (WATER)	FULL (WATER)	55 3/8"	7026
HYDRAULIC RESERVOIR FULL, FUEL TANK FULL, ANTI-FREEZE TANK FULL			

Figure 3-5. Weight and center of gravity specifications for Standard LX Diesel skid system.



IMPORTANT

The weight table assumes water as the tank spoils material. Aggregate or wet sand add significant weight. Adjust GVWR for expected maximum spoils weight.

STANDARD LX GAS (77-000-55)

The following drawing and table illustrate weight and center of gravity specifications for the Standard LX Gas skid system.

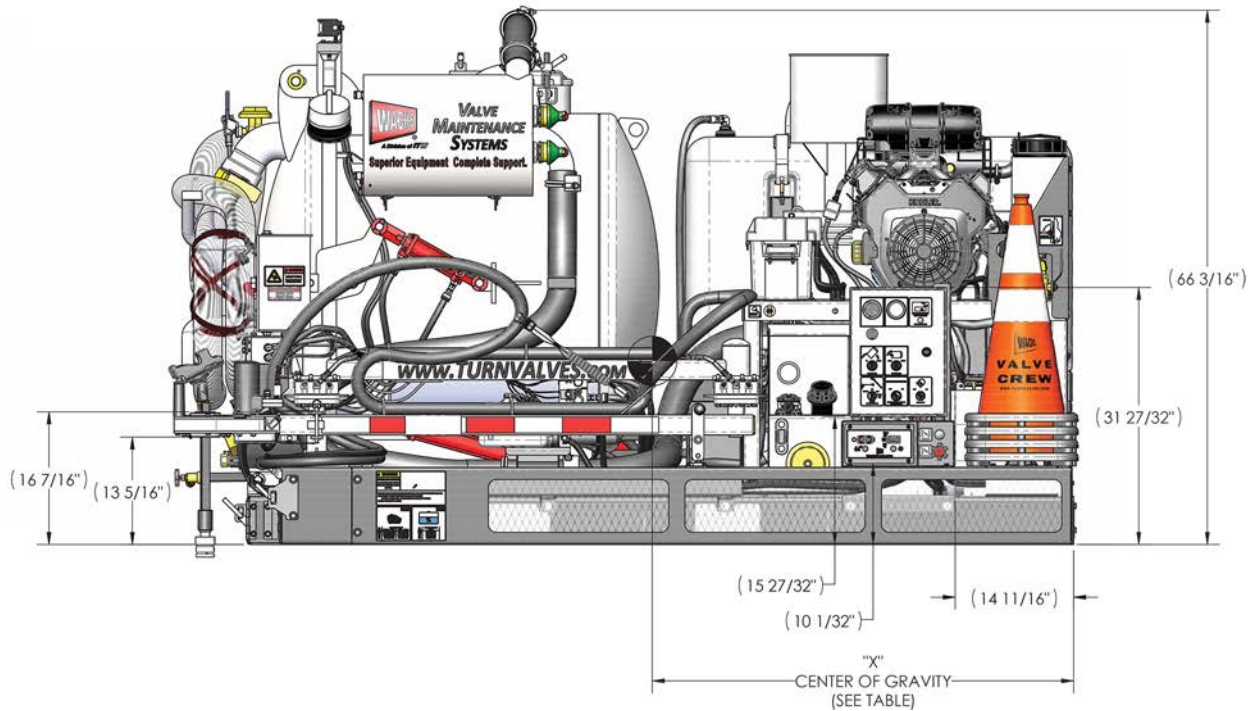

Figure 3-6. Dimensions and center of gravity specifications for Standard LX Gas skid system.



IMPORTANT

The weight table assumes water as the tank spoils material. Aggregate or wet sand add significant weight. Adjust GVWR for expected maximum spoils weight.

WEIGHT AND CENTER OF GRAVITY TABLE			
250 GAL SPOILS TANK	100 GAL WATER TANK	"X" (INCHES), APPROX	WEIGHT APPROX, (LBS)
EMPTY	EMPTY	54"	3902
EMPTY	FULL (WATER)	48 5/8"	4736
FULL (WATER)	EMPTY	61 3/4"	5890
FULL (WATER)	FULL (WATER)	57"	6725
HYDRAULIC RESERVOIR FULL, FUEL TANK FULL, ANTI-FREEZE TANK FULL			

Figure 3-7. Weight and center of gravity specifications for Standard LX Gas skid system.

STANDARD BUILDER DIESEL (77-000-60)

The following drawing and tables illustrate weight and center of gravity specifications for the Standard Builder Diesel skid system.

The drawing and data include the optional equipment:

- ERV-750 with Bluetooth kit
- 250 gallon spoils tank
- Diesel power pack kit
- Service light package
- Hydraulic hose reel kit.

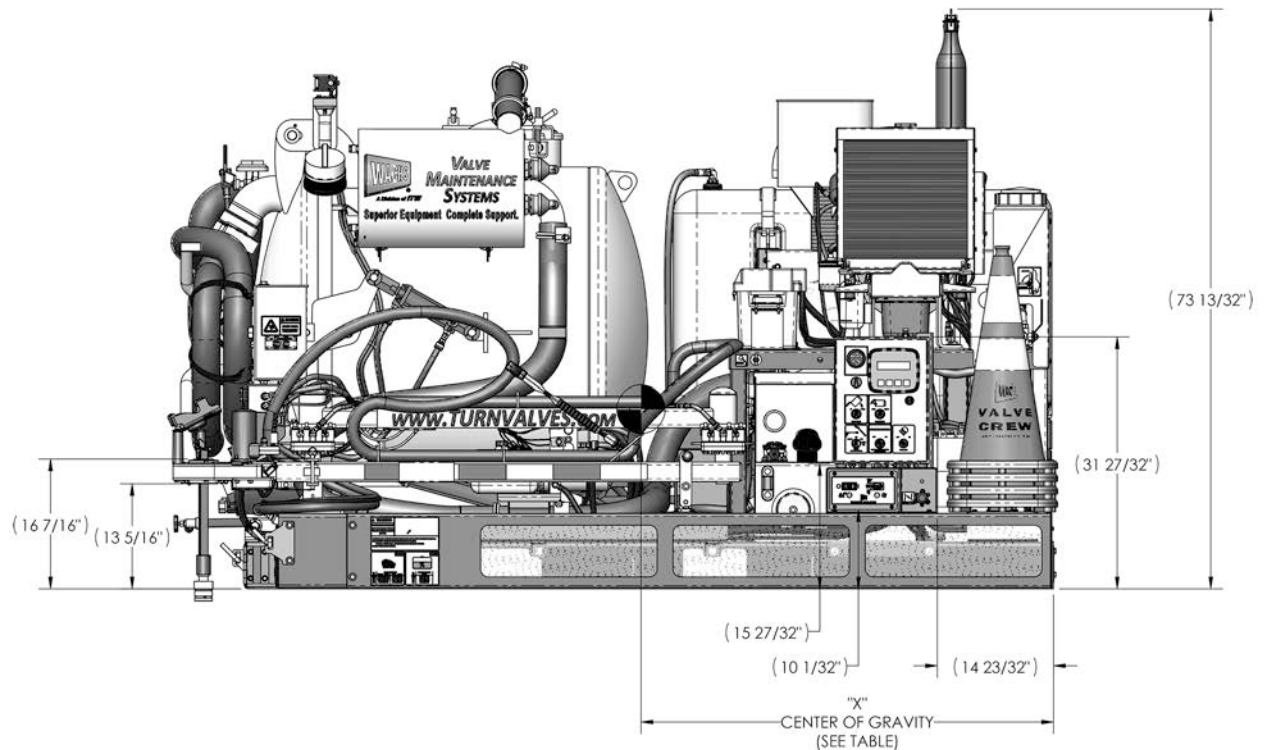

Figure 3-8. Dimensions and center of gravity specifications for Standard Builder Diesel skid system.



IMPORTANT

The weight tables assume water as the tank spoils material. Aggregate or wet sand add significant weight. Adjust GVWR for expected maximum spoils weight.

WEIGHT AND CENTER OF GRAVITY TABLE FOR MIN WEIGHT CONFIGURATION. INSTALLED: POWER PACK KIT WITH NO HYDRAULICS P/N: 77-260-12, 150 GALLONS SPOILS TANK P/N: 77-433-02. NO VALVE MACHINE OPTIONS, LX FEATURES OR HOT WATER HEATER INSTALLED.			
150 GAL SPOILS TANK	100 GAL WATER TANK	"X" (INCHES), APPROX	WEIGHT APPROX. (LBS)
EMPTY	EMPTY	51"	3462
EMPTY	FULL (WATER)	45 3/4"	4296
FULL (WATER)	EMPTY	60 1/2"	4912
FULL (WATER)	FULL (WATER)	55 1/8"	5747
HYDRAULIC RESERVOIR ON HPU FULL, FUEL TANK FULL, ANTI-FREEZE TANK FULL			

WEIGHT AND CENTER OF GRAVITY TABLE FOR MAX WEIGHT CONFIGURATION. INSTALLED: POWER PACK KIT WITH HYDRAULICS P/N: 77-260-13, 350 GALLONS SPOILS TANK P/N: 77-432-02-00, ERV-750 KIT P/N: 79-404-00, TM-7 HD PLUS KIT P/N: 17-405-00, HC-100 VITALS CONTROLLER KIT P/N: 79-422-01, LIGHT BAR KIT P/N: 77-420-00, HYDRAULIC HOSE REEL KIT P/N: 77-413-05. HOT WATER HEATER NOT INSTALLED.			
350 GAL SPOILS TANK	100 GAL WATER TANK	"X" (INCHES), APPROX	WEIGHT APPROX. (LBS)
EMPTY	EMPTY	51 7/8"	4538
EMPTY	FULL (WATER)	48 1/8"	5373
FULL (WATER)	EMPTY	60 7/8"	7064
FULL (WATER)	FULL (WATER)	57 3/8"	7900
HYDRAULIC RESERVOIRS FULL, FUEL TANK FULL, ANTI-FREEZE TANK FULL			

Figure 3-9. Weight and center of gravity specifications for Standard Builder Diesel skid system.
NOTE: See table in Section 77-000-54 for 250 gallon spoils tank weight and center of gravity.

STANDARD BUILDER GAS (77-000-61)

The following drawing and tables illustrate weight and center of gravity specifications for the Standard Builder Gas skid system.

The drawing and data include the optional equipment:

- ERV-750 with Bluetooth kit
- 250 gallon spoils tank
- Gas power pack kit
- Service light package
- Hydraulic hose reel kit.

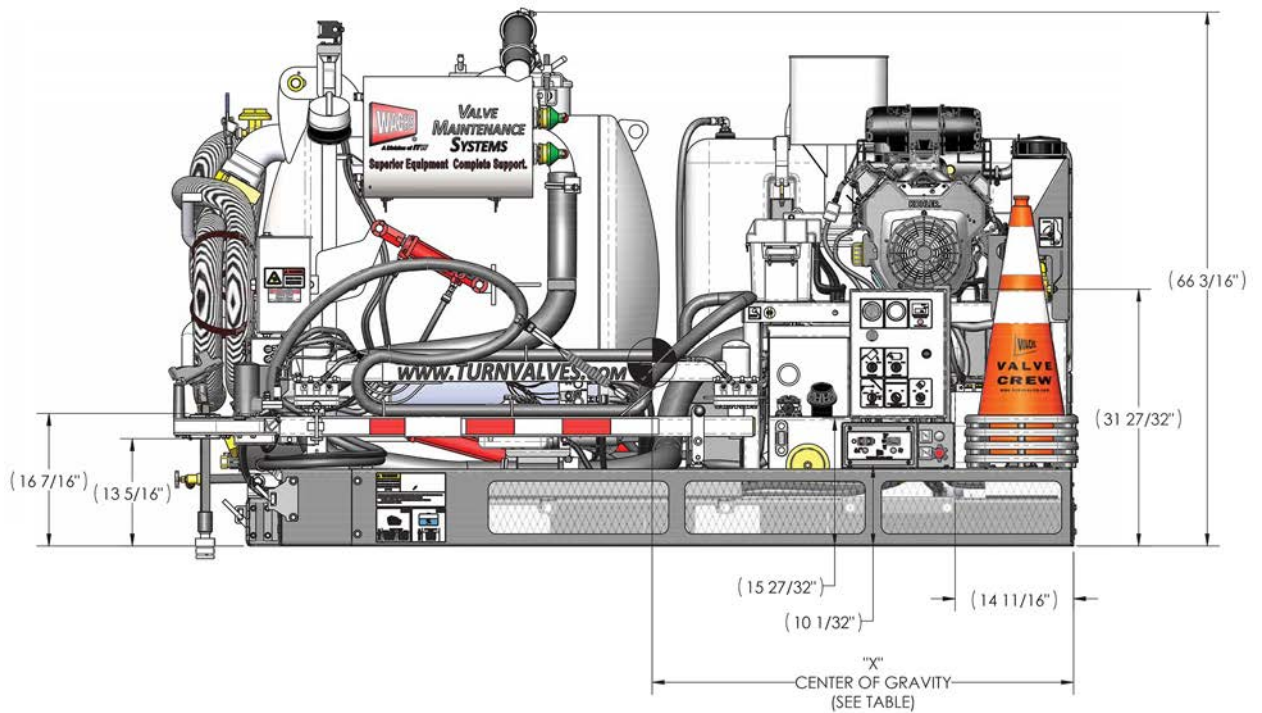

Figure 3-10. Dimensions and center of gravity specifications for Standard Builder Gas skid system.



IMPORTANT

The weight tables assume water as the tank spoils material. Aggregate or wet sand add significant weight. Adjust GVWR for expected maximum spoils weight.

WEIGHT AND CENTER OF GRAVITY TABLE FOR MIN WEIGHT CONFIGURATION. INSTALLED: POWER PACK KIT WITH NO HYDRAULICS P/N: 77-230-12, 150 GALLONS SPOILS TANK P/N: 77-433-02. NO VALVE MACHINE OPTIONS, LX FEATURES OR HOT WATER HEATER INSTALLED.			
150 GAL SPOILS TANK	100 GAL WATER TANK	"X" (INCHES), APPROX	WEIGHT APPROX. (LBS)
EMPTY	EMPTY	54"	3160
EMPTY	FULL (WATER)	47 5/8"	3995
FULL (WATER)	EMPTY	63 1/8"	4611
FULL (WATER)	FULL (WATER)	57 1/8"	5446
HYDRAULIC RESERVOIR ON HPU FULL, FUEL TANK FULL, ANTI-FREEZE TANK FULL			

WEIGHT AND CENTER OF GRAVITY TABLE FOR MAX WEIGHT CONFIGURATION. INSTALLED: POWER PACK KIT WITH HYDRAULICS P/N: 77-230-13, 350 GALLONS SPOILS TANK P/N: 77-432-02-00, ERV-750 KIT P/N: 79-404-00, TM-7 HD PLUS KIT P/N: 17-405-00, HC-100 VITALS CONTROLLER KIT P/N: 79-422-01, LIGHT BAR KIT P/N: 77-420-00, HYDRAULIC HOSE REEL KIT P/N: 77-413-05.HOT WATER HEATER NOT INSTALLED.			
350 GAL SPOILS TANK	100 GAL WATER TANK	"X" (INCHES), APPROX	WEIGHT APPROX. (LBS)
EMPTY	EMPTY	53 3/4"	4246
EMPTY	FULL (WATER)	49 1/2"	5081
FULL (WATER)	EMPTY	62 1/2"	6772
FULL (WATER)	FULL (WATER)	58 5/8"	7606
HYDRAULIC RESERVOIRS FULL, FUEL TANK FULL, ANTI-FREEZE TANK FULL			

Figure 3-11. Weight and center of gravity specifications for Standard Builder Gas skid system.
NOTE: See table in Section 77-000-55 for 250 gallon spoils tank weight and center of gravity.

Chapter 4

Operating Instructions

CURBSIDE CONTROL PANEL

The control panel on the VMS includes controls for engine and hydraulic system functions.



Figure 4-1. Curbside control panel (diesel version).

In This Chapter

CURBSIDE CONTROL PANEL
 ENGINE OPERATION
 HYDRAULIC SYSTEM CONTROLS
 ERV-750 OPERATION
 VACUUM OPERATION
 PRESSURE WASHER OPERATION
 LIGHT BAR OPERATION
 AUXILIARY HYDRAULIC CIRCUIT/HOSE REEL OPERATION
 TM-7 OPERATION (OPTIONAL)
 WATER HEATER OPERATION (OPTIONAL)

Diesel Engine Configurations (77-000-54/60)

The following diagram illustrates the control panel for the VMS with diesel engine.

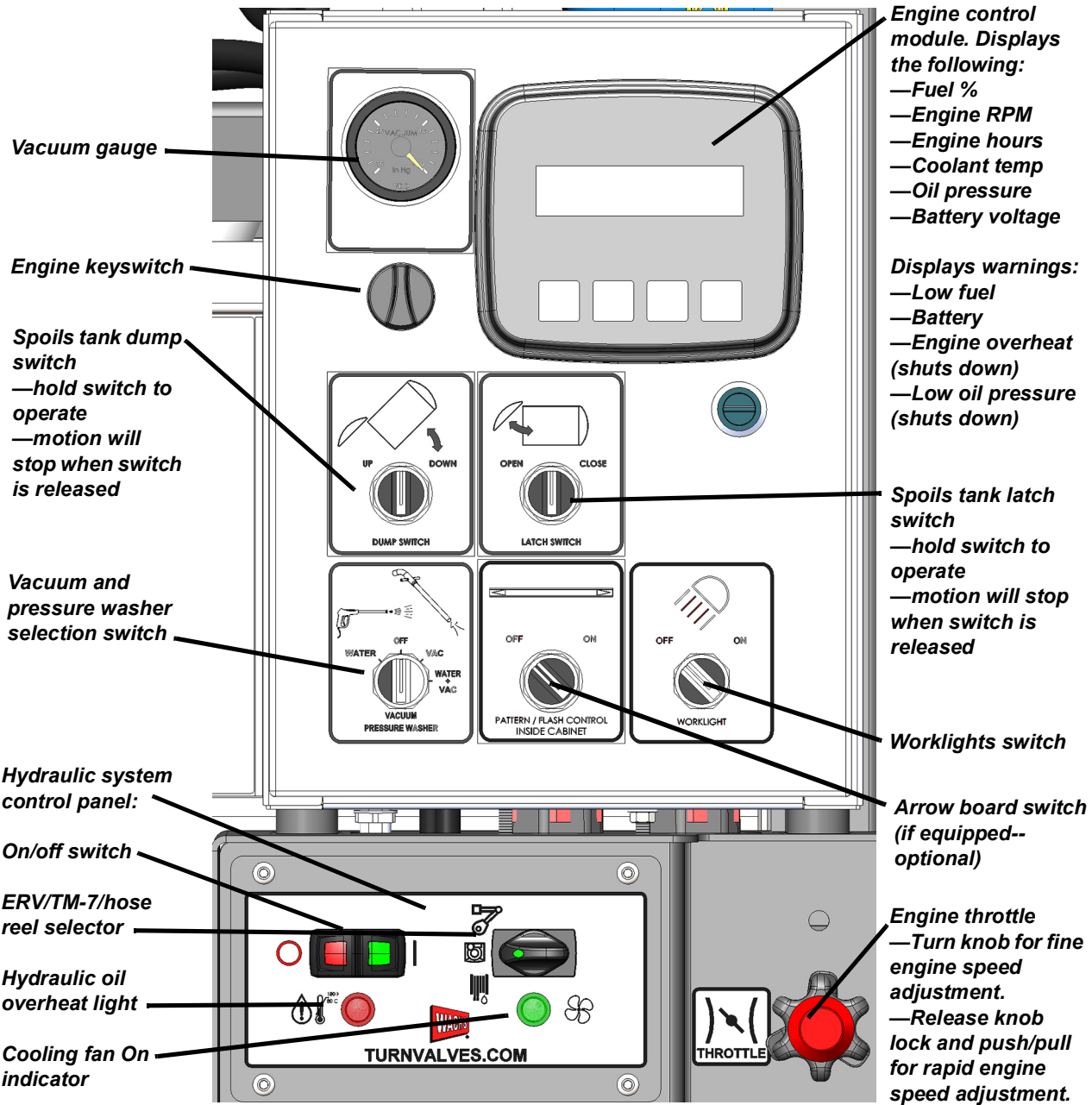

Figure 4-2. The drawing shows the operating features of the diesel configuration control panel.

Gas Engine Configurations (77-000-55/61)

The following diagram illustrates the control panel for the VMS with gas engine.

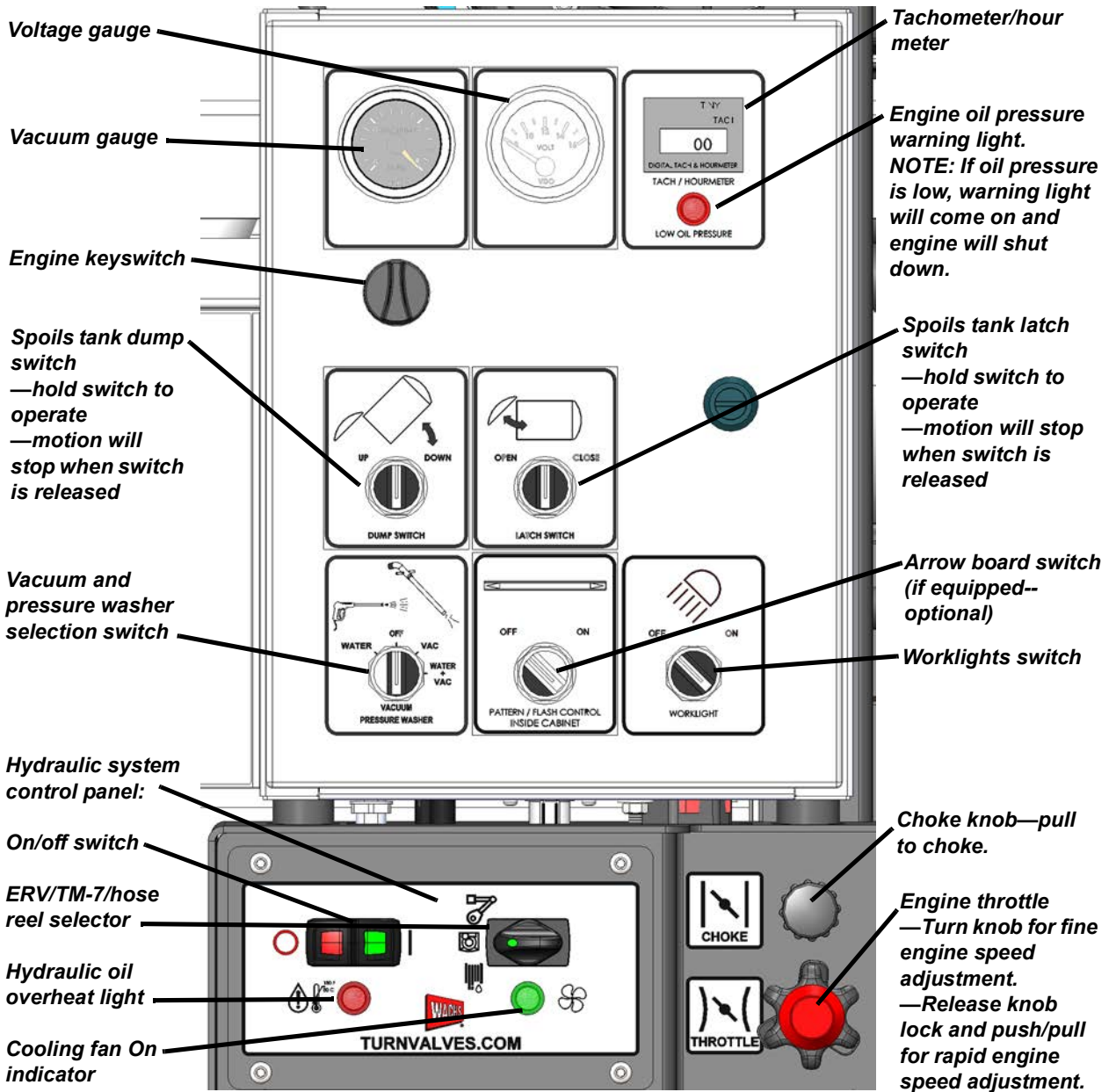

Figure 4-3. The drawing shows the operating features of the gas configuration control panel.

ENGINE OPERATION

The integrated gas or diesel engine provides power to the VMS. The engine must be running to operate the hydraulic-powered components of the system (valve operators, vacuum, pressure washer, hose reel).

You can operate the electrical components of the system without running the engine (spoils tank latch and dump, arrow board, work lights, power inverter). However, you should run the engine if you operate these components for more than a short time, to avoid draining the battery.

- 1.** Before starting the engine, make sure the following control switches are set to the OFF position:
 - Vacuum/pressure washer
 - Pattern/flash control
 - Worklights
 - Hydraulic system.
- 2.** Use the keyswitch to start the engine.
- 3.** Allow the engine to warm up before throttling it up to operating speed.
- 4.** Use the throttle knob to set the engine speed. The throttle knob has a lock to keep the engine speed constant during operation.
 - Loosen the lock to adjust the throttle.
 - Tighten the lock to fix the engine speed at the throttle setting.



NOTE

See specific starting notes for each engine, including cold-weather starting, in the following diesel and gas engine subsections.

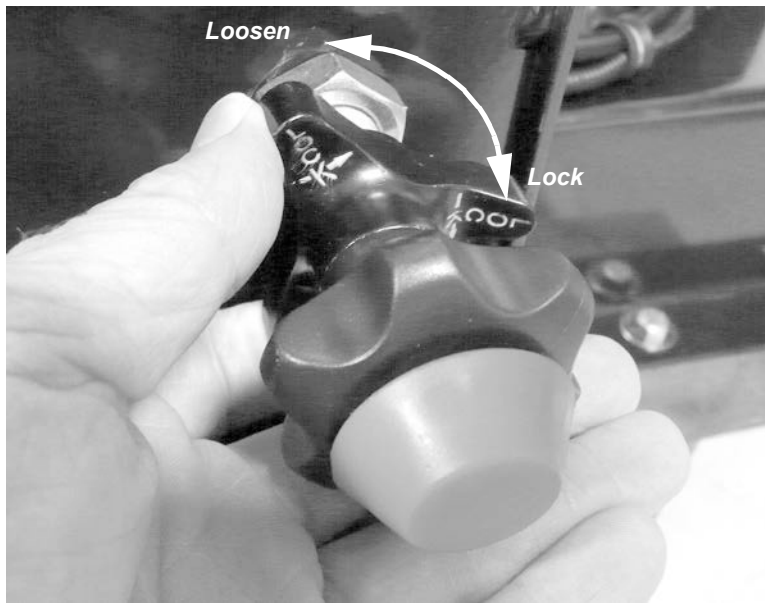

Figure 4-4. Loosen the throttle lock to adjust the throttle. Tighten the lock to keep the engine speed constant.

- 5.** For fine adjustment of the engine speed, turn the throttle knob:
- counter-clockwise to increase speed
 - clockwise to decrease speed.

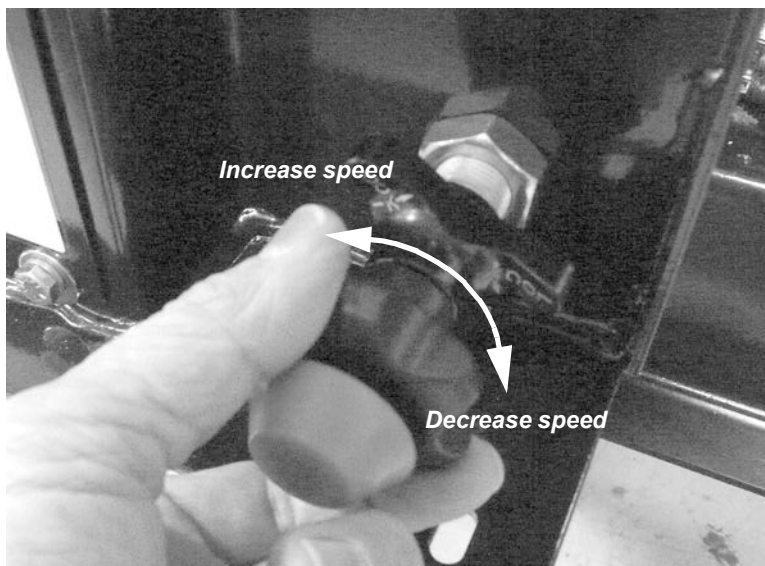

Figure 4-5. For fine engine speed adjustment, turn the throttle knob.

- 6.** For rapid adjustment of the engine speed, push the button on the throttle to push/pull it:
- pull the throttle out to increase engine speed
 - push the throttle in to decrease engine speed.

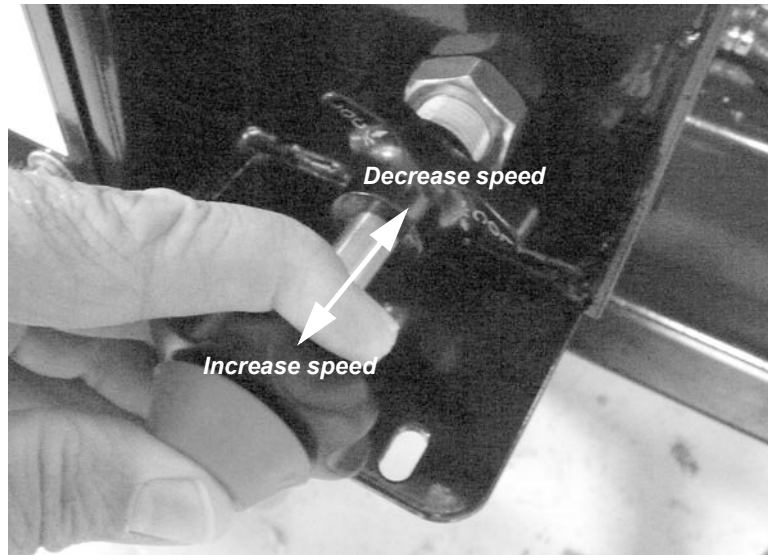

Figure 4-6. For rapid engine speed adjustment, hold the throttle button and push or pull the throttle.

Refer to specific operating notes in the following subsections for your engine configuration (diesel or gas).

Diesel Engine Starting and Operation

The diesel engine has a built-in 400 W block heater (110 V) to keep the engine warm in cold environments. Plug in the block heater to pre-warm the engine for easier starting in cold weather.

When you turn on the keyswitch, a countdown timer appears on the control panel display while the ignition plugs are pre-warmed. Wait until the timer counts down to start the engine.

Gas Engine Starting and Operation

When starting the engine cold, pull out the choke knob before starting. Allow the engine to warm up, then push in the choke and set the throttle speed.

HYDRAULIC SYSTEM CONTROLS

Use the hydraulic system control panel to turn the hydraulics on and off, and to select the hydraulic tool.

- The engine must be running to operate the hydraulic system.
- For safety, the hydraulic system is off when the engine is first started.

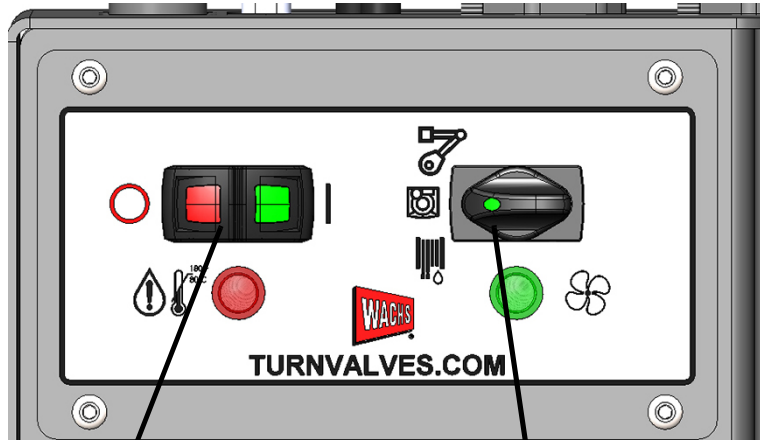

On/off switch

- Engine must be on to operate hydraulic system.
- Push green to turn on.
- Push red to turn off.
- Hydraulic system is always OFF when engine is first started.

Hydraulic tool selector

- ERV 750
- TM-7 (if equipped)
- hydraulic hose reel.

Figure 4-7. Use the control panel to turn the hydraulic system ON/OFF, and to select the hydraulic tool.

ERV-750 OPERATION

This section describes how to set up the ERV-750 for use. Detailed instructions on operating the ERV-750 are in the *ERV-750 Extended Reach Valve Operator User's Manual*, which is provided with the ERV-750.

- 1.** Unfasten the latches that hold the ERV arm in place.



Figure 4-8. Release the two latches that secure the ERV-750 arm to the truck.

- 2.** Operate the ERV-750 according to the instructions in the *ERV-750 Extended Reach Valve Operator User's Manual*.
- 3.** When you are finished using the ERV-750, return the arm to its storage position and fasten it with both latches.

VACUUM OPERATION

When using the vacuum system, you should do the following at the end of the workday:

- Empty the spoils tank. (See “Emptying the Tank” on page 55.)
- Lubricate the blower. (See “Lubricating the Blower” on page 61.)

Selecting a Vacuum Wand

Three vacuum wands of different diameters are provided with the VMS:

- 7/8” diameter x 8 ft vacuum wand.
- 1-1/4” diameter x 8 ft vacuum wand.
- 2-1/2” diameter x 8 ft vacuum wand.

In general, use the largest wand you can for the work environment. Larger wands pick up more debris faster and are

less likely to clog. Use a smaller wand when you need to work in a tight area.

Setup and Operation

Before setting up the vacuum system, position the vehicle so that the suction hose reaches the work area.

- Make sure that the latch on the dump door of the holding tank is fully engaged.
 - Make sure the holding tank drain valve is closed.
 - Make sure that the vacuum break lever on the back of the truck is in the CLOSED position.
- 1.** Park the vehicle on level ground in a location close enough to the work site to reach it with the suction hose.
 - 2.** Remove the suction hose from its storage location on the back of the spoils tank and lay it out on the ground.
 - 3.** Release the locking collar holding the plug in the inlet port at the top of the spoils tank.



Figure 4-9. Pull the latch on the locking collar to release it and take it off the inlet port.

- 4.** Remove the plug from the inlet port. Put the plug in a secure location such as the truck storage box.



NOTE

The standard suction hose is 20 feet long (longer length hoses can be ordered).



Figure 4-10. Remove the plug from the inlet port.

- 5.** Insert the port fitting end of the suction hose into the inlet port. Put the locking collar over the fitting and close the latch to secure the hose.



Figure 4-11. Insert the hose fitting into the inlet port and attach it with the locking collar.

- 6.** Slide the elbow fitting (with handles) over the end of the vacuum wand.



Figure 4-12. Slide the elbow onto the end of the wand. Align the locking pin in the elbow with the slot on the wand fitting.

- 7.** Insert the wand fully into the elbow until the lock pin engages.



Figure 4-13. Insert the elbow into the wand until the lock pin engages to secure the wand.

- 8.** Start the engine, following the instructions in “Starting and Running the Engine” earlier in this chapter.
- 9.** Before turning on the vacuum blower, make sure you are holding the wand off the ground and away from any objects.



NOTE

Set the engine throttle to low speed before turning on the pressure washer or vacuum blower.

- 10.** At the control panel, turn the Vacuum/Pressure Washer switch to the VAC position. The vacuum blower will engage.

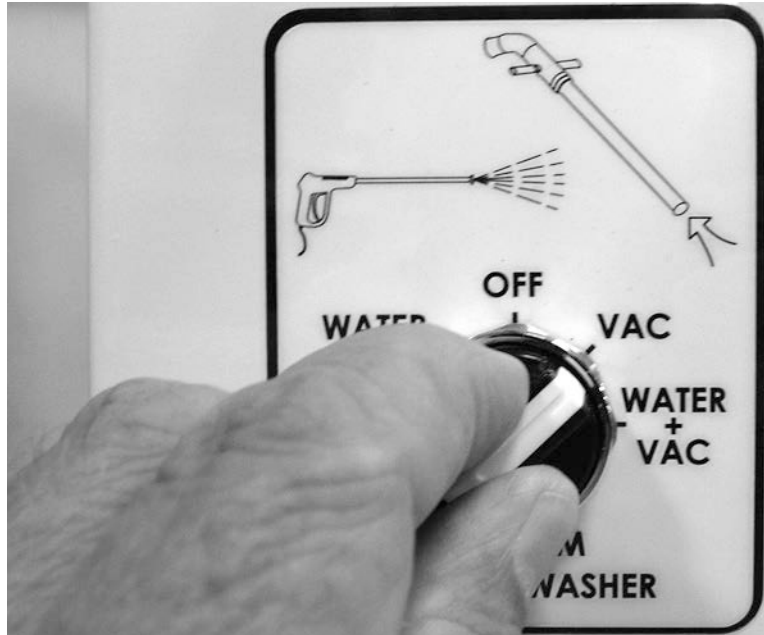

Figure 4-14. Turn the Vacuum/Pressure Washer switch to the VAC position.

- 11.** If you are using the pressure washer to aid in vacuuming, turn the Vacuum/Pressure Washer switch to the BOTH position.

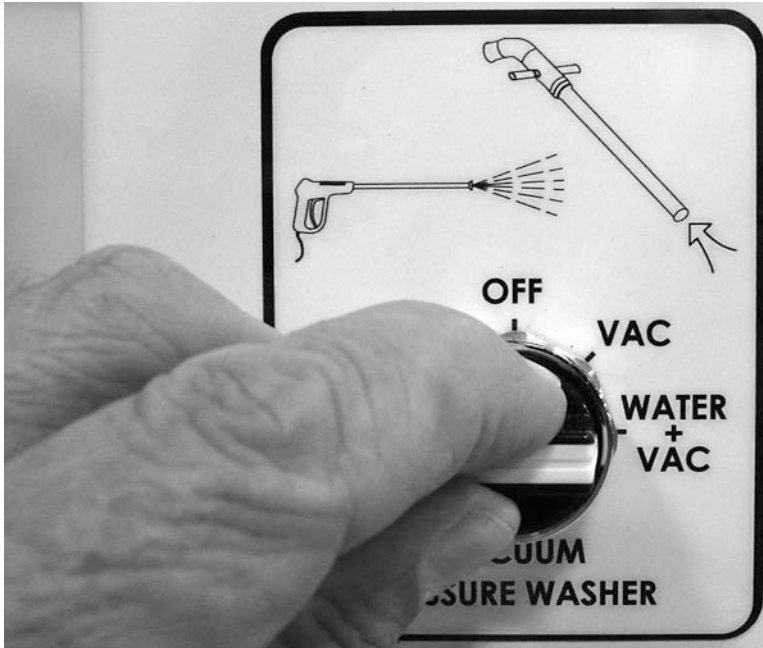

Figure 4-15. To use both the washer and vacuum, turn the Vacuum/Pressure Washer switch to the WATER + VAC position.

- 12.** Vacuum the work site to remove the water or debris. Note the following guidelines when operating the vacuum:
- When vacuuming water, do not submerge the tip of the wand. Skim the surface of the water with the wand to keep from opening the vacuum relief valves.
 - Monitor the vacuum pressure. Normal operation should have a vacuum level of about 5". If the filter or wand is clogged, the vacuum will rise to 11". Shut the vacuum off and check the filter and wand or hose.
 - Vacuuming dry debris may be easier if you use the pressure washer to wet the material into a slurry.
 - You can "dig" with the pressure washer to loosen and remove material around hydrants or other equipment.
 - **Follow all safe digging practices and guidelines required for the worksite.**



Monitor the pressure on the vacuum gauge while operating the vacuum.



CAUTION

Do not fill the spoils tank to a level that exceeds the maximum Gross Vehicle Weight Rating (GVWR) of the vehicle and skid. Check the label inside the driver's door for available vehicle payload. See the **SPOILS WEIGHT** sticker on the tank for estimating the weight of the spoils in the tank.



NOTE

A clogged wand or hose will also stop vacuum suction. If the suction stops and the tank is not full, see the instructions in the "Unclogging the Vacuum" section below.



IMPORTANT

After using the vacuum system and emptying the tank, lubricate the blower. See "Lubricating the Blower" on page 61.

- 13.** You can monitor the fill level of the spoils tank by checking the sight glass on the front of the tank. The sight glass is at the 60% fill level.

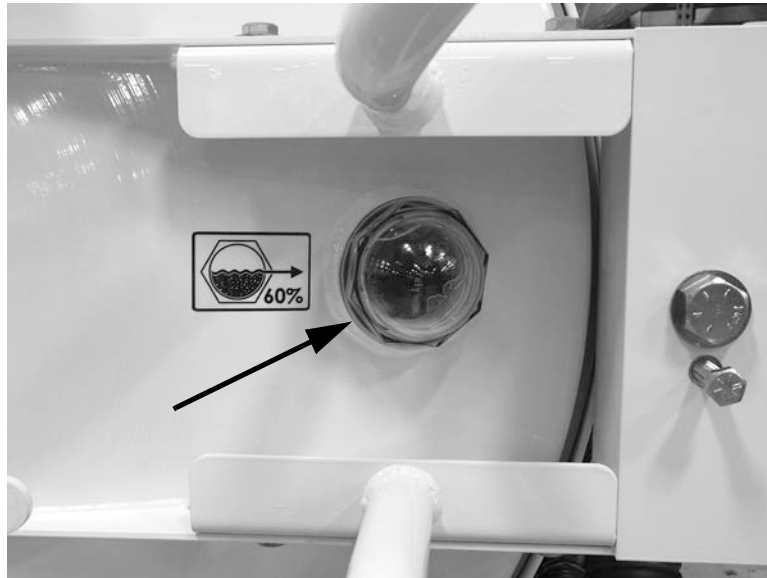

Figure 4-16. Monitor the fill level of the tank using the sight glass.

- 14.** When the tank fills with liquid, a ball valve in the top of the tank shuts off the vacuum pressure. (The relief valves in the filter canister will open.) See the instructions in the next section, "Emptying the Tank".
- 15.** When you are finished vacuuming or when the vacuum pressure stops, turn the Vacuum/Pressure Washer switch to the OFF position.

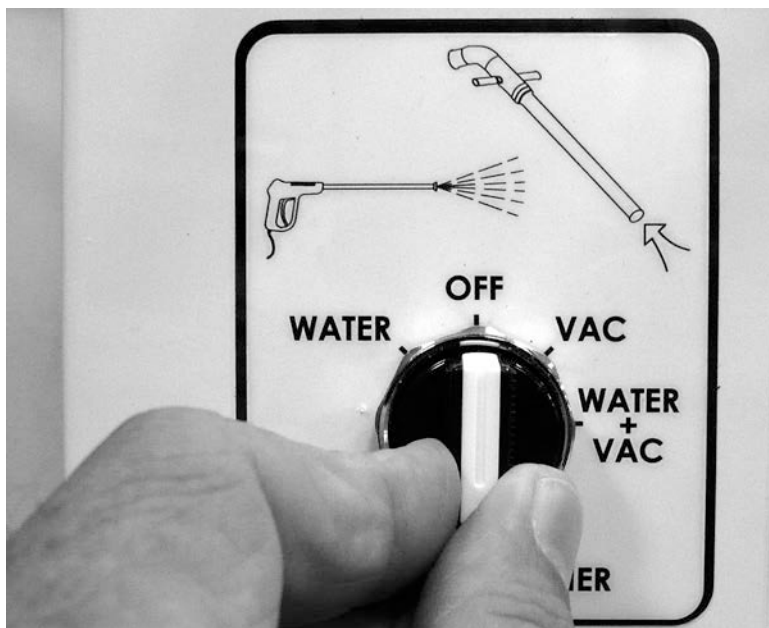

Figure 4-17. Turn the Vacuum/Pressure Washer switch OFF to turn off the vacuum.

16. Turn off the engine using the keyswitch.
17. Remove the wand from the suction hose and put it in the accessory storage box.
18. Remove the hose from the tank inlet port and replace it on the back of the truck.
19. Put the plug back in the inlet port and secure it with the locking collar.

Emptying the Tank

Follow the procedure below for draining liquid or dumping solids from the tank. If the tank contains both liquid and solids, first drain the liquid, then dump the solids.

Dump the spoils tank only in authorized dumping areas.



WARNING

Keep personnel away from the rear of the truck when dumping the spoils tank. Serious injury could result from contact with moving parts.



NOTE

The tank moves out 12" before it tips for dumping, and the door swings out when opened. Allow sufficient clearance behind the truck.



NOTE

If the valve is blocked with solids and the liquid won't drain, it is easiest to dump the tank to empty it. Stand clear of the tank when dumping liquids; the tank contents will splash out when the door is opened.

Draining Liquid

- 1.** Move the truck to the dumping location. If you will be dumping solids, make sure there is clearance for the tank to open and dump.
- 2.** Open the tank drain valve to allow the liquid to drain.

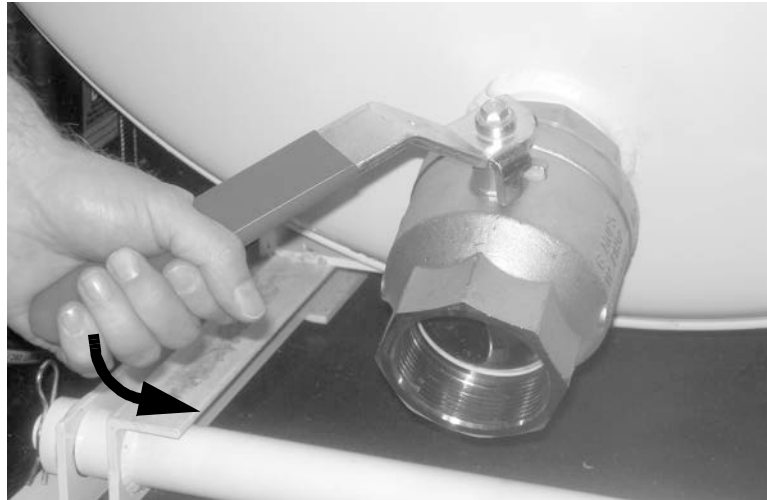

Figure 4-18. Open the tank drain valve to allow liquid to drain from the tank.

- 3.** When the liquid has finished draining, check the tank drain valve to make sure there are no obstructions blocking the tank drain.



Figure 4-19. Check the drain valve before closing it to make sure there are no obstructions.

- 4.** Close the tank drain valve.



Figure 4-20. Close the tank drain valve when the liquid has finished draining.

- 5.** If you are finished with the equipment, turn off the engine.

Dumping Solids

If there is liquid in the tank, drain it before dumping the solids.

- 1.** Move the truck to the dumping location. Make sure there is clearance for the tank to open and dump.
- 2.** Start the gas engine, following the instructions in “Starting and Running the Engine” earlier in this chapter.
- 3.** At the control panel, turn and hold the Dump Switch to the UP position. Hold the switch until the tank is fully tipped up, then release it to the center position.



CAUTION

Park the truck on level ground before dumping. You may not be able to close the door if the truck is not level.



WARNING

Make sure no one is in front of or near the tank when operating the Dump Switch. Contact with the tank while it is moving could cause serious injury.

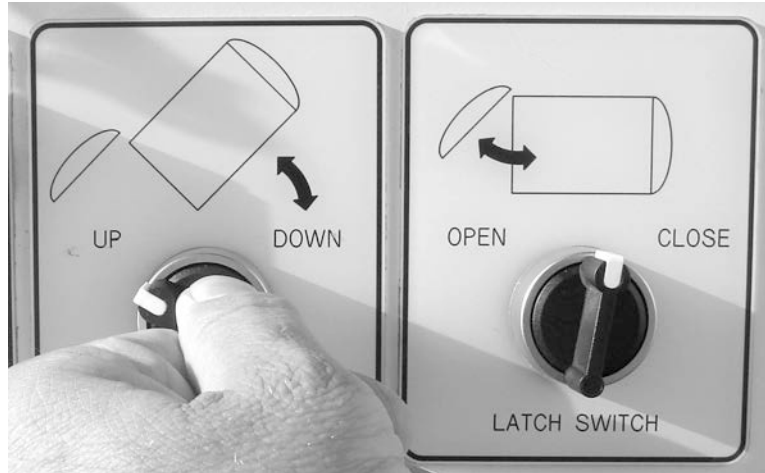

Figure 4-21. Turn the Dump Switch to the UP position and hold it until the tank is completely tipped.



Figure 4-22. Tip the tank fully before opening the tank door.



WARNING

Make sure no one is in front of or near the tank when operating the Latch Switch. Contact with the tank door or contents when the door opens could cause serious injury.

4. At the control panel, turn the Latch Switch to the OPEN position and hold it until the door opens.



Figure 4-23. Turn the Latch Switch to the OPEN position and hold it until the door swings open.



Figure 4-24. The tank door will swing open when the latches are released.

- 5.** After the tank contents have dumped and the door has stopped swinging, check the inside of the tank for remaining debris. Remove debris with the power washer, or use a shovel to scrape it out if necessary.
- 6.** Use the power washer to clean the rim of the door and the tank where they contact each other. This will ensure the tank door will seal properly when you close it.



WARNING

Make sure no one is near the tank when operating the Dump and Latch Switches. Contact with the tank or door when they are moving could cause serious injury.

7. At the control panel, turn the Dump Switch to the DOWN position and hold it until the tank has lowered and moved back to its operating position. Release the Dump Switch.

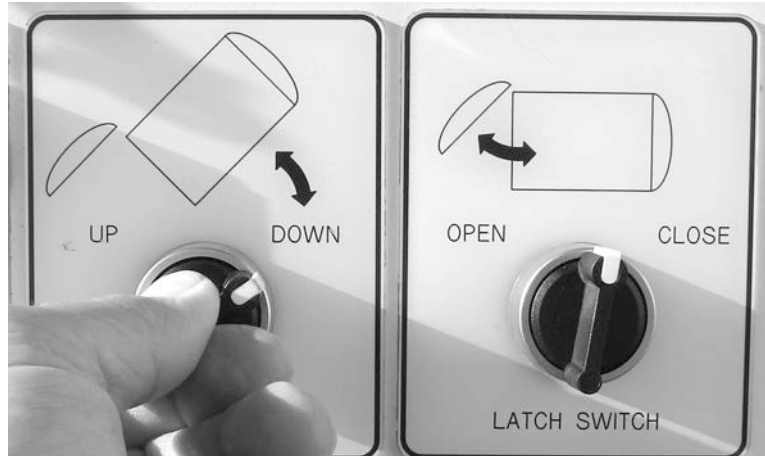

Figure 4-25. After the tank is dumped, turn the Dump Switch to the DOWN position until the tank has moved back to its operating position.

8. Make sure the door is in contact with the tank before operating the Latch Switch.
9. At the control panel, turn the Latch Switch to the CLOSE position and hold it until the latches on the door completely engage.



CAUTION

Make sure the tank is lowered to its level position before closing the door. If you close the door latches before setting the tank down, you could damage the latch mechanisms.

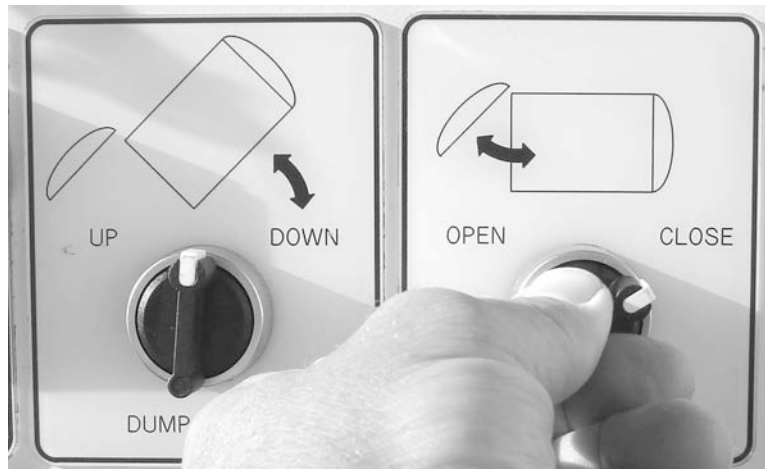

Figure 4-26. When the tank is in the down position, turn the Latch Switch to the CLOSE position until the latches are fully engaged.

10. If you are finished with the equipment, turn off the engine.

Lubricating the Blower

To prevent corrosion, lubricate the blower at the end of the day with a spray lubricant such as WD-40. Apply the spray through the port on the powerpack.

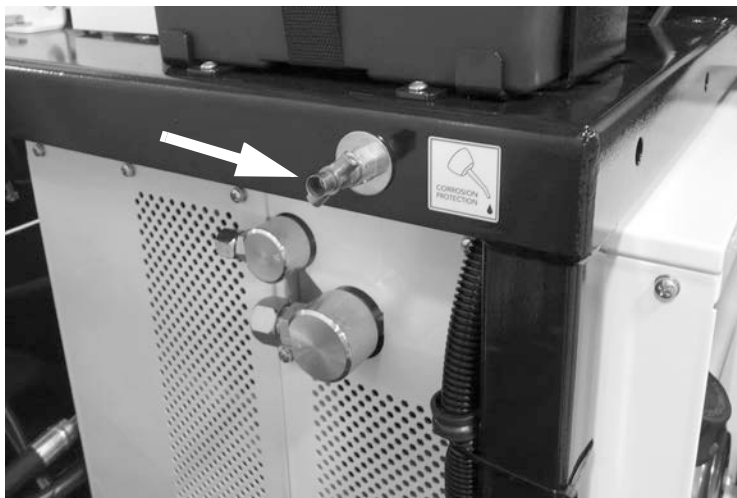

Figure 4-27. There is a blower lubrication port on the powerpack frame.

IMPORTANT: Empty the spoils tank before lubricating the blower, to reduce recirculation of moisture and debris.

1. Start the engine and run it at medium throttle.
2. At the curbside control panel, turn the Vacuum/Pressure Washer switch to the VAC position. The vacuum blower will engage.

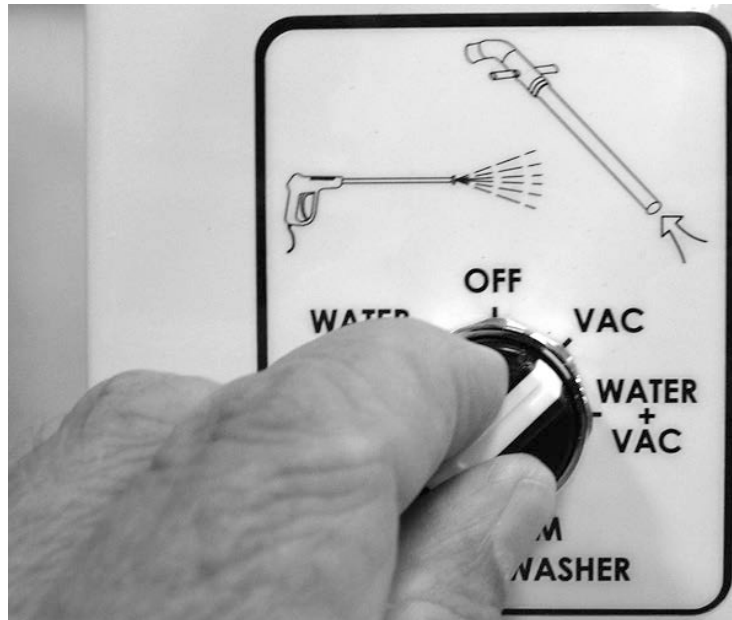

Figure 4-28. Turn on the vacuum to lubricate the blower.

3. Turn the blower lubrication port fitting **clockwise** to open the port.



Figure 4-29. Open the blower lubrication port.

4. Spray lubricant (WD-40 or equivalent) into the port for 15-30 seconds while the blower is running.
5. Turn the blower lubrication port fitting **counter-clockwise** to close the port.



Figure 4-30. Close the blower lubrication port after spraying the lubricant.

6. At the curbside control panel, turn the Vacuum/Pressure Washer switch to the OFF position.

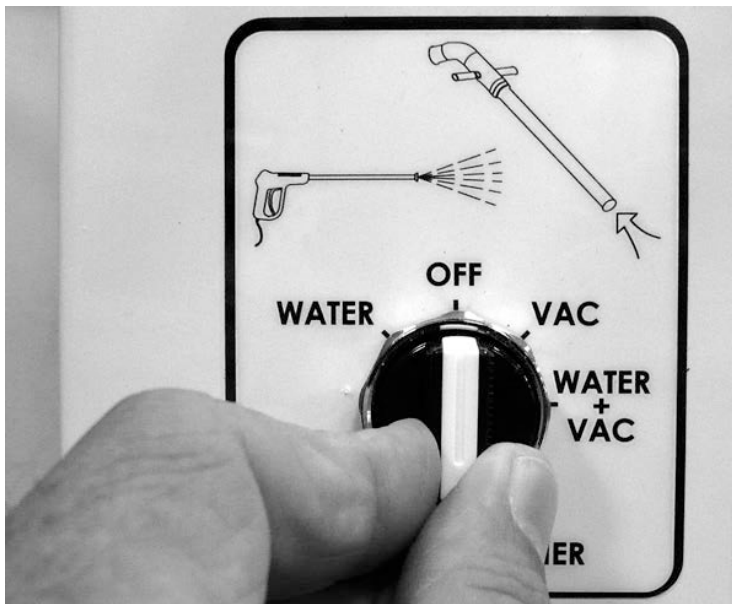

Figure 4-31. Turn the Vacuum/Pressure Washer switch to OFF after lubricating the blower.



CAUTION

Make sure the lubrication port is closed after you finish the lubrication.



NOTE

Also check the filter whenever the vacuum system becomes clogged. Reduced suction caused by a partially clogged filter could cause the hose to clog. Clean the filter if necessary.

Unclogging the Vacuum

If the system loses suction and the tank is not full, there is either a clog in the wand or hose, or the filter is plugged. If the suction stops suddenly, a clog is the most likely cause. A gradual decrease of suction is probably caused by a plugged filter.

Use the following procedure to clear the clog. Instructions for cleaning the filter are in Chapter 6.

1. With the vacuum still running, turn the Vacuum Break lever to the CLOSED position, then return it to the OPEN position. This may dislodge the clog.

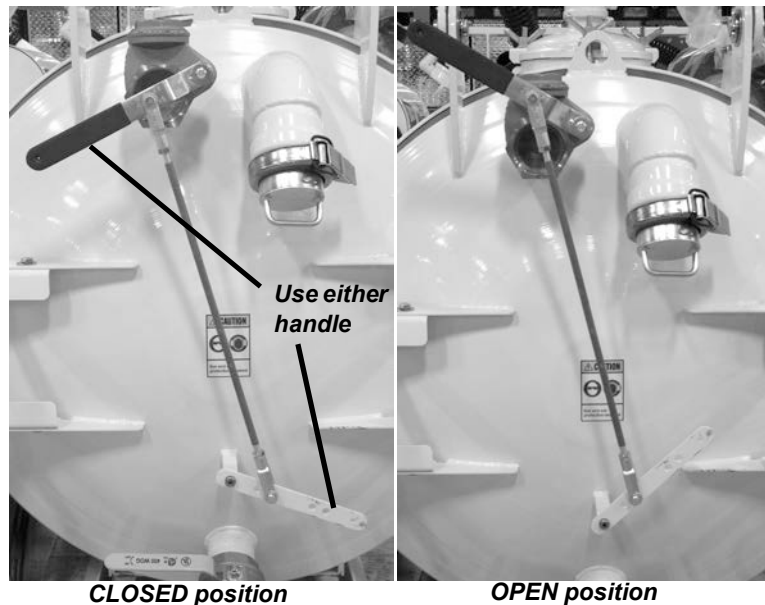

Figure 4-32. Turn the Vacuum Break lever to the CLOSED position.

2. Repeat opening and closing the Vacuum Break lever one or two times to see if the clog dislodges.
3. If using the Vacuum Break lever does not dislodge the clog, return the lever to the OPEN position. Turn the Vacuum/Pressure Washer switch to the OFF position to turn off the vacuum.

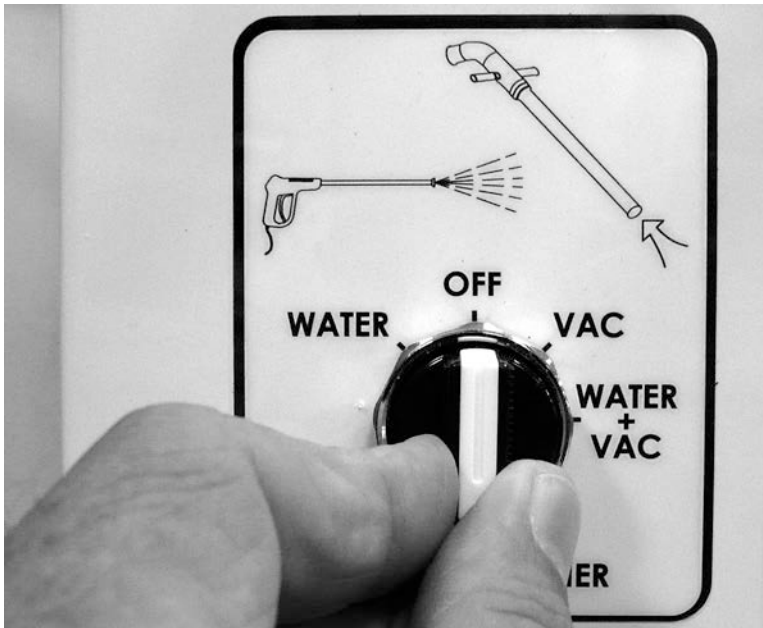

Figure 4-33. Turn the Vacuum/Pressure Washer switch OFF to turn off the vacuum.

4. Remove the wand from the hose and look through it to check for an obstruction. If it is blocked, use a rod or similar tool in the connector end of the wand to push the obstruction out.
5. If the wand is not clogged, remove the hose from the inlet port and check it. Try using the pressure washer from the tank end of the hose to spray out the clog, or use a long rod or similar tool to push the clog back out of the hose.
6. When you have removed the clog, reconnect the wand to the hose. Spray water into the tank end of the hose to make sure it comes out the wand.
7. Reconnect the hose to the inlet port on the tank.

PRESSURE WASHER OPERATION

Before operating the pressure washer, check the following:

- Make sure there is water in the washer reservoir.
- If the temperature will be below freezing, make sure there is antifreeze in the antifreeze reservoir.

- Make sure the Water Supply Valve lever is in the “Tanks” position.

The following photo illustrates the pressure washer fittings.

- Recirculation fitting—connect the sprayer hose to this fitting to recirculate water through the system (see “Recirculation” at the end of this section). Keep the sprayer hose “parked” here when not using the pressure washer.
- Tank fill inlet—connect a garden hose to this fitting to fill the pressure washer tank. (A backflow preventer at the tank keeps the tank from draining when you disconnect the hose.)
- Sprayer hose—connect the hose to a sprayer wand for operation. Keep it connected to the recirculation fitting when not using the pressure washer.
- Tank drain outlet—turn the faucet handle to open the outlet and drain the tank.

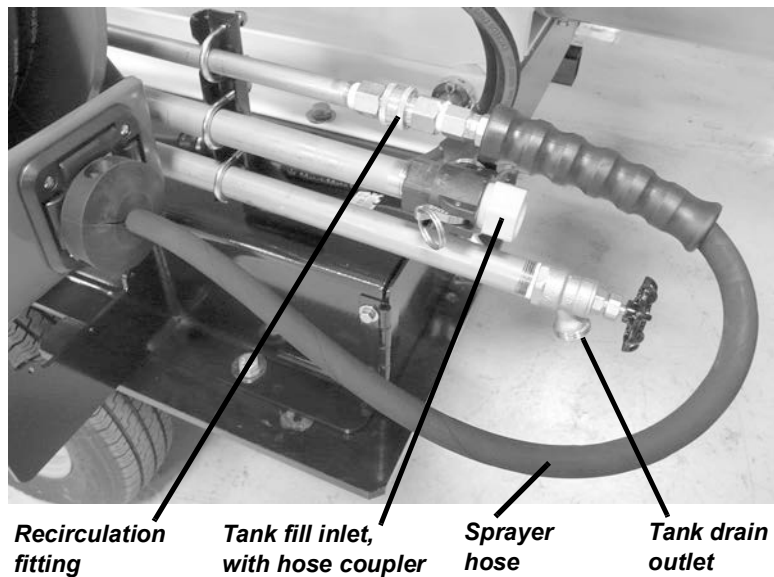

Figure 4-34. The photo shows the pressure washer and tank connections.

When you are using the system in low-temperature (freezing) conditions, you should operate the pressure washer pump with the sprayer hose connected to the recirculation fitting. See “Recirculation” on page 76.

See Chapter 4 for instructions on storing the pressure washer in sub-freezing weather.

Filling the Water Tank

To fill the water tank, connect a garden hose to the hose inlet connection at the back of the truck, by the hose reel. See Figure 4-34.

The inlet line has a NSF dual-check backflow preventer, beneath the water tank. This prevents the tank from draining through the inlet.

You can also fill the tank by removing the top cap.



Figure 4-35. You can remove the lid from the top of the water tank to fill it.

Filling the Antifreeze (Primer) Tank

The priming tank is by the engine at the front of the truck bed. Unscrew the cap and fill the tank before using the sprayer.

- When operating the sprayer in below-freezing or near-freezing weather, keep the priming tank filled with an antifreeze mixture appropriate for the temperature.
- When there is no danger of freezing temperatures, you can keep plain water in the tank. You can use a water treatment solution to keep the sprayer system clean.



NOTE

There is a NSF dual-check backflow preventer on the inlet line, beneath the water tank. This prevents the tank from draining through the inlet. When you disconnect the supply hose from the inlet, only water in the pipe will drain out.

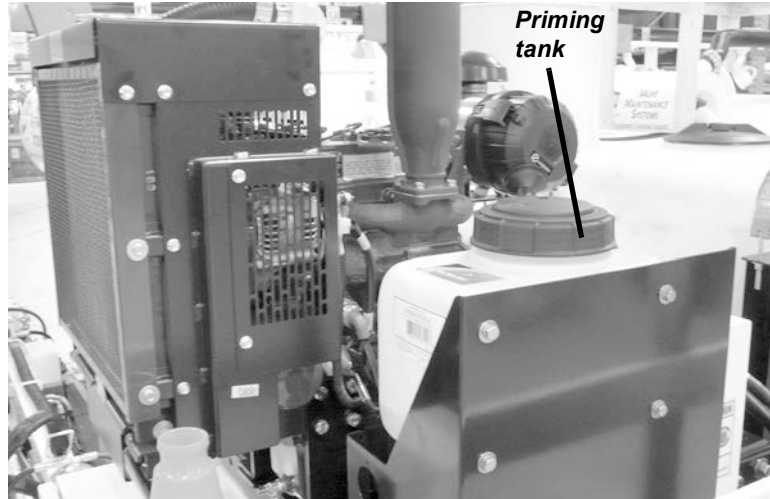

Figure 4-36. In **freezing** weather, fill the priming tank with an antifreeze mixture. In **non-freezing** weather, use water treated with a purifying agent.

Using the Pressure Washer

The short sprayer wand is recommended for washing down the truck or cleaning other equipment. The longer wand is useful for cleaning at the work site or scouring soil and debris while vacuuming.



NOTE

The sprayer hose is 50 feet long. The hose reel has a ratchet lock; when you have pulled out the desired length of hose, stop pulling when you hear the ratchet click.

1. Pull enough sprayer hose from the hose reel to reach the work location.

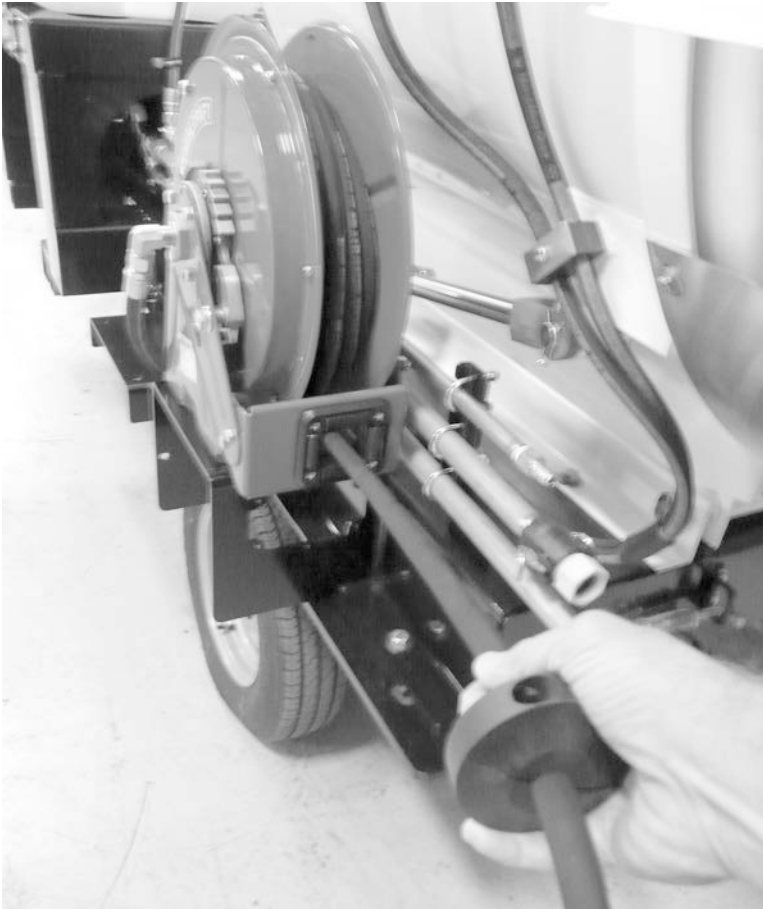

Figure 4-37. Pull the sprayer hose out of the hose reel until you can reach the work location.

- 2.** Select the sprayer wand you want to use. Attach the wand to the end of the sprayer hose. Two standard sprayer wands are provided:
 - The wash-down wand (77-406-00) with a 40° nozzle is used for cleaning.
 - The rotating-nozzle wand (77-408-01) is used for hydro-excavation.

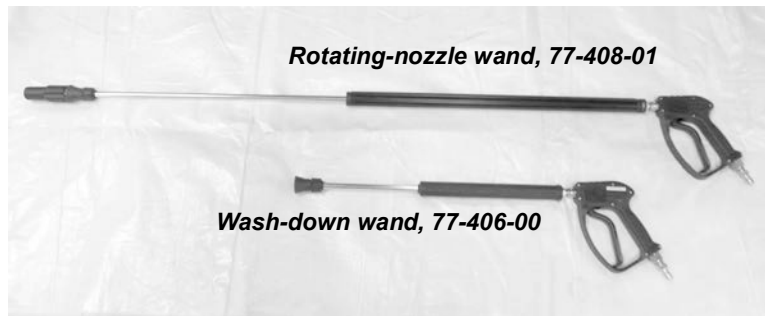

Figure 4-38. The photo shows the 2 sprayer wands.



Figure 4-39. Attach the spray wand to the sprayer hose.



NOTE

Set the engine throttle to low speed before turning on the pressure washer or vacuum blower.

3. Start the gas engine and run at low to medium throttle.
4. At the control panel, turn the Vacuum/Pressure Washer switch to the WATER position.

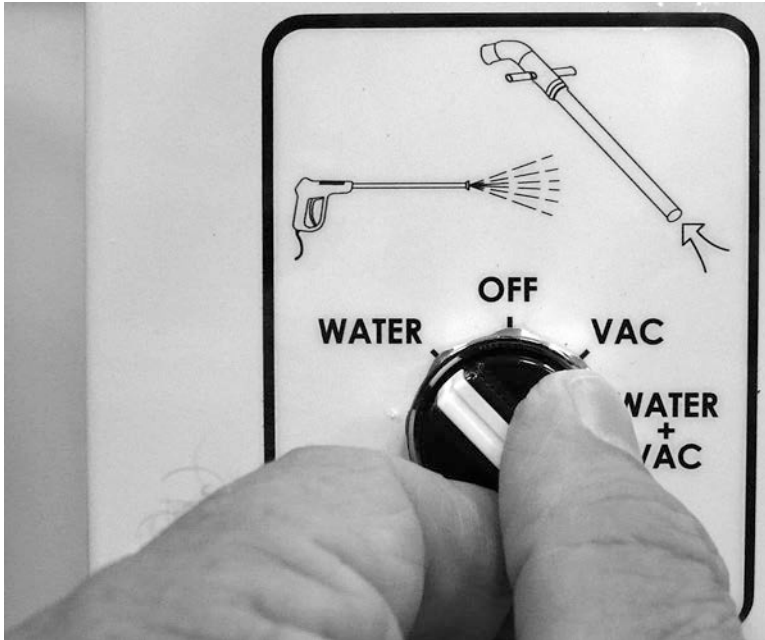

Figure 4-40. Turn the pressure washer switch to the WATER position.

5. If you will be using both the pressure washer and vacuum, turn the Vacuum/Pressure Washer switch to the WATER + VAC position.

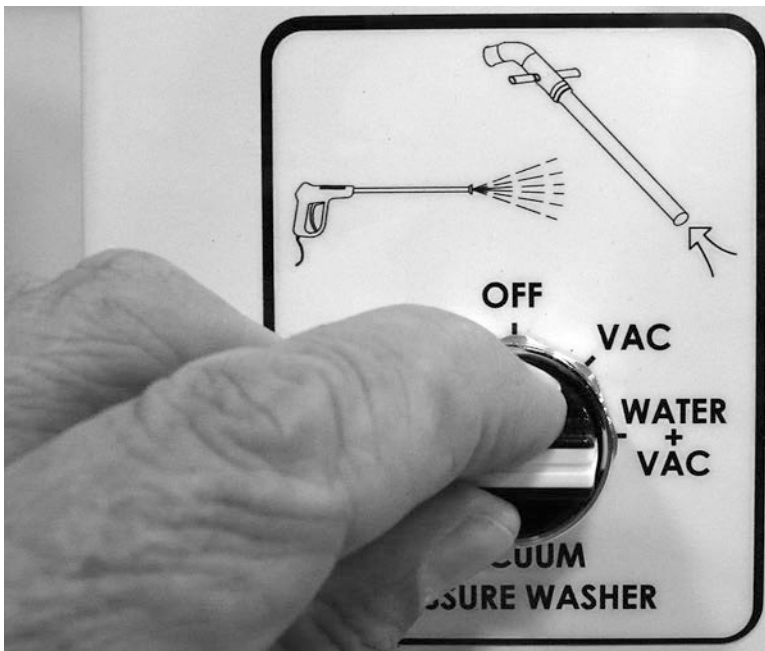

Figure 4-41. To use both the washer and vacuum, turn the Vacuum/Pressure Washer switch to the WATER + VAC position.



CAUTION

Never exceed 3,000 psi (206 bar) pressure.

6. Squeeze the trigger on the spray wand to start spraying.
7. Adjust the sprayer pressure by turning the unloader knob on the sprayer pump.

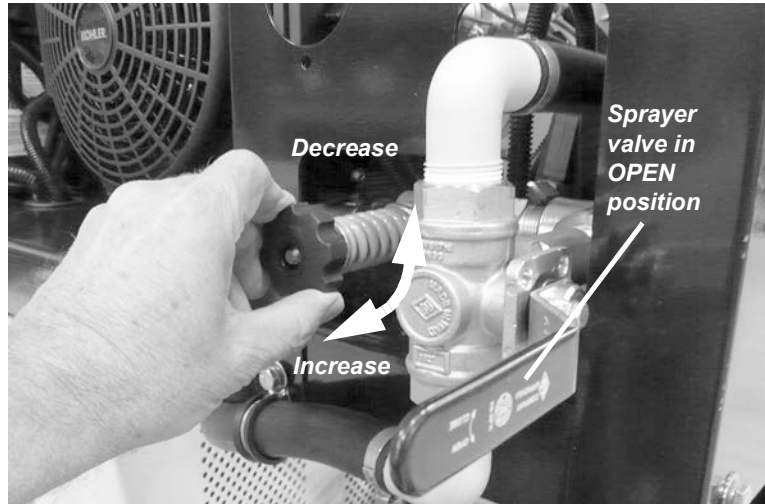

Figure 4-42. Turn the unloader knob clockwise to increase the water pressure, or counter-clockwise to decrease water pressure.

8. Monitor the water level in the water tank while using the sprayer. Refill the tank when necessary. If the tank runs dry and the pump loses its prime, follow the priming procedure in the next section.
9. When you are finished spraying, turn the Vacuum/Pressure Washer switch to the OFF position.

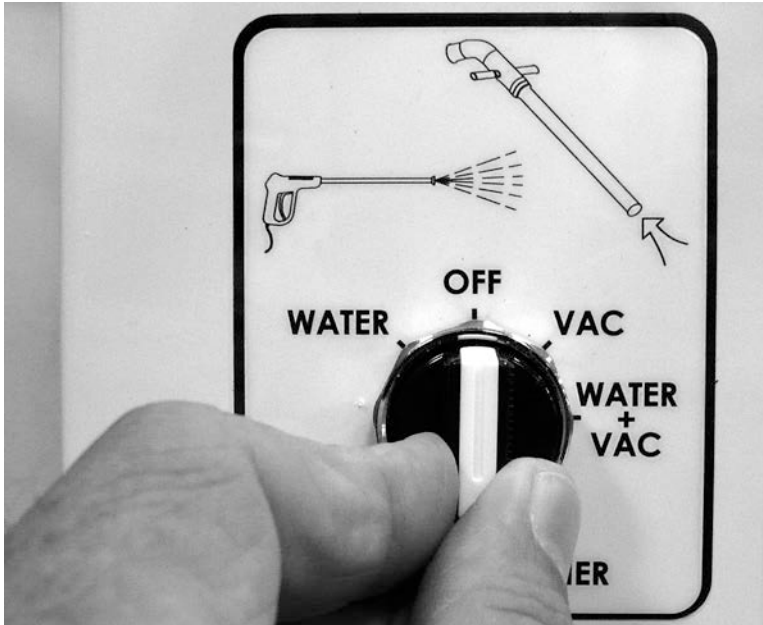

Figure 4-43. Turn the Vacuum/Pressure Washer switch OFF when you are done using the sprayer.

Priming the Washer Pump

You may need to prime the washer pump if the tank runs dry, or if the system is drained because of a leak or service. You can prime the pump using its own pressure or using an external pressurized water source.

Prime Using the Pump Pressure

1. Fill the main water tank with water.
2. Fill the priming tank with water.



NOTE

Any loose or cracked fittings, or air trapped in the suction line, will prevent the water pump from operating correctly.



CAUTION

Do not move the Water Supply Valve lever when the pump is running. Damage to the pump could result.

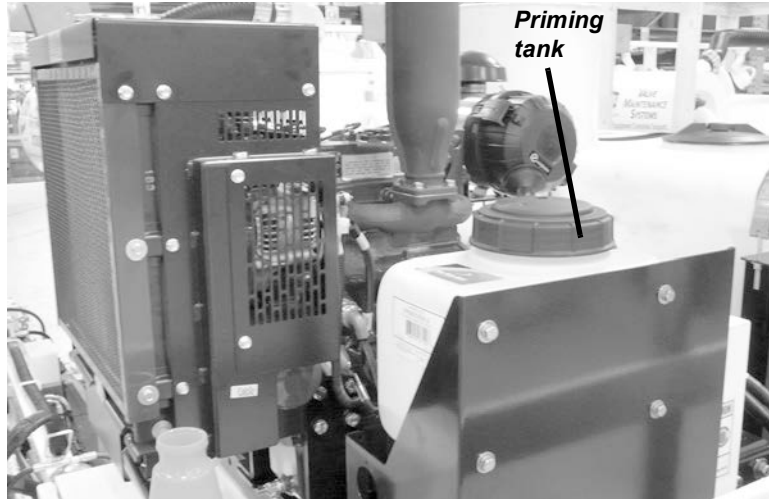

Figure 4-44. Remove the lid to fill the priming tank.

3. Move the yellow Water Supply Valve lever (in front of the left fender) to the “Antifreeze/Charge Tank” position.
4. Pull enough hose from the sprayer hose reel to reach the priming tank. Put the end of the sprayer hose into the top of the tank to cycle the antifreeze as you prime the system.
5. Loosen the clear plastic water strainer until fluid fills the bowl, then re-tighten. (The suction supply line should now be primed from the priming tank to the strainer housing.)

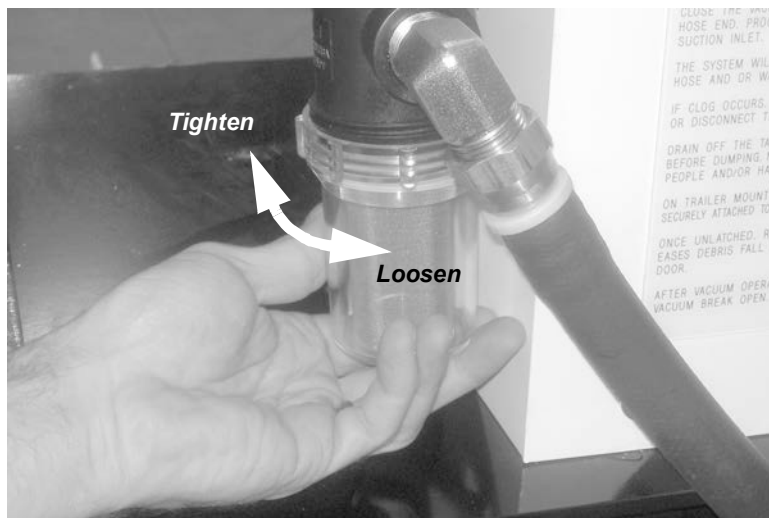

Figure 4-45. Loosen the strainer until water fills the bowl, then re-tighten it.

6. Turn the unloader knob counter-clockwise to release all spring tension.

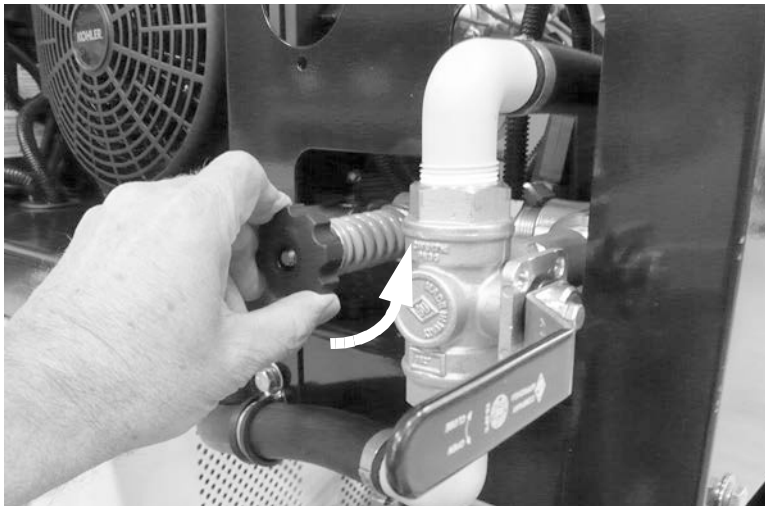

Figure 4-46. Turn the unloader knob counter-clockwise until the spring tension is released.

7. Start the engine and run at low to medium throttle.
8. At the control panel, turn the Vacuum/Pressure Washer switch to the WATER position. Water will begin to flow from the end of the sprayer hose.

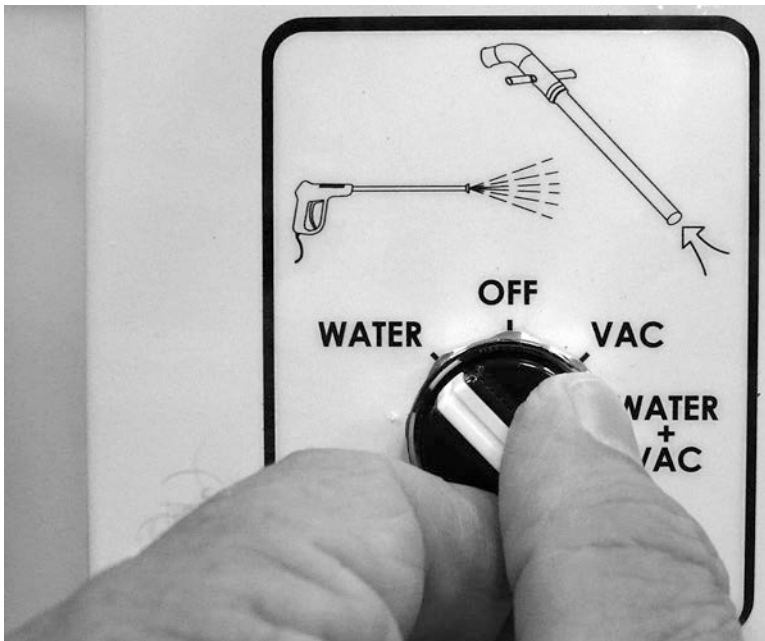

Figure 4-47. Turn the pressure washer switch to the "Water" position.



NOTE

Set the engine throttle to low speed before turning on the pressure washer or vacuum blower.



CAUTION

Do not move the Water Supply Valve lever when the pump is running. Damage to the pump could result.



CAUTION

Always turn the switch OFF when connecting or disconnecting the sprayer hose.

9. Let the water continue to flow until it is a steady flow, with no air bubbles. This could take up to 3-5 minutes.
10. Move the Water Supply Valve lever to the “Tanks” position. This will prime the main tank and allow continued operation.

Recirculation

In freezing conditions, use the pressure washer pump to recirculate water through the system, to help prevent freeze-up.

1. Turn the Vacuum/Pressure Washer switch to the OFF position.

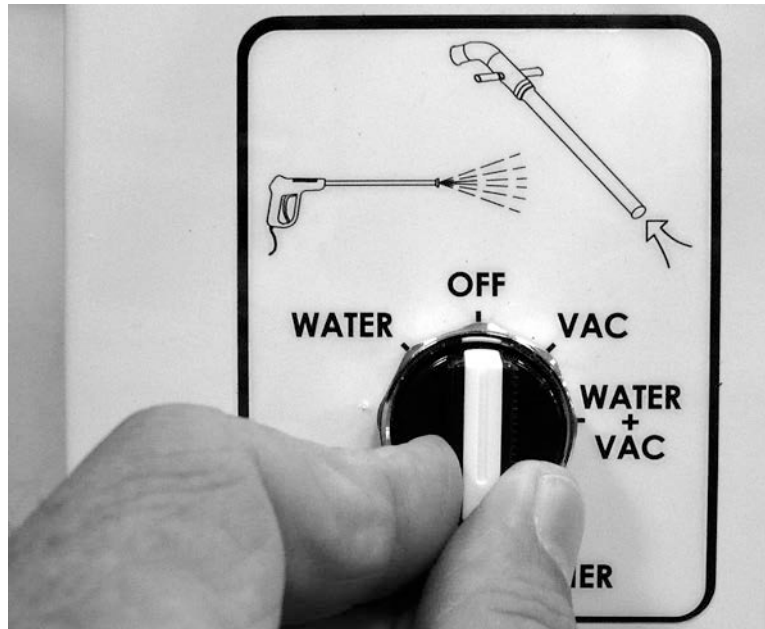
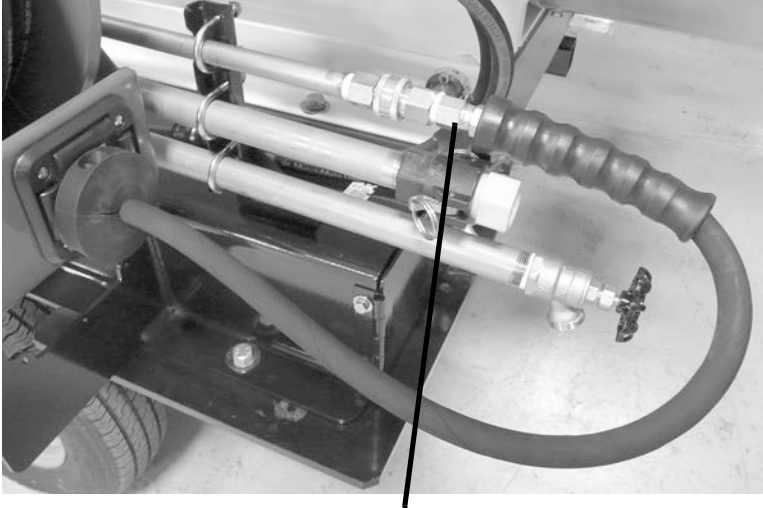

Figure 4-48. Turn the Vacuum/Pressure Washer switch OFF before you connect or disconnect the sprayer hose.

2. Connect the sprayer hose to the recirculation fitting.



Sprayer hose connected for recirculation

Figure 4-49. Connect the sprayer hose to the recirculation fitting.

- 3.** Start the engine (if not already running).
- 4.** Turn the Vacuum/Pressure Washer switch to the WATER position.

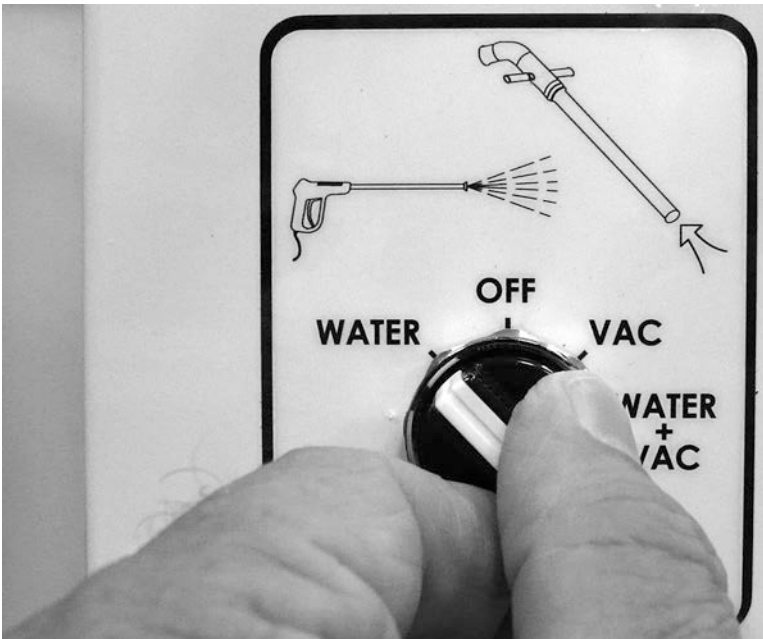

Figure 4-50. Turn the Vacuum/Pressure Washer switch to the “Water” position.

LIGHT BAR OPERATION

The light bar controller is mounted inside the control box to keep it from water damage.

1. Turn the PATTERN/FLASH CONTROL switch to the ON position.



Figure 4-51. Turn the PATTERN/FLASH CONTROL switch ON to power the light bar.

2. Use a large, flat-blade screwdriver to open the control box.



Figure 4-52. Use a screwdriver, coin, or the supplied engine key to open the control box and access the light bar control panel.

3. Access the light bar control panel inside the control box.

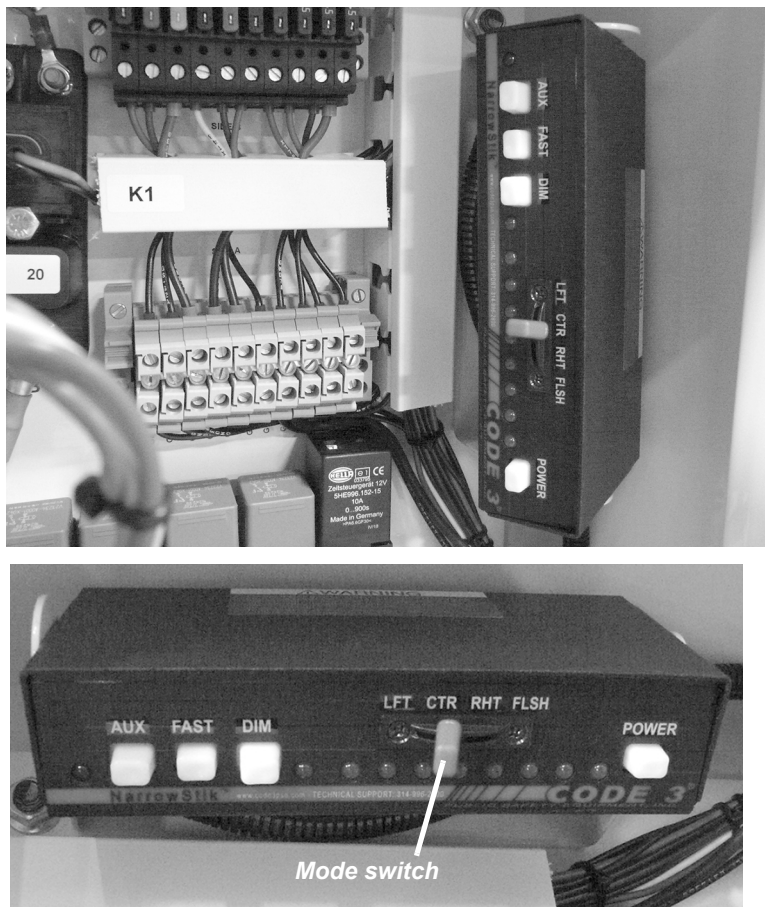

Figure 4-53. Open the control box to access the light bar control panel.

4. Press the POWER button to turn on power to the light bar.
5. If it is night, push in the DIM button for low-intensity light mode.
6. Push in the FAST button for faster flashing speed.
7. Set the mode switch to the change the light bar display, as illustrated below.

LFT	Flashing to the left
CTR	Flashing from the center out
RHT	Flashing to the right
FLSH	Flashing alternate inside/outside

8. To turn off the light bar, press the POWER button.
9. Turn the PATTERN/FLASH CONTROL switch to the OFF position.
10. Shut and secure the control box door when not operating the light bar.



NOTE

The hydraulic hoses are 45 feet long. The hose reel has a ratchet lock; when you have pulled out the desired length of hose, stop pulling when you hear the ratchet click.

AUXILIARY HYDRAULIC CIRCUIT/HOSE REEL OPERATION

1. Pull the hoses out of the hydraulic hose reel to the location of the tool you are operating.



Figure 4-54. Pull the hydraulic hose pair off the hose reel to the work location.

2. Connect the hoses to the hydraulic tool. If the tool has flow controls, make sure it is turned off.
3. Start the engine. Set the throttle so that the system pressure gauge on the front of the hydraulic tank displays the pressure you need for the tool you are operating.

TM-7 OPERATION (OPTIONAL)

This section describes how to set up the TM-7 for use. Detailed instructions on operating the TM-7 are in the *TM-7 Truck Mounted Valve Operator User's Manual*, which is provided with the TM-7.

The TM-7's hydraulic system is plumbed directly to the hydraulic tank. You do not need to connect any hoses to use the TM-7.

- 1.** Loosen the lock knob on the side of the TM-7 slide rail.
- 2.** Pull the TM-7 out to the desired operating position. Tighten the lock knob securely.



Figure 4-55. Loosen the lock knob on the side of the TM-7 slide rail, and pull the TM-7 out to the operating position as shown. Tighten the lock knob.

- 3.** Operate the TM-7 according to the instructions in the *Truck Mounted Valve Operator, Model TM-7* manual.
- 4.** When finished with the TM-7, loosen the lock knob and return it to its “parked” position. Re-tighten the lock knob.



WARNING

The water heater gets very hot. Stay away from the top vent of the heater unit when operating the heater. Contact with the heater may cause severe burns.

WATER HEATER OPERATION (OPTIONAL)

Follow the procedures below for operating the water heater. With the water heater installed, you can route the pressure washer flow through heater when you need hot water.

Notes on water heater operation:

- You can route pressure washer flow through the water heater, or bypass the heater. To bypass the heater, disconnect the water inlet hose from the heater and connect it to the bypass connector. (See schematic in drawing # 77-414-02 in Chapter 6.)
- If you are not using the water heater, it is recommended to bypass it. This helps prevent mineral and scale buildup on the inside of the water heater coils. Refer to the *Alkota Oil Water Heater Model 410 WH Operation & Service Manual* regarding Descaling.
- Do not disconnect the water heater inlet hose (from the heater fitting or the bypass fitting) while there is pressure on the washer system.
 - Turn the Vacuum/Pressure Washer switch to the OFF position.
 - Release residual water pressure through the sprayer wand.
- For equipment protection and operator safety, the pressure washer system includes a flow switch and a pressure switch. (See schematic in drawing # 77-414-02 in Chapter 6.)
 - The water heater will not operate if the flow switch does not detect adequate water flow.
 - The water heater will not operate if the pressure switch does not detect adequate water pressure.
- With sufficient flow and pressure, the water heater will switch on when its built-in thermostat calls for heat.
- In freezing weather, flush the water heater when not using it, to prevent freeze-up and damage. Refer to the *Alkota Oil Water Heater Model 410 WH Operation & Service Manual* for more specific instructions on flushing and storage.

Connecting/Bypassing the Water Heater

When you are not using the water heater, it is recommended that you bypass it.

- 1.** To route the pressure washer system through the water heater, connect the inlet hose to the inlet fitting on the water heater, and connect the outlet hose to the outlet fitting on the water heater.
- 2.** To bypass the water heater, disconnect the inlet hose and the outlet hose from the water heater fittings. Connect the two hoses directly.

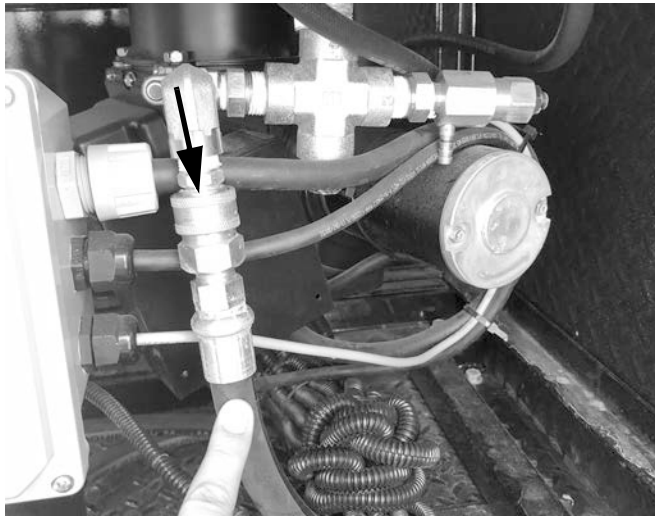

Figure 4-56. The photo shows the water heater inlet. To bypass the water heater, disconnect this hose at the location shown and connect it directly to the outlet hose (see next figure).



WARNING

Do not disconnect the water heater inlet hose (from the heater fitting or the bypass fitting) while there is pressure on the washer system. Turn off the pressure washer and release pressure in the system.



Figure 4-57. The photo shows the water heater outlet. To bypass the water heater, disconnect this hose at the location shown and connect it directly to the inlet hose (see previous figure).



WARNING

Do not use gasoline or any non-specified fuel in the water heater. Use of any other fuel could result in fire or explosion, causing serious injury or death.



NOTE

Set the engine throttle to low speed before turning on the pressure washer or vacuum blower.

Starting and Running the Water Heater

- 1.** Fill the heater's fuel tank. Use only kerosene or diesel (#1 or #2) fuel.
- 2.** Start the skid system engine and run at low to medium throttle.
- 3.** At the curbside control panel, turn the Vacuum/Pressure Washer switch to the WATER position.

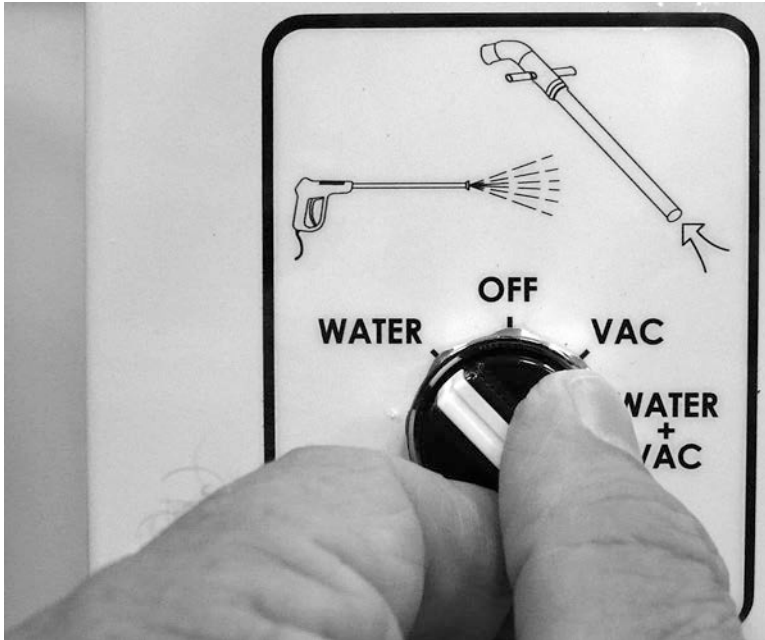

Figure 4-58. Turn the Vacuum/Pressure Washer switch to the WATER position.

4. On the water heater control box, set the desired temperature on the thermostat.
5. Turn the water heater switch to the on position. The red **POWER** indicator will light.

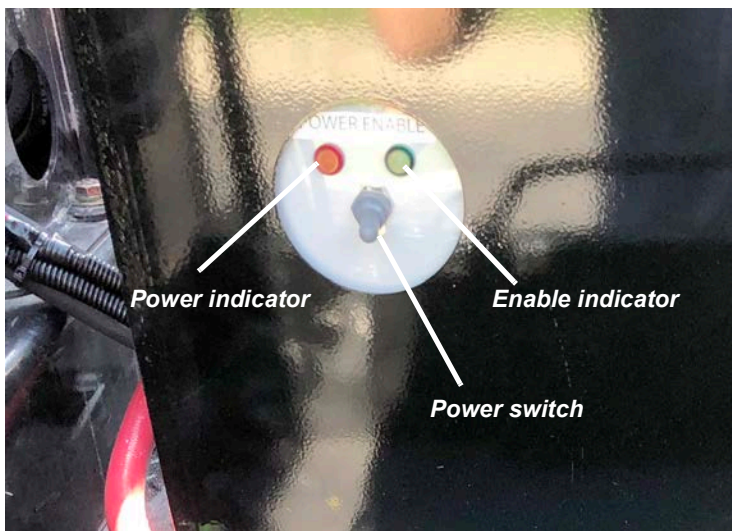

Figure 4-59. The photo shows the water heater control panel.



NOTE

There must be sufficient water flow and pressure for the water heater to operate. The green **ENABLE** indicator will light when flow and pressure are sufficient.



NOTE

You must have the engine running and the Vacuum/Pressure Washer switch set to WATER.

- The POWER indicator lights when the water heater is powered on.
- The green ENABLE indicator lights when there is sufficient water flow and pressure, and the burner is on.

- 6.** The heater will heat the water to the temperature on the thermostat. The burner will then cycle on and off as necessary to maintain that temperature.
- 7.** To turn the water heater off, turn the power switch on the water heater control panel off.

Spraying Hot Water

See “Pressure Washer Operation” in this chapter for instructions on operating the sprayer.

- 1.** Operate the sprayer as usual. It may take a few seconds for hot water to reach the spray wand.

When you are using the system in low-temperature (freezing) conditions, you should operate the pressure washer pump with the sprayer hose connected to the recirculation fitting. See “Recirculation” on page 76.

Chapter 5

Maintenance

LUBRICATION AND FLUID MAINTENANCE

Mechanical Grease Fittings

Lubricate the fittings on the following components:

- spoils tank dump pivot
- spoils tank dump slide
- spoils tank door.

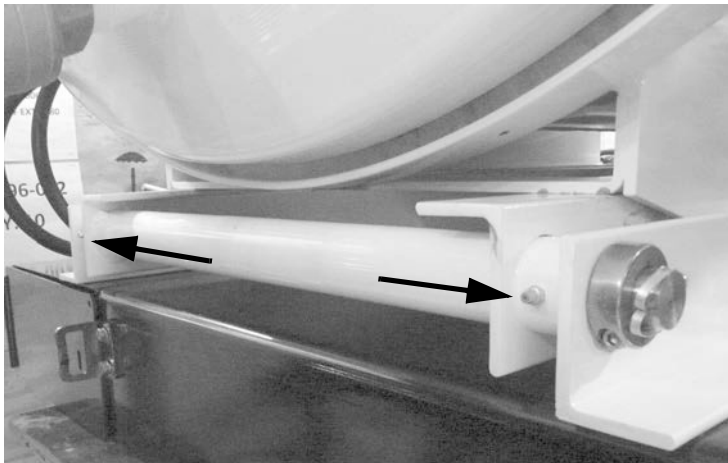

Figure 5-1. Apply grease to the dump pivot at the 2 fittings (one each side).

In This Chapter

LUBRICATION AND FLUID MAINTENANCE

REPLACING FUSES

SERVICING THE DRIVE BELTS

ADJUSTING THE TANK LATCHES

VALVE OPERATORS

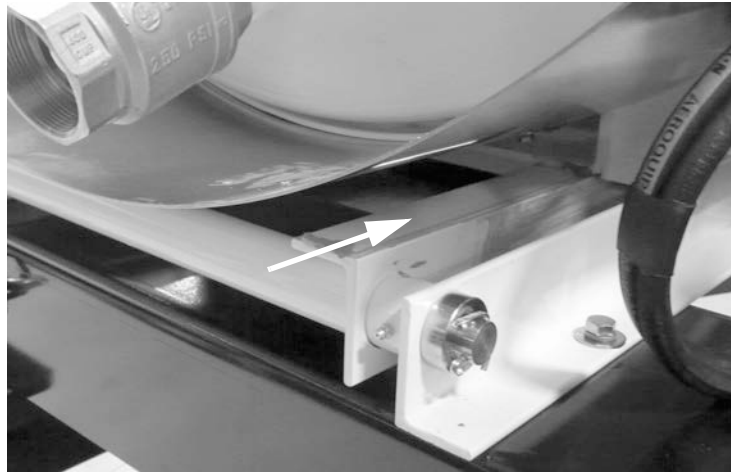

Figure 5-2. Apply grease directly onto the dump slide rails (both sides). Move the tank to the dump position to grease the full length of the slide rails.



Figure 5-3. Apply grease to the tank door hinges at the 2 fittings (one each side).

Pressure Washer Pump

The pressure washer pump is a General Pump model TX1512S17.

- Change the pump crankcase oil after an initial 50-hour break-in period.
- After break-in period, change the oil every 3 months or 500 hours of operation.
- Use General Pump Series 100 oil (30 weight) in the pressure washer pump.

Blower

The vacuum blower is a Howden Roots Universal URAI blower. The Howden *Installation, Operation, and Maintenance Manual* supplied with the blower provides detailed lubrication guidelines. Read and refer to the blower manual for full maintenance instructions.

- Change the oil after an initial 100-hour break-in period.
- After break-in period, change the oil according to its life expectancy, based on operating temperature:
 - 6000 hours at less than 180° F.
 - For every 15° F above 180° F, oil life expectancy is reduced by half.
 - Assume oil operating temperature is 80% of discharge air temperature (Fahrenheit).
- Use Roots Synthetic Oil part no. 813-106-220 (ISO viscosity no. 220) for operation from 32°-90° F.
- **DO NOT** use Mobil SHC synthetic oils.

For full maintenance information, see the Howden manual.

Lubricating the Blower

To prevent corrosion, lubricate the blower at the end of the day with a spray lubricant such as WD-40. Apply the spray through the port on the powerpack.

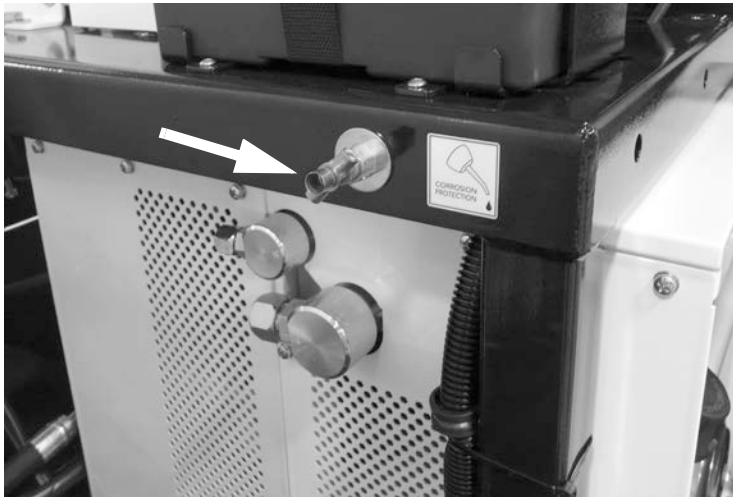

Figure 5-4. There is a blower lubrication port on the powerpack frame.

IMPORTANT: Empty the spoils tank before lubricating the blower, to reduce recirculation of moisture and debris.

- 1.** Start the engine and run it at medium throttle.
- 2.** At the curbside control panel, turn the Vacuum/Pressure Washer switch to the VAC position. The vacuum blower will engage.

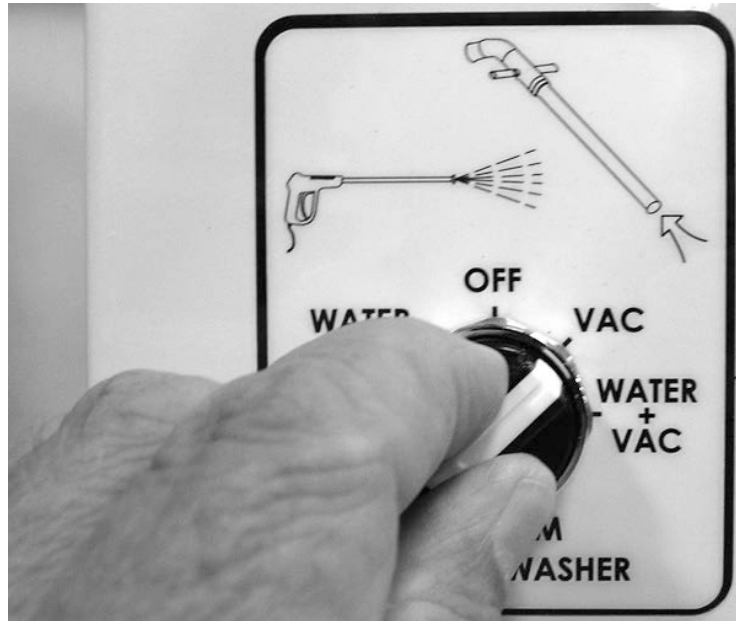

Figure 5-5. Turn on the vacuum to lubricate the blower.

- 3.** Turn the blower lubrication port fitting **clockwise** to open the port.



Figure 5-6. Open the blower lubrication port.

4. Spray lubricant (WD-40 or equivalent) into the port for 15-30 seconds while the blower is running.
5. Turn the blower lubrication port fitting **counter-clockwise** to close the port.



Figure 5-7. Close the blower lubrication port after spraying the lubricant.

6. At the curbside control panel, turn the Vacuum/Pressure Washer switch to the OFF position.



CAUTION

Make sure the lubrication port is closed after you finish the lubrication.

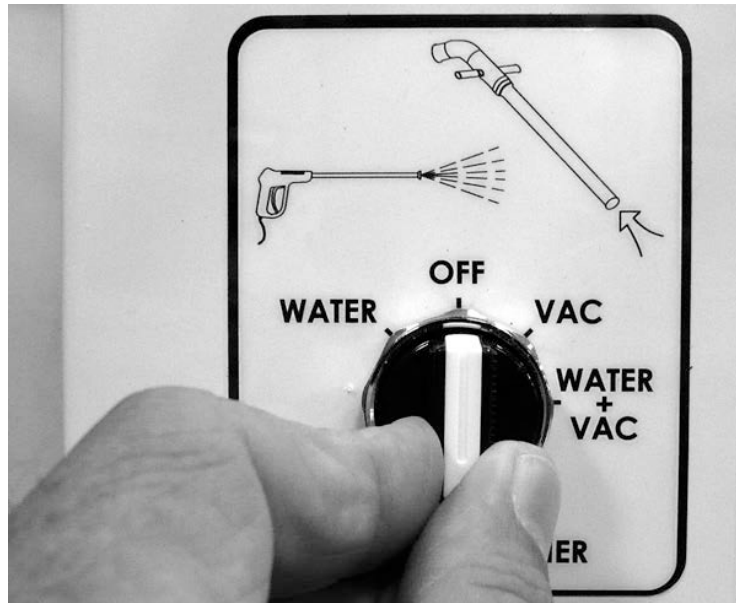

Figure 5-8. Turn the Vacuum/Pressure Washer switch to OFF after lubricating the blower.

Engine

Diesel Engine

- Change the engine oil after the initial 50 hours of operation, and every 200 hours of operation after that.
- Change the oil filter cartridge after the initial 50 hours of operation, and every 200 hours of operation after that.

Refer to the *Operator's Manual* provided with the Kubota engine for instructions on the oil changing procedure, and for full maintenance information.

Gas Engine

- Change the engine oil every 100 hours of operation, or annually.
- Change the oil filter every 200 hours of operation.

Refer to the *Service Manual* provided with the Kohler engine for instructions on the oil changing procedure, and for full maintenance information.

REPLACING FUSES

The fuse block is inside the curbside control panel.

1. Using a flat-blade screwdriver, open the control panel door.



Figure 5-9. To access the fuse block, open the front of the curbside control panel.

2. There is a fuse reference chart on the inside of the control panel door. Identify the blown fuse in the fuse block. Pull out the fuse and press in a new one. Make sure the new fuse is the correct amperage rating.

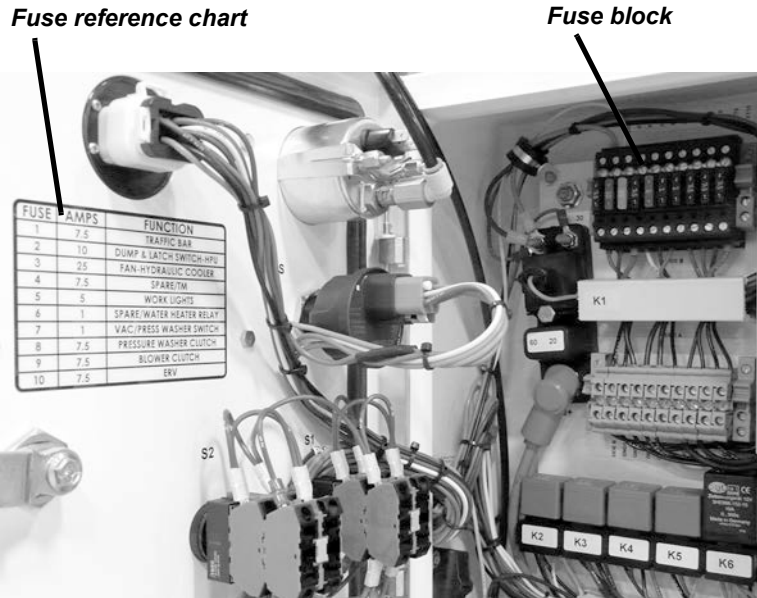

Figure 5-10. Identify the blown fuse in the fuse block. There is a fuse reference chart on the inside of the control panel door.

3. Close the control panel door and secure the latch with the screwdriver.

SERVICING THE DRIVE BELTS

This section describes how to check and replace the belts that drive the sprayer pump and vacuum blower. There are two belts driving each machine. The procedures include instructions on tightening the belts; if the belts are in good condition but are loose, tighten them rather than replacing them.

Check for cracks, tears, worn surfaces, or signs of overheating when you inspect the belts. Replace any belt that is damaged.

Vacuum Blower Belts

1. Remove the screws securing the blower belt cover. Remove the cover.



NOTE

It is easier to access the belts if you first move the spoils tank out to the dump position.

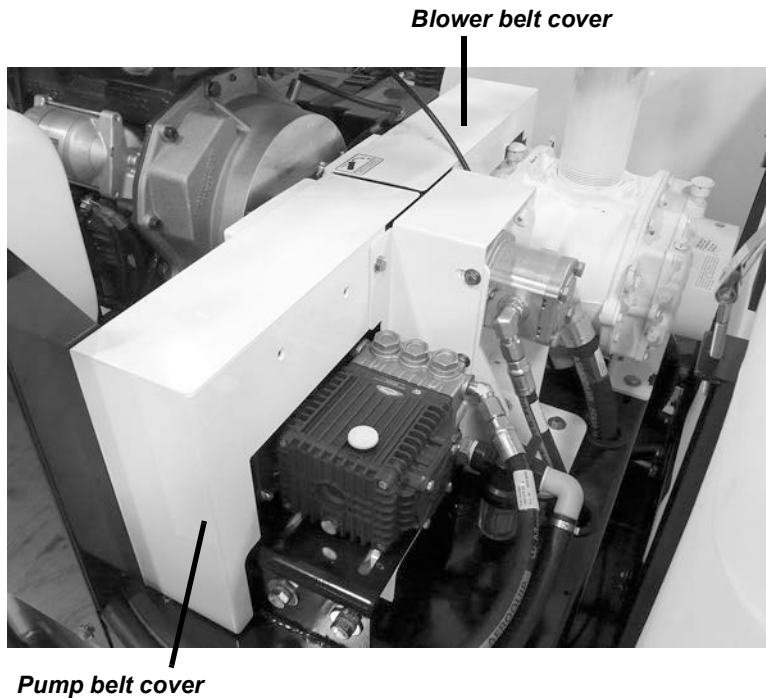

Figure 5-11. Remove the screws securing the blower belt cover to take the cover off and access the belts.

- 2.** Inspect the belts for any damage. Check the tension on the belts.

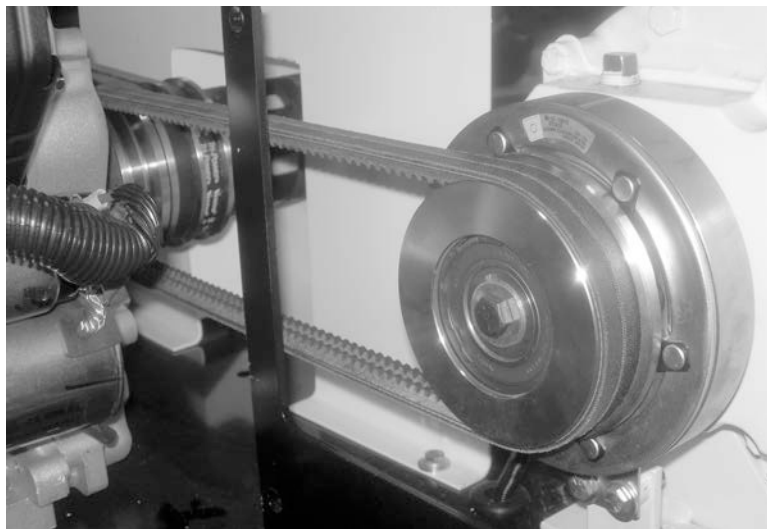

Figure 5-12. Inspect the blower belts for damage and correct tension.

- 3.** If you need to replace one or both belts, loosen the tension all the way using the tension screws:

- Loosen the 4 position locking screws on the blower mounting plate.
- Turn the tension screws counter-clockwise all the way to full loosen the belts.

Position locking screws
(2 each side)

Belt tension screws

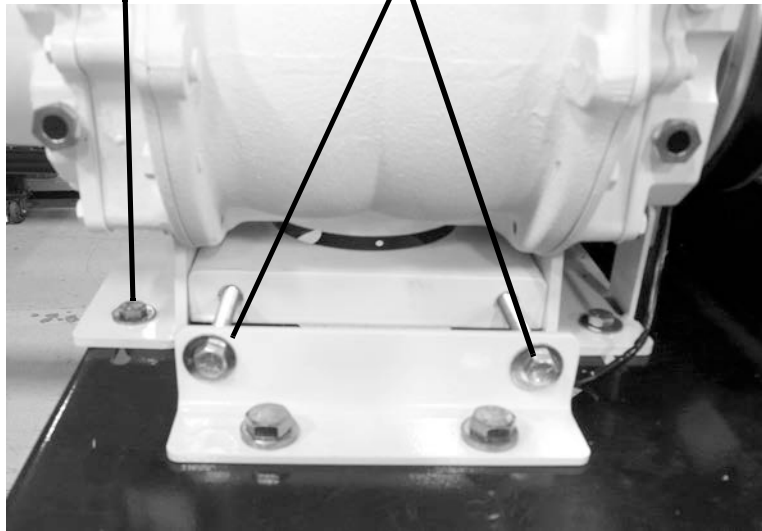

Figure 5-13. Use the tension screws on the blower mounting plate to loosen and tighten the blower belts.



NOTE

Turn both tensioning screws the same number of turns to keep the blower square with the drive system.

4. Slip the belt you are replacing off the pulleys, and replace it with the new belt.
5. Tighten the blower belt tensioning screws until the belts are tight on the pulleys. You should be able to deflect the belts no more than 1/2" (13 mm) by pressing on them with your thumb halfway between the pulleys.
6. Replace the blower belt cover and secure it with the screws.



NOTE

It is easier to access the belts if you first move the spoils tank out to the dump position.

Sprayer Pump Belts

1. Remove the screws holding the sprayer pump belt cover. Remove the cover.

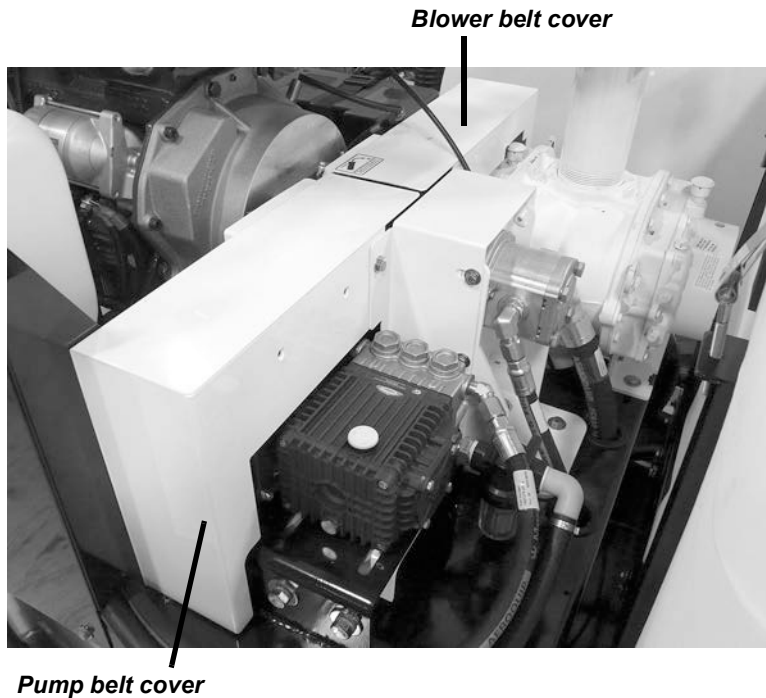

Figure 5-14. Remove the screws securing the pump belt cover to take the cover off and access the belts.

- 2.** Inspect the belts for any damage. Check the tension on the belts.

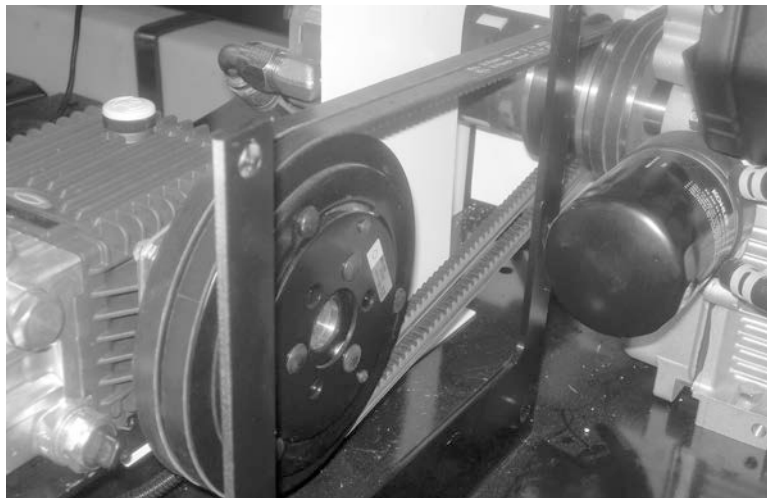

Figure 5-15. Inspect the sprayer pump belts for damage and correct tension.

- 3.** If you need to replace one or both belts, loosen the tension all the way using the tension screws:

- Loosen the 4 position locking screws beneath the pump mounting plate.
- Turn the tension screws counter-clockwise all the way to full loosen the belts.

Belt tension screws

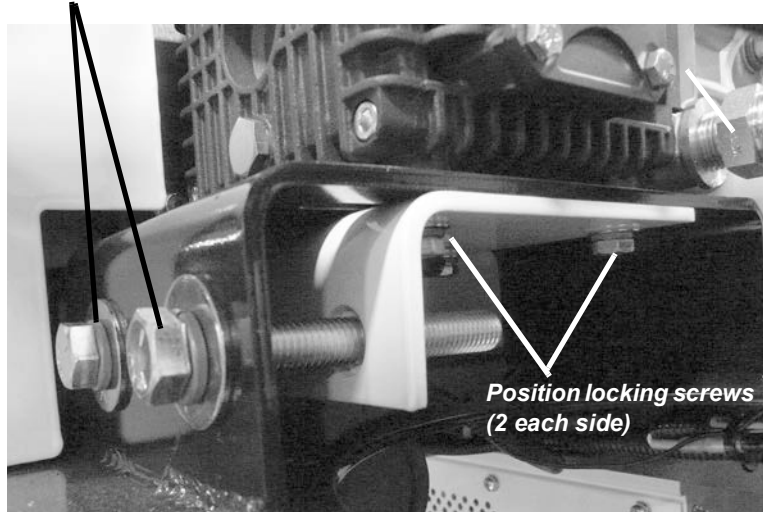

Figure 5-16. Use the tension screws on the pump mounting plate to loosen and tighten the blower belts.

4. Slip the belt you are replacing off the pulleys, and replace it with the new belt.
5. Tighten the sprayer pump belt tensioning screws until the belts are tight on the pulleys. You should be able to deflect the belts no more than 1/2" (13 mm) by pressing on them with your thumb halfway between the pulleys.
6. Re-tighten the position locking screws
7. Replace the sprayer pump belt cover. Insert and tighten the screws.



NOTE

Turn both tensioning screws the same number of turns to keep the sprayer pump square with the drive system.

ADJUSTING THE TANK LATCHES

You can adjust the clearance between the spoils tank door and the seal. If the door is leaking, you will need to tighten the latch pin adjustment. If the latch won't completely engage, you will need to loosen the latch pin adjustment.

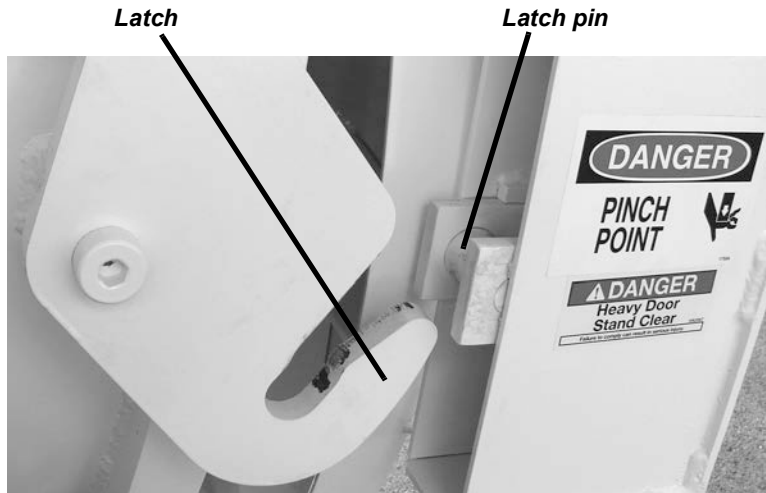

Figure 5-17. When you close the tank door, the latch engages behind the latch pin to clamp the door shut.

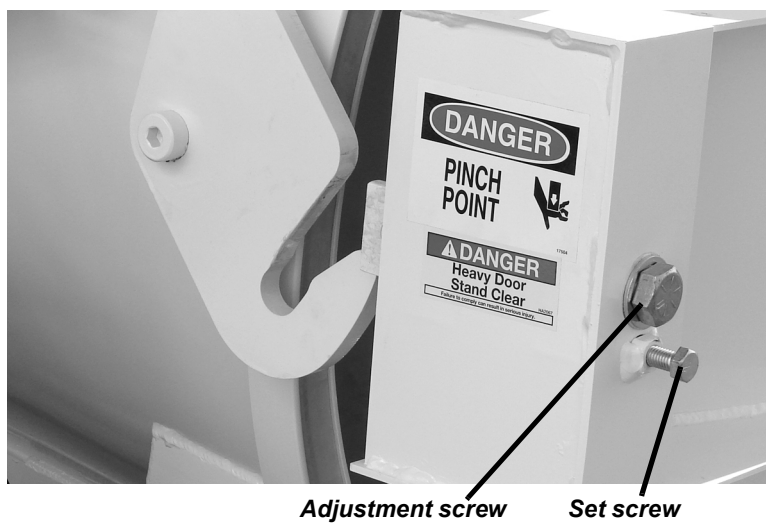

Figure 5-18. The front of the latch cover has screws for adjusting the latch.

Perform the following procedure for both sides of the tank door.

1. At the control panel, turn the Latch Switch to the OPEN position and hold it until the latch is fully released.



NOTE

The power switch on the engine must be in the ON position to operate the door latch.



Figure 5-19. Turn the Latch Switch to the OPEN position and hold it until the latch fully opens.

2. Turn the set screw on the front of the latch cover several turns counter-clockwise to loosen it.



Figure 5-20. Turn the set screw counter-clockwise to loosen it.



NOTE

Adjust the screw no more than one turn at a time. Operate the latch to check it after each turn.

3. To **tighten** the latch, turn the adjustment screw **clockwise**.



Figure 5-21. Turn the adjustment screw clockwise to tighten the latch.

- 4.** To **loosen** the latch, turn the adjustment screw **counter-clockwise**.



Figure 5-22. Turn the adjustment screw counter-clockwise to loosen the latch.

- 5.** Securely tighten the set screw when you have finished the adjustment.

VALVE OPERATORS

ERV-750

Refer to the maintenance instructions in the *ERV-750 Extended Reach Valve Operator User's Manual*, provided with the valve maintenance system.

TM-7

Refer to the maintenance instructions in the *TM-7 Truck Mounted Valve Operator User's Manual*, provided with the valve maintenance system (if equipped with the optional TM-7).

COLD WEATHER PREPARATION AND SERVICE

Use the following procedure to prepare the VMS pressure washer system for operation or storage in freezing weather.

If you use the pressure washer system in potentially freezing weather, drain it after operating and antifreeze the system again, using this procedure.

For operation of the pressure washer system in freezing temperatures, see “Recirculation” on page 76.

- 1.** Open the drain valve on the pressure washer water tank and allow the tank to empty.
- 2.** Set the water source selector valve set to Main Tank. Start the engine and run the water system at idle until water stops flowing back to the main tank through the recirculation circuit.
 - There is a flow switch which might shut the pump off before it's completely empty. Switch the pump off/on several times to make sure all water is removed.
- 3.** Fill the antifreeze/prime tank with RV antifreeze—approximately 3 gallons.
- 4.** Flip the water source valve to the antifreeze tank.

- 5.** Start the engine and run the water system at idle until you see antifreeze running at full concentration in the main water tank from the recirculation circuit.
- 6.** Shut off the engine
- 7.** Close main water tank drain valve.
 - If you close this too soon, you will trap fresh water in the low point drain.
- 8.** If your system has the optional water heater, flush the water heater to prevent freeze-up and damage. Refer to the *Alkota Oil Water Heater Model 410 WH Operation & Service Manual* for more specific instructions on flushing and storage.



Chapter 6

Parts List and Ordering Information

ORDERING INFORMATION

To place an order, request service, or get more detailed information on any E.H. Wachs Company products, call us at one of the following numbers:

U.S. 800-323-8185
International: 847-537-8800

You can also visit our Web site at:

www.ehwachs.com

Ordering Replacement Parts

When ordering parts, refer to the parts lists in this chapter. Please provide the part description and part number for all parts you are ordering.

Repair Information

Please call us for an authorization number before returning any equipment for repair or factory service. We will advise you of shipping and handling. When you send the equipment, please include the following information:

- Your name/company name
- Your address
- Your phone number

In This Chapter

ORDERING INFORMATION

DRAWINGS AND PARTS LISTS

- A description of the problem or the work to be done.

Before we perform any repair, we will estimate the work and inform you of the cost and the time to complete it.

Warranty Information

Enclosed with the manual is a warranty card. Please fill out the registration card and return to E.H. Wachs Company. Retain the owner's registration record and warranty card for your information.

Return Goods Address

Return equipment for repair to the following address.

E.H. Wachs
600 Knightsbridge Parkway
Lincolnshire, Illinois 60069 USA

DRAWINGS AND PARTS LISTS

The drawings on the following pages illustrate the components of the VMS systems (both diesel and gas engine configurations), and include parts lists for ordering spare or replacement parts.

REV.	DESCRIPTION	DATE	APP.
A	NEW RELEASE (ECO 171)	9/12/2019	MMW

REVISION HISTORY

1. MATERIAL PER COMPONENT

2. APPROX WEIGHT: SEE WEIGHT AND CENTER OF GRAVITY TABLE

3. APPROX WEIGHT: SEE WEIGHT AND CENTER OF GRAVITY TABLE

4. LEGEND USED FOR CONTINUATION OF EXPLODED LINE

5. SEE SHEET 13 AND 14 FOR ELECTRIC SCHEMATIC.

6. SEE SHEET 16 FOR PRESSURE WASHER SYSTEM SCHEMATIC.

7. SEE SHEET 16 FOR PRESSURE WASHER SYSTEM SCHEMATIC.

8. WEIGHT OF SPOIL WITH FULL SPOILS AND FULL WATER.

9. CUSTOMER AND UPFITTER ARE RESPONSIBLE FOR NOT OVERTIGHTENING THE VEHICLE ABOVE ITS GROSS VEHICLE WEIGHT RATING (GVWR). ALL PASSENGERS, EQUIPMENT, FUEL, VACUUM SPOILS, WATER, AND CARGO MUST BE ACCOUNTED FOR. UPFITTERS SHALL SUPPLY A LABEL WITH THE GVWR AND THE LOCATION OF THE GVWR LABEL ON THE DRIVER'S DOOR JAMB. CUSTOMERS SHALL NOT LOAD THE VEHICLE ABOVE ITS GVWR. SPOILS AND WATER WEIGHTS FOR THE SUPPLIED VMS CONFIGURATION ARE PROVIDED ON THE VMS. SEE SHEET 6 FOR LABEL INFORMATION AND PLACEMENT.

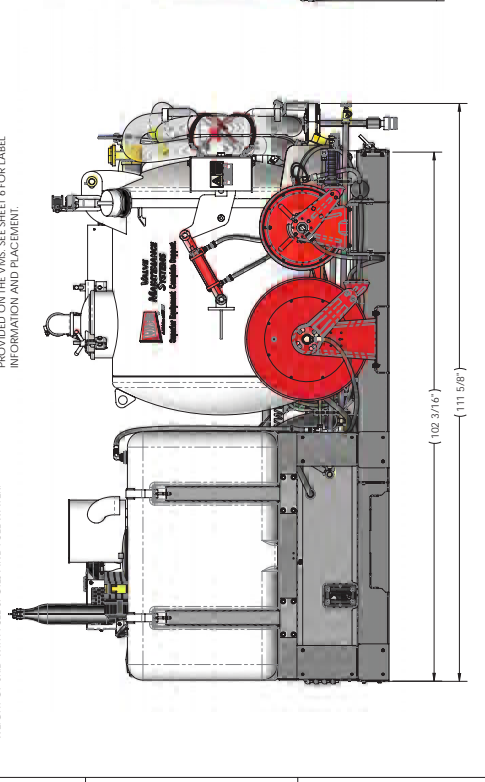
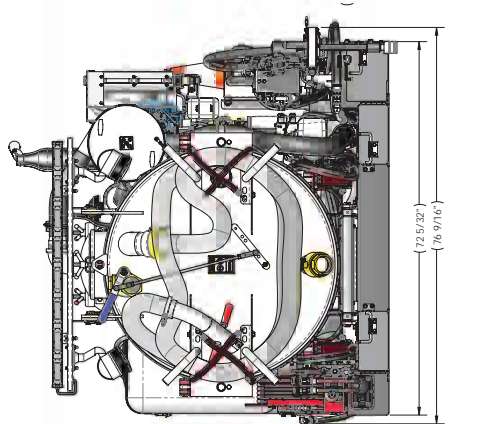
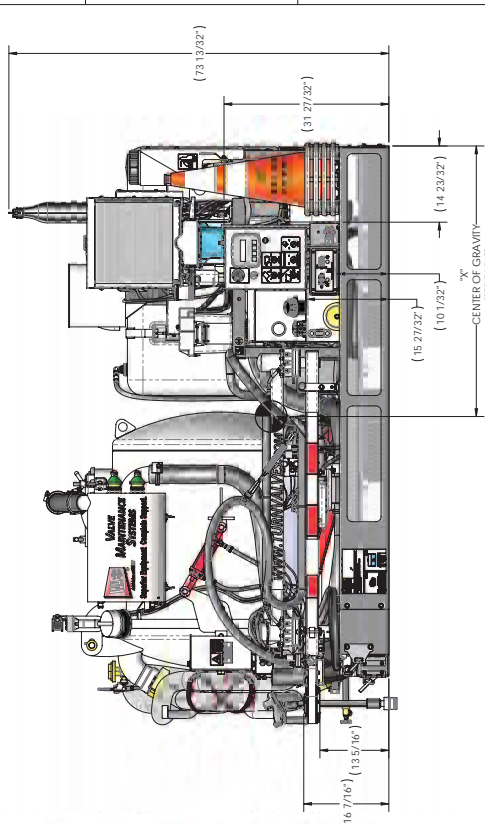

250 GAL SPOILS TANK	100 GAL WATER TANK "X" (INCHES) APPROX	WEIGHT APPROX (LBS)
EMPTY	51.5/8"	4194
FULL (WATER)	47"	5028
EMPTY	59.3/4"	6182
FULL (WATER)	55.3/8"	7026

HYDRAULIC RESERVOIR FULL FUEL TANK FULL ANTI-FREEZE TANK FULL

SEE NOTE 9

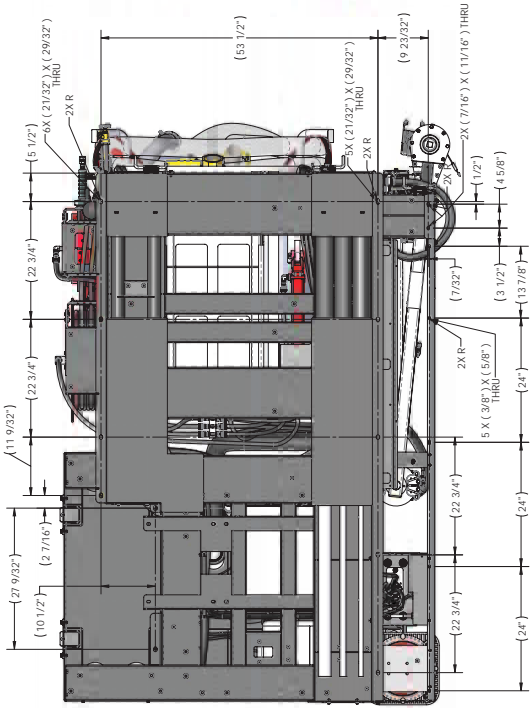
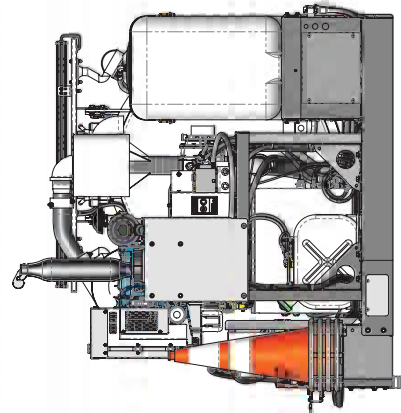

MOUNTING HOLES
 11X 1/2" GRADE 8 BOLTS &
 7X 3/8" X 5/8" NUTS
 REQUIRED FOR MOUNTING.
 SEE NOTE 8

E.H. WACHS
 600 E. Highway 100, Suite 100
 Phoenix, AZ 85026
 www.ehwachs.com

REV.	DESCRIPTION	DATE	APP.
A	NEW RELEASE (ECO 171)	9/12/2019	MMW

STANDARD Lx D (SEEL - VMS) (RHS)
 77-000-54

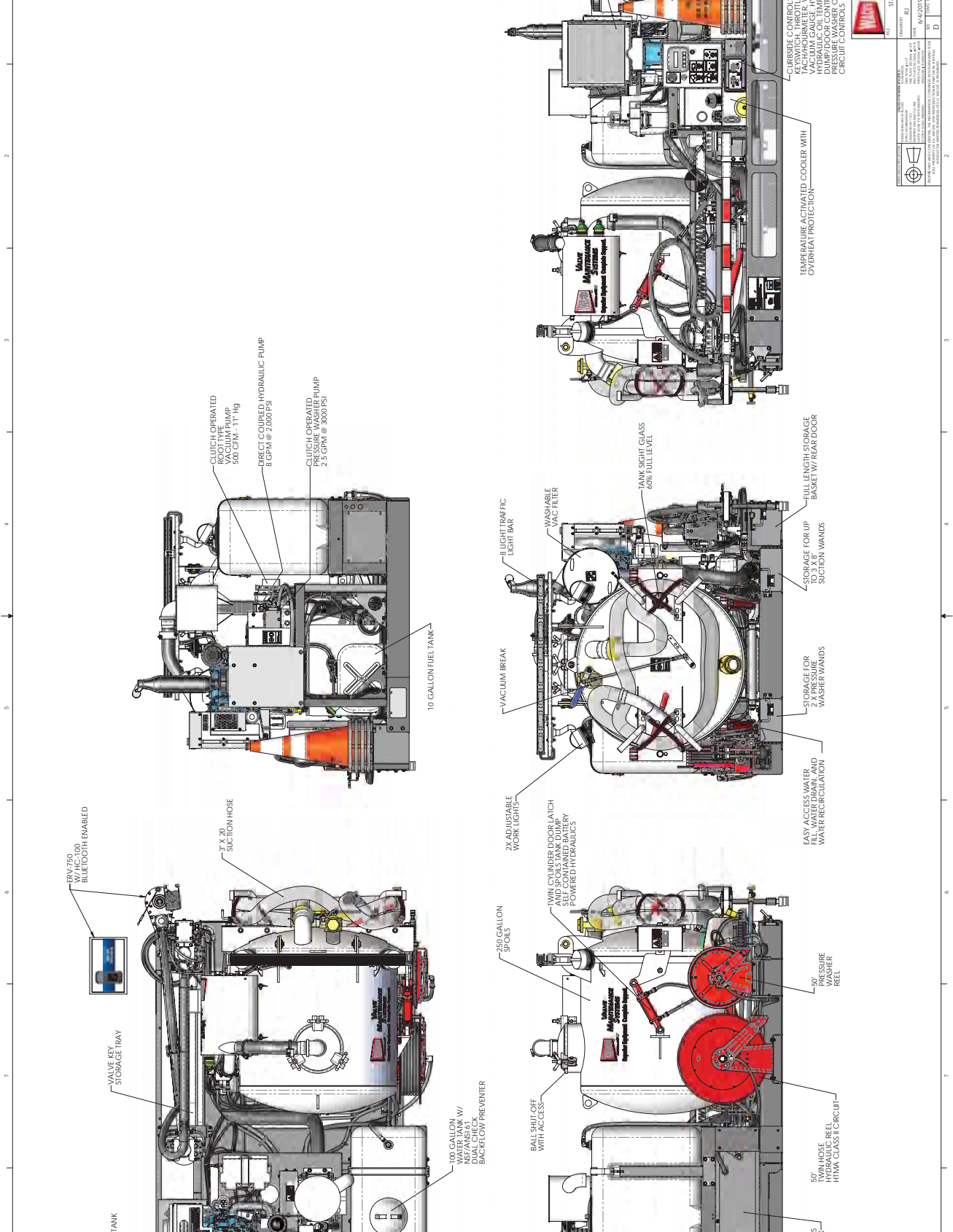

E.H. WACHS
 600 KENNEDY BOULEVARD
 WILSONVILLE, OR 97150
 WWW.EHWACHS.COM

STANDARD Lx D (SEEL - VMS) (R9)	132"	132"
DATE	01/22/2019	2 OF 17
REV	02/28/19	2 OF 17
REV	02/01/20	2 OF 17
REV	02/01/20	2 OF 17

77-000-54

ITEM NO.	PART NUMBER	DESCRIPTION	QTY.	ESTIMATE LENGTH	ITEM NO.	PART NUMBER	DESCRIPTION	QTY.	ESTIMATE LENGTH
1	68-153-11	HANDLE, CLEVIS ROD	1		55	77-299-46	LABEL, CVWR WARNING	1	
2	68-158-16	HOSE CLAMP, CRIMP, 23.9 - 27.1MM	5		56	77-290-00	WELDMENT, VMS SKID RH CONTROLS	1	
3	68-168-57	HOSE CLAMP, 3" SPIRAL, CLOCWISE	2		57	77-291-01	WELDMENT, CONE HOLDER	1	
4	68-168-03	HOSE, 3" VACUUM, BLACK	1	(6.75FT)	58	77-291-28	28" TRAFFIC CONE	4	
5	68-195-50	HOSE REEL, REEL/CATCH, (3/8" X 30') BOTTOM WIND	1		59	77-292-12	151 5/16" HOSE ASSEMBLY, -08 FJ X -08 FJ X -08 HOSE	1	
6	68-282-50	G.D. PLUG, 3/8" X 3/8" NPTF	1		60	77-292-13	43 13/16" HOSE ASSEMBLY, -08 FJ X -08 FJ X -08 HOSE	1	
7	68-283-00	HOSE, 3/4" LP LOCK ON	3	(8 1/2') (10 1/2') (8FT)	61	77-312-20	3" X 20' CLEAR SUCTION HOSE ASSEMBLY	1	
8	68-286-00	STRIP, EPDM ADHESIVE BACKED FOAM RUBBER, 2" W X 1/4" THK	2	2K (9')	62	77-406-00	WASH DOWN WAND	1	
9	68-286-00	STRIP, EPDM ADHESIVE BACKED FOAM RUBBER, 2" W X 1/4" THK	2	2K (20 1/2')	63	77-408-01	PRESSURE WASHER WAND, WORKING NOZZLE	1	
10	68-242-51	DRAIN VALVE, 3/4" NPT FEMALE INLET X 3/4" MIGHT OUTLET	2		64	77-413-04	ROLLER ASSEMBLY	3	
11	68-243-20	ADAPTER, 3/4" NPT M X 3/4" HOSE BARB - NYLON	1		65	77-413-05	HYDRAULIC HOSE REEL KIT, BOTTOM ROLLER	1	
12	68-243-30	ELBOW, 3/4" NPT M X 3/4" HOSE BARB - NYLON	3		66	77-420-00	LIGHT BAR KIT	1	
13	68-243-70	HOSE TO CAM LEVER ADAPTER, 3/4" CAM M X MIGHT	1		67	77-431-02-00	ASSEMBLY, 250 GAL. SPOILS TANK	1	
14	68-243-71	CAM LEVER SOCKET, 3/4" X 3/4" NPTF	1		68	77-520-03-29	WIRE HARNESS, SKID POWER PACK	1	
15	68-243-80	ADAPTER, 3/4" BARB X 3/4" NPTF	1		69	79-404-00	ERV-750 FOR VMS KIT	1	
16	68-247-01	SNAP BUSHING, 1.38 ID X 1.75 HOLE X 1.25 PANEL	1		70	79-422-01	HC-100 - VIALS CONTROLLER KIT - N AMER	1	
17	68-420-02	WAND WELDMENT, 7/8" X 6", 3" HOSE	1		71	90-045-04	NUT, 10-24 NYLOCK	18	
18	68-420-03	WAND WELDMENT, 1-1/4" X 8", 3" HOSE	1		72	90-051-07	HHCS, 1/4-20 X 3/4 GRADE 5 FN	12	
19	68-420-04	WAND WELDMENT, 2-1/2" X 8", 3" HOSE	1		73	90-051-10	HHCS, 1/4-20 X 1	12	
20	77-162-63	100 GALLON WATER TANK ASSEMBLY	1		74	90-055-01	NUT, 1/4-20 HEX	2	
21	77-175-11	BIUMPER, PUSH IN 1/4" HOLE	6		75	90-055-18	NUT, 1/4-20 ACCORN	13	
22	77-289-02	CLAMP, 3.5" OD	1		76	90-055-52	WASHER, 1/4 SPLIT RING	25	
23	77-209-04	U-BOLT, ZINC-PLATED STEEL, 1/4"-20, 1-1/8" ID, 2" HEIGHT	6		77	90-055-53	WASHER, FLAT, 1/4	25	
24	77-235-94	LATCH CATCH	1		78	90-061-07	NUT, 5/16-18 X 3/4	6	
25	77-235-95	LATCH ASSY, RH	1		79	90-066-01	NUT, 5/16-18 HEX GRADE 8	6	
26	77-236-95	LATCH ASSY, LH	2		80	90-065-51	WASHER, 5/16 SPLIT RING	6	
27	77-260-13	KIT, DIESEL SKID POWER PACK	1		81	90-065-52	WASHER, 5/16 FLAT	6	
28	77-276-11	DOUBLE CHECK VALVE, 3/4" NPTF X 3/4" NPTF	1	(2.3/4')	82	90-071-10	HHCS, 3/8-16 X 1	48	
29	77-277-50	PVC EDGE RIM, 0.095 TO 0.190 EDGE THICKNESS	1		83	90-071-20	HHCS, 3/8-16 X 2 GR 5 ZN	4	
30	77-290-01	WATER TANK BASE WELDMENT	1		84	90-076-01	NUT, 3/8-16 HEX GR 5 ZN	3	
31	77-290-02	WELDMNT, WATER TANK STAKE	4		85	90-075-05	NUT, 3/8-16 NYLOCK GR 5 ZN	4	
32	77-290-03	HOSE ROLLER GUIDE BRACKET	1		86	90-075-52	WASHER, 3/8 SPLIT RING	4	
33	77-290-04	WELDMENT, BASKET SOE	1		87	90-075-53	WASHER, 3/8 FLAT	52	
34	77-290-05	WELDMENT LATCH BRACKET	1		88	90-078-84	ADAPTER, -8 (3/4" - 16) MUI X 3/8" NPT F 90	1	
35	77-290-06	WAND HOLDER WELDMENT	1		89	90-091-12	HHCS, 1/2-13 X 1-1/4 GRADE 8	14	
36	77-290-07	PRESSURE WASHER WAND HOLDER WELDMENT	1		90	90-095-15	NUT, 1/2"-13 HEX GR 8 YELLOW ZINC	2	
37	77-290-08	WELDMENT, DOOR SKID	2		91	90-095-52	WASHER, 1/2 FLAT	14	
38	77-290-09	WELDMENT, BASKET DOOR	1		92	90-095-58	WASHER, 1/2 SPLIT RING	14	
39	77-290-11	WELDMENT, SUPPORT BRACKET	1		93	90-140-07	SHCS, 10-24 X 3/4 SS18-8	18	
40	77-290-12	PIPE SUPPORT BRACKET	2		94	90-218-15	TEE, 3/4 NPT POLY SCH 80	1	
41	77-290-13	PIPE SUPPORT	2		95	90-218-18	NIPPLE, 3/4 NPT, 1 3/8 PVC SCH 80	1	
42	77-290-15	BASKET BACK PANEL	1		96	90-903-10	CUSHIONED LOOP CLAMP, 1"	1	
43	77-290-16	COVER PLATE	2		97	90-905-15	CUSHIONED LOOP CLAMP, 1 1/2"	5	
44	77-290-17	COVER PLATE	1		98	90-903-20	CUSHIONED LOOP CLAMP, 2"	3	
45	77-290-18	COVER PLATE	1		99	90-903-25	CUSHIONED LOOP CLAMP, 3/4"	3	
46	77-290-20	HOSE BRACKET	1		100	90-903-75	CUSHIONED LOOP CLAMP, 3/4"	1	
47	77-290-21	BACK COVER PANEL	1		101	90-106-58	HHCS, 1/4-20 X 5/8" GR5 ZN	28	
48	77-290-22	SIDE COVER PANEL	1		102	910-8-8-CT1K-S	ELBOW, 1/2" M NPT X 8 M JIC (9/4"-16)	2	
49	77-290-24	WELDMENT, KEY BOX	1		103	90-15836K10	CLEVIS ROD END, 1/2-13'	2	
50	77-290-28	STRAP, WATER TANK	2		104	90-8516K696	THREADED ROD, 1/2-13" X 24"	1	
51	77-290-29	STAINLESS STEEL PIPE, 3/4" SCH 40	2		105	90-913327A168	BOLT, SHOULDER, 1/2 X 5/16 X SS	1	
52	77-290-30	STAINLESS STEEL PIPE, 3/8" SCH 40	1						
53	77-290-31	LATCH CATCH	2						
54	77-290-44	LABEL, 100 GAL WATER TANK	1						

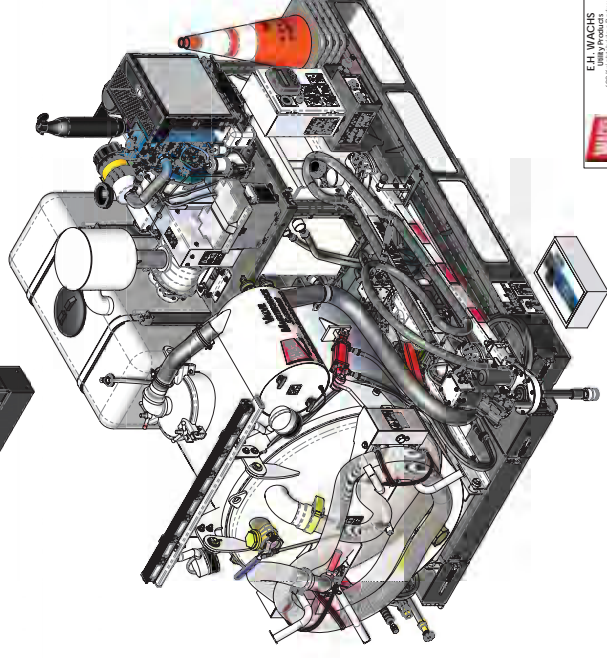
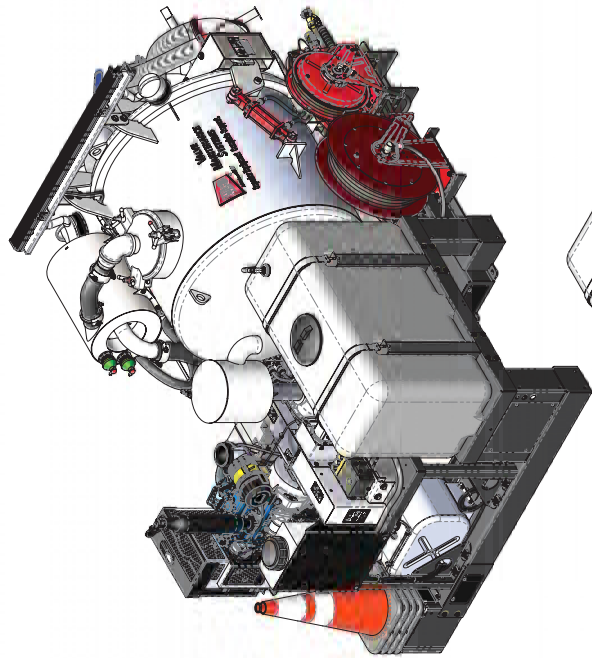

E.H. WACHS
605 KRYPTON DRIVE
SANDERSVILLE, GA 31081
WWW.EHWACHS.COM

REV.	STANDARD LX (DIESEL - VMS) (RH)	SCALE	1:12
DATE	01/22/2019	HEET	3/12
DATE	01/22/2019	HEET	2/07/17
DATE	01/22/2019	HEET	2/07/17
DATE	01/22/2019	HEET	2/07/17

77-000-54

E.H. WACHS
605 KRYPTON DRIVE
SANDERSVILLE, GA 31081
WWW.EHWACHS.COM

REV.	STANDARD LX (DIESEL - VMS) (RH)	SCALE	1:12
DATE	01/22/2019	HEET	3/12
DATE	01/22/2019	HEET	2/07/17
DATE	01/22/2019	HEET	2/07/17
DATE	01/22/2019	HEET	2/07/17

77-000-54

E.H. WACHS
605 KRYPTON DRIVE
SANDERSVILLE, GA 31081
WWW.EHWACHS.COM

REV.	STANDARD LX (DIESEL - VMS) (RH)	SCALE	1:12
DATE	01/22/2019	HEET	3/12
DATE	01/22/2019	HEET	2/07/17
DATE	01/22/2019	HEET	2/07/17
DATE	01/22/2019	HEET	2/07/17

77-000-54

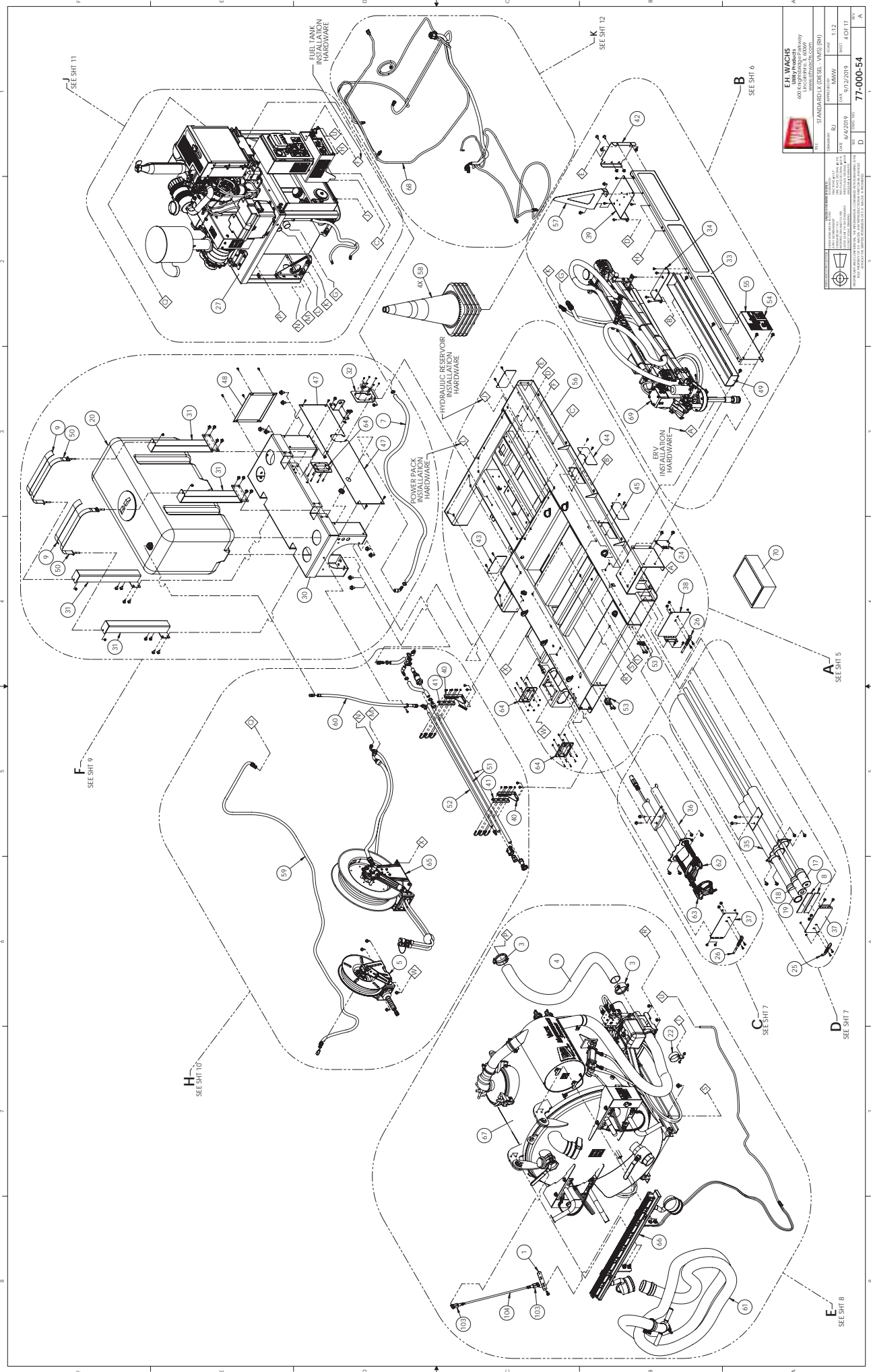

E.H. WACHS		STANDARD LXD SEL - VMSD (RM)	
600 S. HERRING AVENUE		REV. 1.12	
MILWAUKEE, WISCONSIN 53002		DATE: 01/23/2019	
WWW.EHWACHS.COM		REV. 40717	
D		77-000-54	

REVISIONS	
NO.	DESCRIPTION
1	ISSUED FOR MANUFACTURE
2	REVISION
3	REVISION
4	REVISION
5	REVISION
6	REVISION
7	REVISION
8	REVISION
9	REVISION
10	REVISION
11	REVISION
12	REVISION
13	REVISION
14	REVISION
15	REVISION
16	REVISION
17	REVISION
18	REVISION
19	REVISION
20	REVISION
21	REVISION
22	REVISION
23	REVISION
24	REVISION
25	REVISION
26	REVISION
27	REVISION
28	REVISION
29	REVISION
30	REVISION
31	REVISION
32	REVISION
33	REVISION
34	REVISION
35	REVISION
36	REVISION
37	REVISION
38	REVISION
39	REVISION
40	REVISION
41	REVISION
42	REVISION
43	REVISION
44	REVISION
45	REVISION
46	REVISION
47	REVISION
48	REVISION
49	REVISION
50	REVISION
51	REVISION
52	REVISION
53	REVISION
54	REVISION
55	REVISION
56	REVISION
57	REVISION
58	REVISION
59	REVISION
60	REVISION
61	REVISION
62	REVISION
63	REVISION
64	REVISION
65	REVISION
66	REVISION
67	REVISION
68	REVISION
69	REVISION
70	REVISION
71	REVISION
72	REVISION
73	REVISION
74	REVISION
75	REVISION
76	REVISION
77	REVISION
78	REVISION
79	REVISION
80	REVISION
81	REVISION
82	REVISION
83	REVISION
84	REVISION
85	REVISION
86	REVISION
87	REVISION
88	REVISION
89	REVISION
90	REVISION
91	REVISION
92	REVISION
93	REVISION
94	REVISION
95	REVISION
96	REVISION
97	REVISION
98	REVISION
99	REVISION
100	REVISION
101	REVISION
102	REVISION
103	REVISION

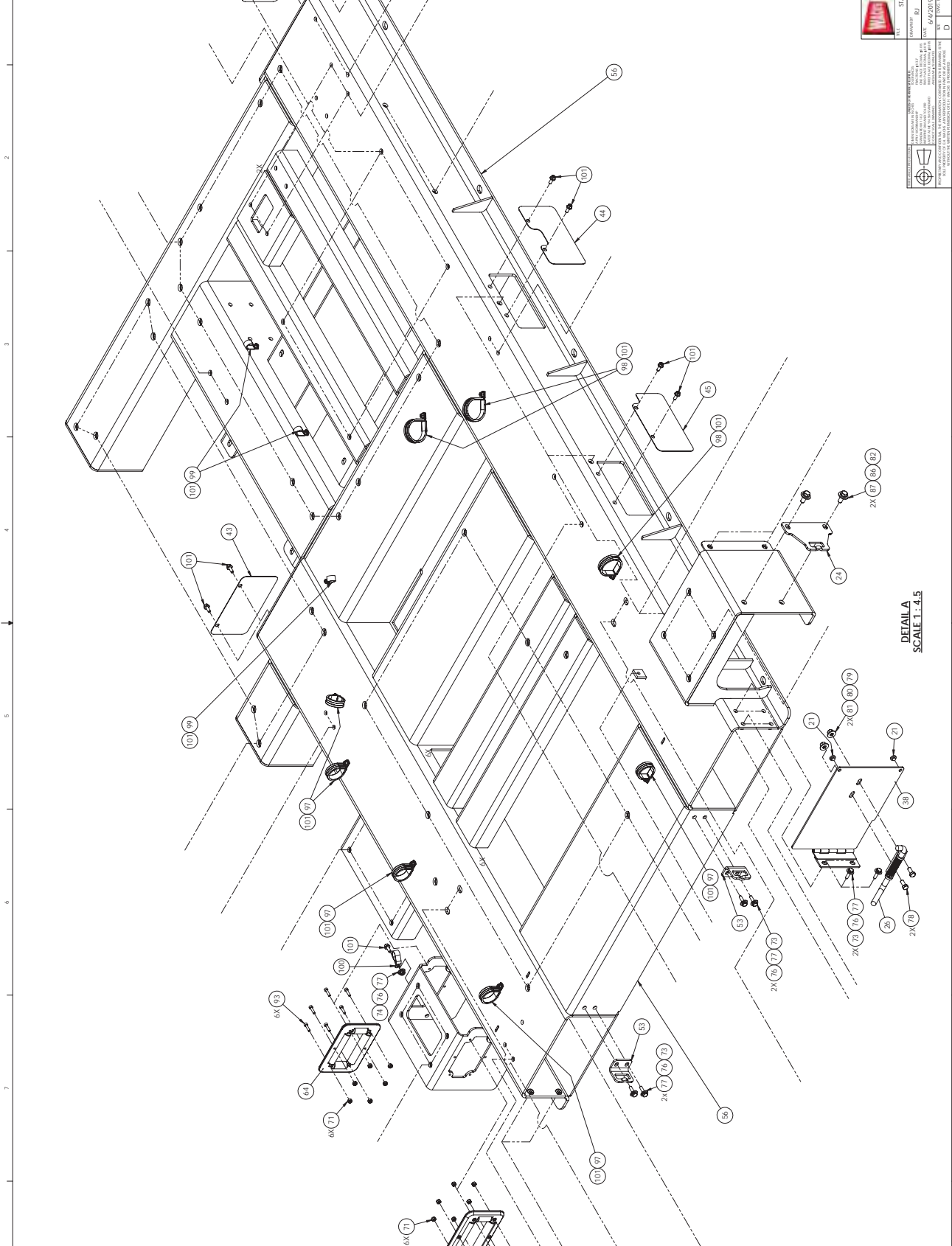

DETAIL A
SCALE 1:4.5

		E.H. WACHS 600 Kappelbergstrasse 70564 Stuttgart, Germany www.ehwachs.com	
PROJ. NO.	STANDARD LX (DESEL - VMR) (RH)	SCALE	1:3
DATE	01/22/2019	REV	001/17
DESIGNED BY	01/22/2019	REV	0001/00
D		77-000-54	

E.H. WACHS 600 Kappelbergstrasse 70564 Stuttgart, Germany www.ehwachs.com		1:3 001/17 0001/00	
77-000-54 STANDARD LX (DESEL - VMR) (RH)		01/22/2019	

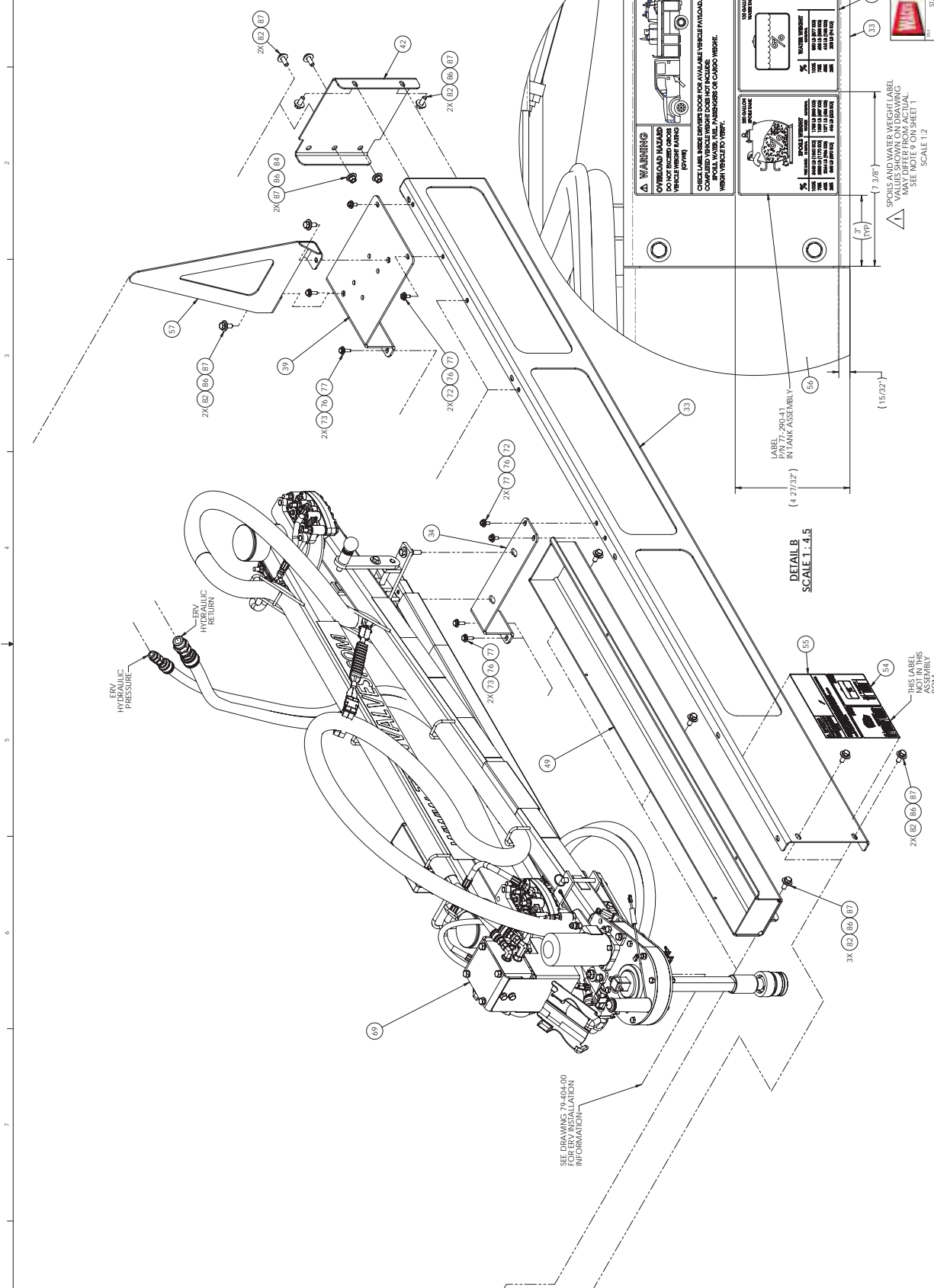

ERV
HYDRAULIC
PRESSURE

ERV
HYDRAULIC
RETURN

SEE DRAWINGS 79-404-00
FOR
ADDITIONAL
INFORMATION

THIS LABEL
IS NOT TO BE
ASSEMBLED
FROM

DETAIL B
SCALE 1:4.5

SPOLS AND WATER RESISTANT LABEL
VALUES SHOWN ON DRAWING
MAY DIFFER FROM ACTUAL.
SEE DRAWING 79-404-00 FOR
ADDITIONAL INFORMATION.
SCALE 1:2

WARNING
OVERLOAD HAZARD
CHECK LABEL DRIVERS DOOR FOR AVAILABLE VEHICLE PAYLOAD.
VEHICLES EXCEEDING PAYLOAD MAY BE UNSTEADY AND
DANGEROUS. ALWAYS WEIGH LOADS AND VEHICLES TO VERIFY
LOADS ARE WITHIN PAYLOAD CAPACITY.
VEHICLES WITH VARIOUS LOADS MAY BE UNSTEADY AND
DANGEROUS. ALWAYS WEIGH LOADS AND VEHICLES TO VERIFY
LOADS ARE WITHIN PAYLOAD CAPACITY.

SAFETY INFORMATION
NEVER OPERATE VEHICLE WITH
SEAT BELT UNFASTENED
OR WITH AIR BAGS
DEACTIVATED. ALWAYS
WEAR SEAT BELT
AND USE AIR BAGS
PROPERLY.
NEVER DRINK AND DRIVE.
NEVER OPERATE VEHICLE
IF YOU FEEL FATIGUED OR
DROWSY.

SAFETY INFORMATION
NEVER OPERATE VEHICLE WITH
SEAT BELT UNFASTENED
OR WITH AIR BAGS
DEACTIVATED. ALWAYS
WEAR SEAT BELT
AND USE AIR BAGS
PROPERLY.
NEVER DRINK AND DRIVE.
NEVER OPERATE VEHICLE
IF YOU FEEL FATIGUED OR
DROWSY.

SAFETY INFORMATION
NEVER OPERATE VEHICLE WITH
SEAT BELT UNFASTENED
OR WITH AIR BAGS
DEACTIVATED. ALWAYS
WEAR SEAT BELT
AND USE AIR BAGS
PROPERLY.
NEVER DRINK AND DRIVE.
NEVER OPERATE VEHICLE
IF YOU FEEL FATIGUED OR
DROWSY.

SAFETY INFORMATION
NEVER OPERATE VEHICLE WITH
SEAT BELT UNFASTENED
OR WITH AIR BAGS
DEACTIVATED. ALWAYS
WEAR SEAT BELT
AND USE AIR BAGS
PROPERLY.
NEVER DRINK AND DRIVE.
NEVER OPERATE VEHICLE
IF YOU FEEL FATIGUED OR
DROWSY.

SAFETY INFORMATION
NEVER OPERATE VEHICLE WITH
SEAT BELT UNFASTENED
OR WITH AIR BAGS
DEACTIVATED. ALWAYS
WEAR SEAT BELT
AND USE AIR BAGS
PROPERLY.
NEVER DRINK AND DRIVE.
NEVER OPERATE VEHICLE
IF YOU FEEL FATIGUED OR
DROWSY.

SAFETY INFORMATION
NEVER OPERATE VEHICLE WITH
SEAT BELT UNFASTENED
OR WITH AIR BAGS
DEACTIVATED. ALWAYS
WEAR SEAT BELT
AND USE AIR BAGS
PROPERLY.
NEVER DRINK AND DRIVE.
NEVER OPERATE VEHICLE
IF YOU FEEL FATIGUED OR
DROWSY.

SAFETY INFORMATION
NEVER OPERATE VEHICLE WITH
SEAT BELT UNFASTENED
OR WITH AIR BAGS
DEACTIVATED. ALWAYS
WEAR SEAT BELT
AND USE AIR BAGS
PROPERLY.
NEVER DRINK AND DRIVE.
NEVER OPERATE VEHICLE
IF YOU FEEL FATIGUED OR
DROWSY.

SAFETY INFORMATION
NEVER OPERATE VEHICLE WITH
SEAT BELT UNFASTENED
OR WITH AIR BAGS
DEACTIVATED. ALWAYS
WEAR SEAT BELT
AND USE AIR BAGS
PROPERLY.
NEVER DRINK AND DRIVE.
NEVER OPERATE VEHICLE
IF YOU FEEL FATIGUED OR
DROWSY.

E.H. WACHS		DATE	SCALE	REV
600 E. Highway 100, Suite 100		01/23/2019	1:6	001
STANDARD LX DIESEL - VM8 (R8)		04/28/2018		002
www.ehwachs.com		07/20/2019		003
		09/12/2019		004
		01/23/2019		005
				006
				007
				008
				009
				010
				011
				012
				013
				014
				015
				016
				017
				018
				019
				020
				021
				022
				023
				024
				025
				026
				027
				028
				029
				030
				031
				032
				033
				034
				035
				036
				037
				038
				039
				040
				041
				042
				043
				044
				045
				046
				047
				048
				049
				050
				051
				052
				053
				054
				055
				056
				057
				058
				059
				060
				061
				062
				063
				064
				065
				066
				067
				068
				069
				070
				071
				072
				073
				074
				075
				076
				077
				078
				079
				080
				081
				082
				083
				084
				085
				086
				087
				088
				089
				090
				091
				092
				093
				094
				095
				096
				097
				098
				099
				100

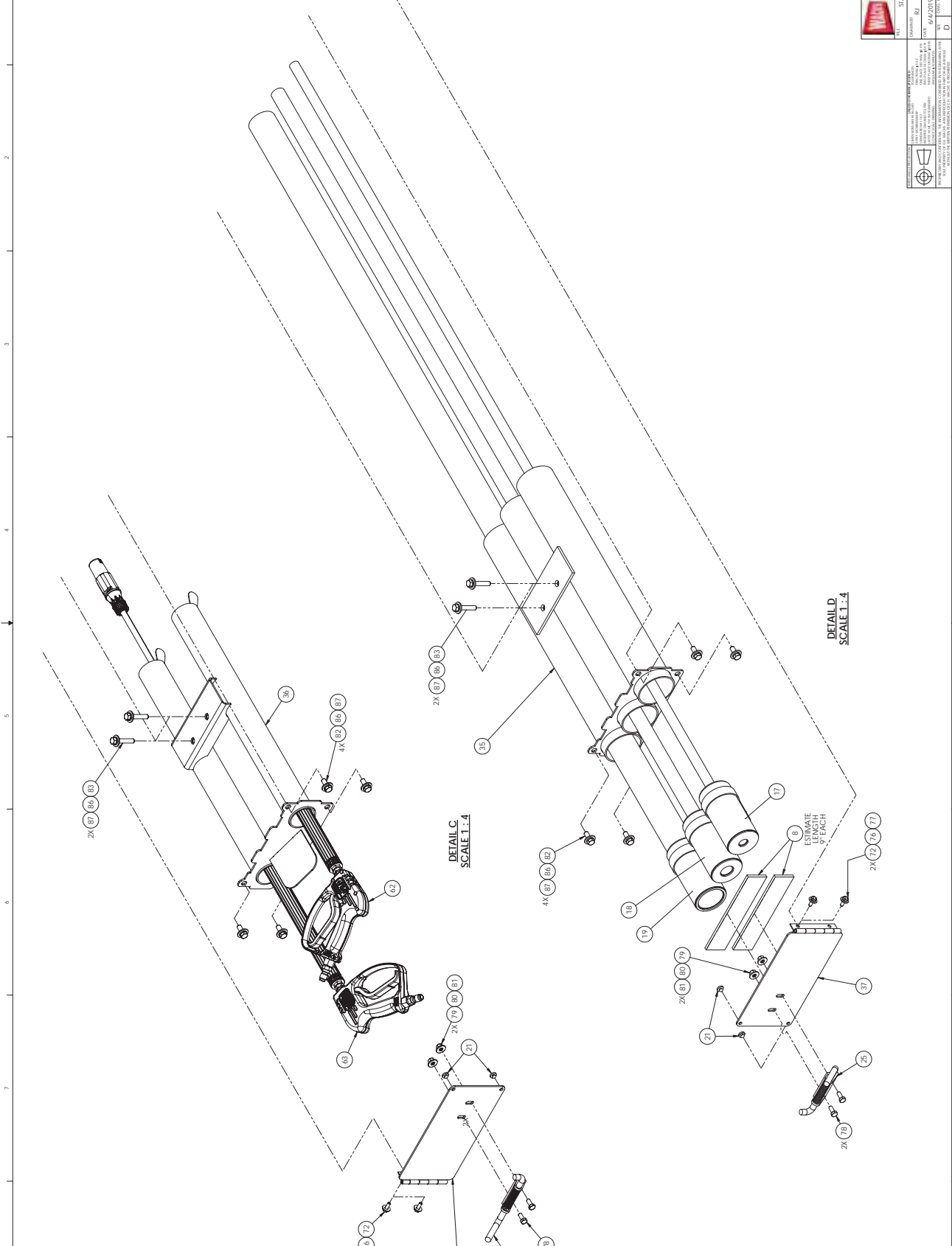

E.H. WACHS
 600 KENNEDY BOULEVARD
 WASHINGTON, DC 20002
 WWW.EHWACHS.COM

REV	STANDARD LXD DIESEL VMRS (RH)	SCALE	1:12
DATE	01/23/2019	SHEET	7 OF 17
DESIGNER	RL	PROJECT NO.	77-000-54
DRAWN	RL	DATE	04/22/2018
CHECKED	RL	REV	0001-000
APPROVED	RL	REV	0001-000

	E.H. WACHS 600 KENNEDY BOULEVARD WASHINGTON, DC 20002 WWW.EHWACHS.COM	100% INSPECTION ALL DIMENSIONS ARE TO UNLESS OTHERWISE SPECIFIED DIMENSIONS ARE IN INCHES AND DECIMALS THEREOF DIMENSIONS ARE TO UNLESS OTHERWISE SPECIFIED DIMENSIONS ARE IN MILLIMETERS AND DECIMALS THEREOF DIMENSIONS ARE TO UNLESS OTHERWISE SPECIFIED DIMENSIONS ARE IN MILLIMETERS AND DECIMALS THEREOF
		100% INSPECTION ALL DIMENSIONS ARE TO UNLESS OTHERWISE SPECIFIED DIMENSIONS ARE IN INCHES AND DECIMALS THEREOF DIMENSIONS ARE TO UNLESS OTHERWISE SPECIFIED DIMENSIONS ARE IN MILLIMETERS AND DECIMALS THEREOF DIMENSIONS ARE TO UNLESS OTHERWISE SPECIFIED DIMENSIONS ARE IN MILLIMETERS AND DECIMALS THEREOF



DETAIL
SCALE 1:6

		E.H. WACHS 600 North Highway 100 Westborough, MA 01581 www.waltusa.com	
ITEM: STANDARD DIESEL - VMS (RH)	DRAWING: RL	SCALE: 1:6	SHEET: 6 OF 17
DATE: 01/22/2019	DATE: 04/20/18	DES: 67001-54	DES: 67001-54
77-001-54		D	

10
68
SEE SH111

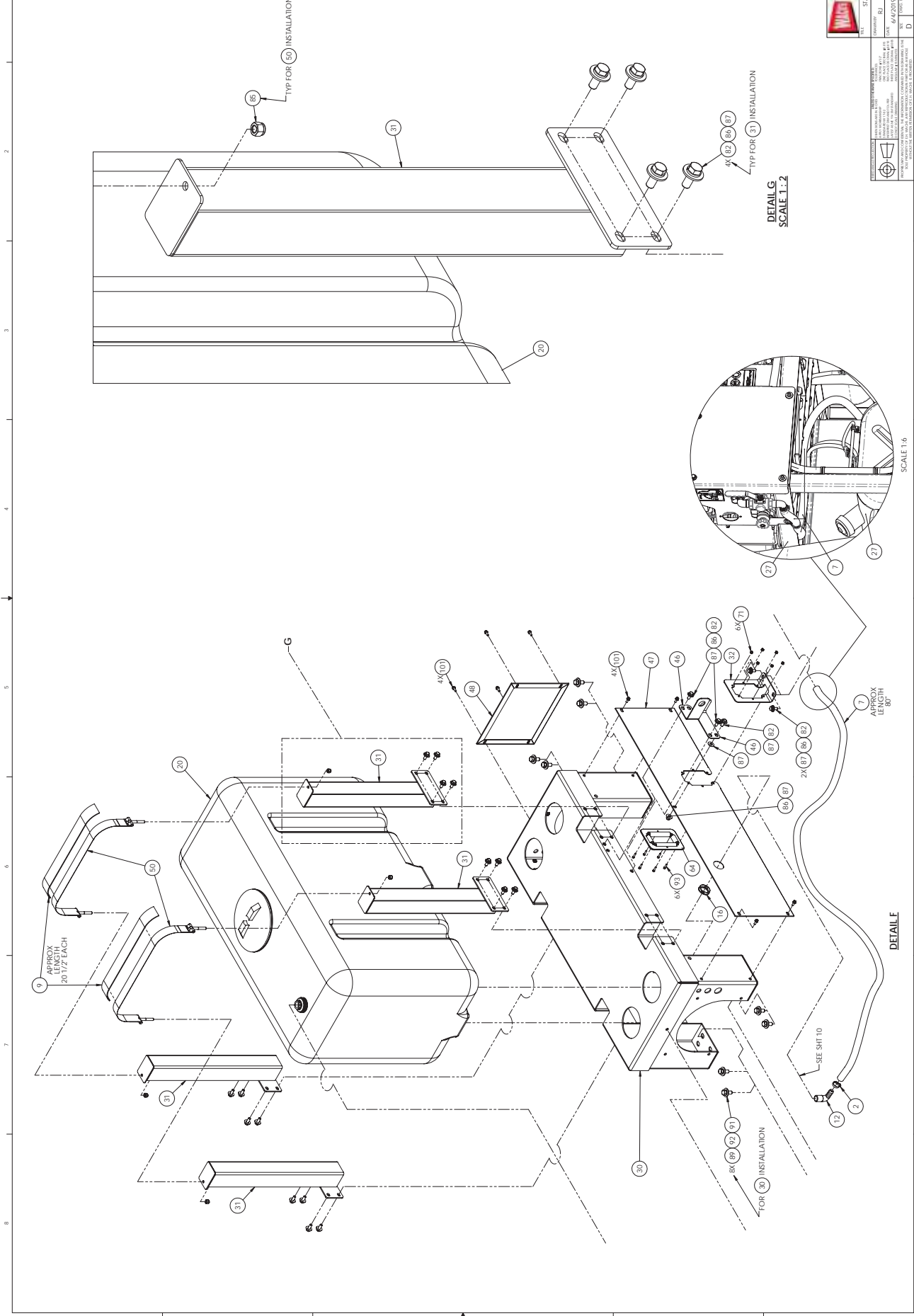

DETAIL

SCALE 1:6

DETAIL G
SCALE 1:2

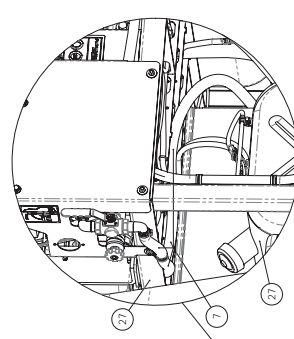

		E.H. WACHS 600 KENTWOOD DRIVE WYOMING, OHIO 43085 WWW.WACHS.COM	
DRAWING NO. 77-000-54	REV. D	DATE 01/22/2019	SHEET NO. 17
DRAWING BY RL	APPROVED BY AWW	DATE 01/22/2019	SHEET NO. 17
PART NO. 77-000-54	PART NAME POST 17	PART NO. 77-000-54	PART NAME POST 17

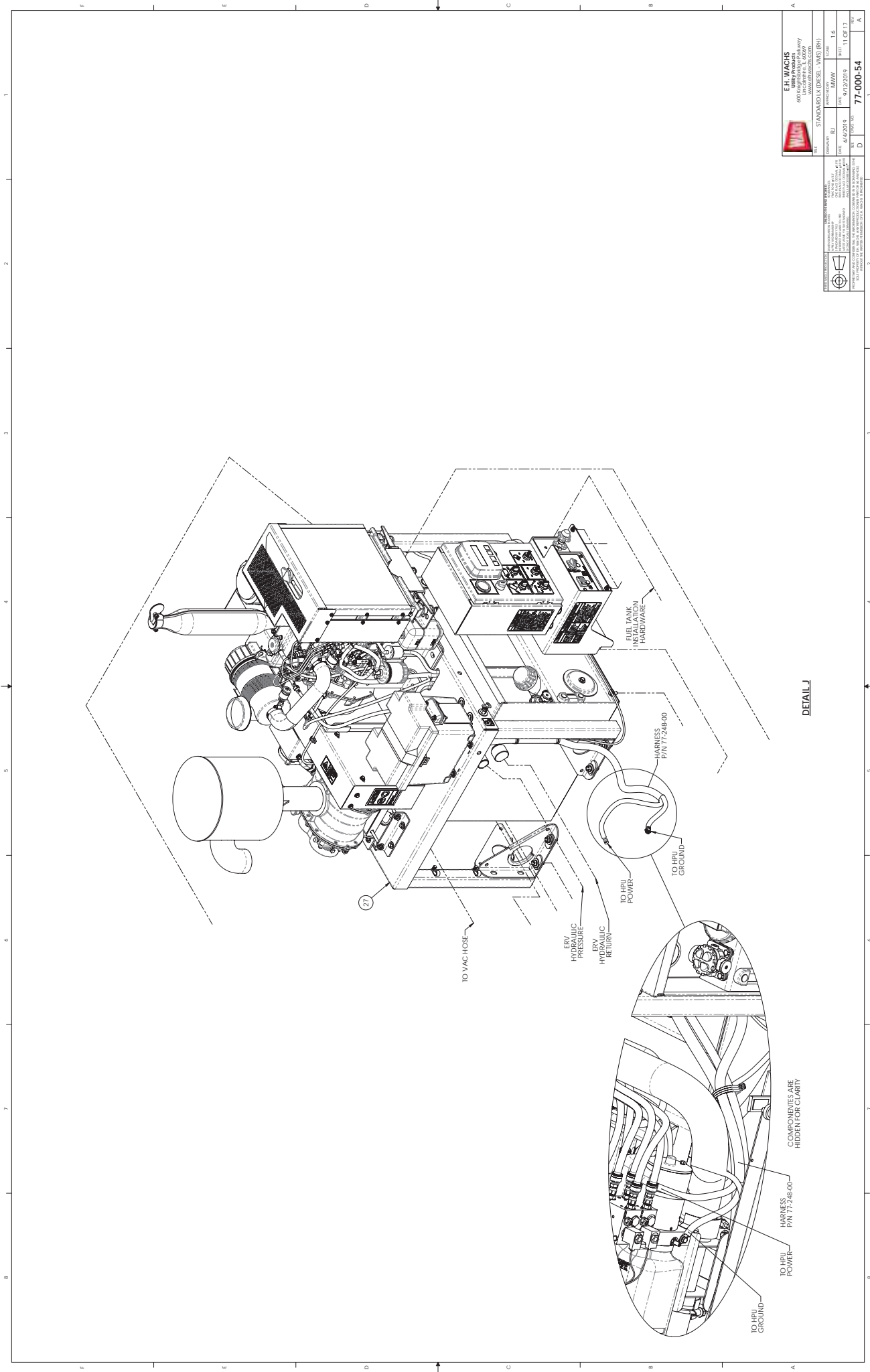

DETAIL J

		E.H. WACHS 600 N. Highway 101, Suite 100 San Marcos, CA 92069 www.ehwachs.com	
REV	STANDARD LX DIESEL - VMS (RH)	SCALE	1:6
DATE	01/22/2019	REV	1 OF 1
DATE	04/2018	REV	11 OF 11
REV	0001-000	REV	0001-000
D	77-000-54		

THIS DRAWING IS THE PROPERTY OF E.H. WACHS. IT IS TO BE USED ONLY FOR THE PROJECT AND QUANTITY SPECIFIED. IT IS NOT TO BE REPRODUCED OR TRANSMITTED IN ANY FORM OR BY ANY MEANS, ELECTRONIC OR MECHANICAL, INCLUDING PHOTOCOPYING, RECORDING, OR BY ANY INFORMATION STORAGE AND RETRIEVAL SYSTEM. WITHOUT THE WRITTEN PERMISSION OF E.H. WACHS, THIS DRAWING IS NOT TO BE USED FOR ANY OTHER PROJECT OR QUANTITY.

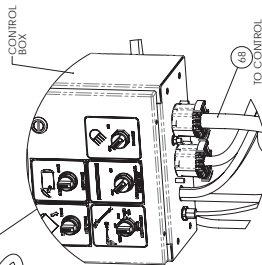
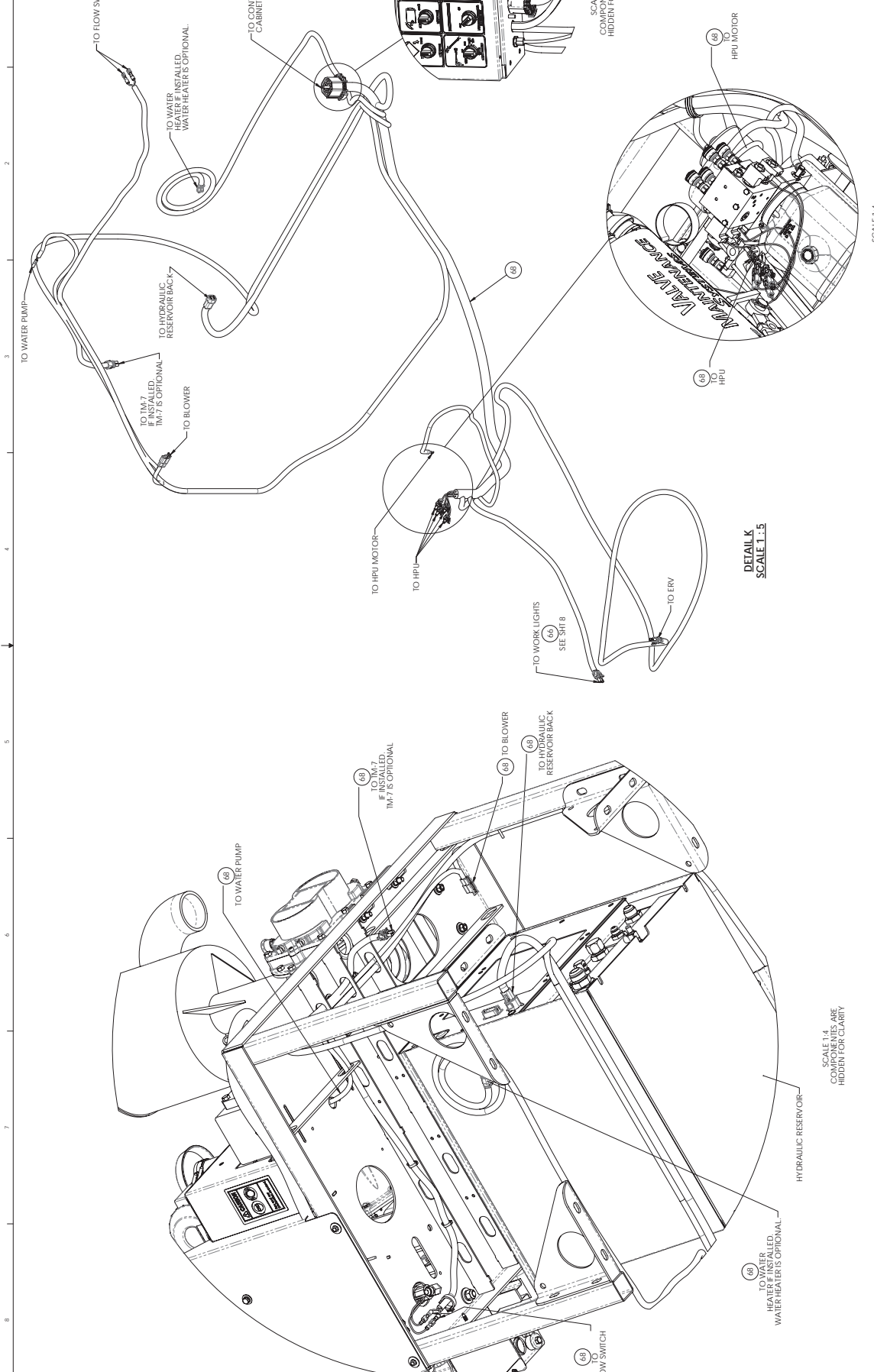

SCALE 1:4
COMPONENTS ARE
HIDDEN FOR CLARITY

DETAIL K
SCALE 1:5

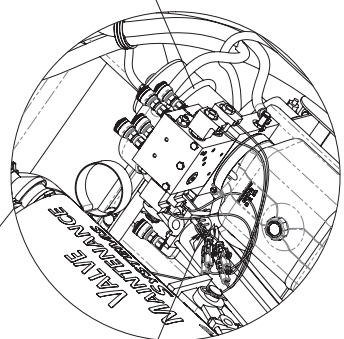

SCALE 1:4
COMPONENTS ARE
HIDDEN FOR CLARITY

SCALE 1:4
COMPONENTS ARE
HIDDEN FOR CLARITY

E.H. WACHS
609 S. Highway 100
Wachs, TX 75787
www.wachsbros.com

REV	STANDARD Lx D (SEL. VARS (RHS))	SCALE	1:5
DATE	01/22/2019	REV	12 OF 12
DATE	04/25/18	REV	12 OF 12
DATE	03/02/10	REV	12 OF 12
DATE	03/02/10	REV	12 OF 12

77-000-54

REV	DATE	BY	APP'D	DESCRIPTION
1	03/02/10
2	03/02/10
3	03/02/10
4	03/02/10
5	03/02/10
6	03/02/10
7	03/02/10
8	03/02/10
9	03/02/10
10	03/02/10

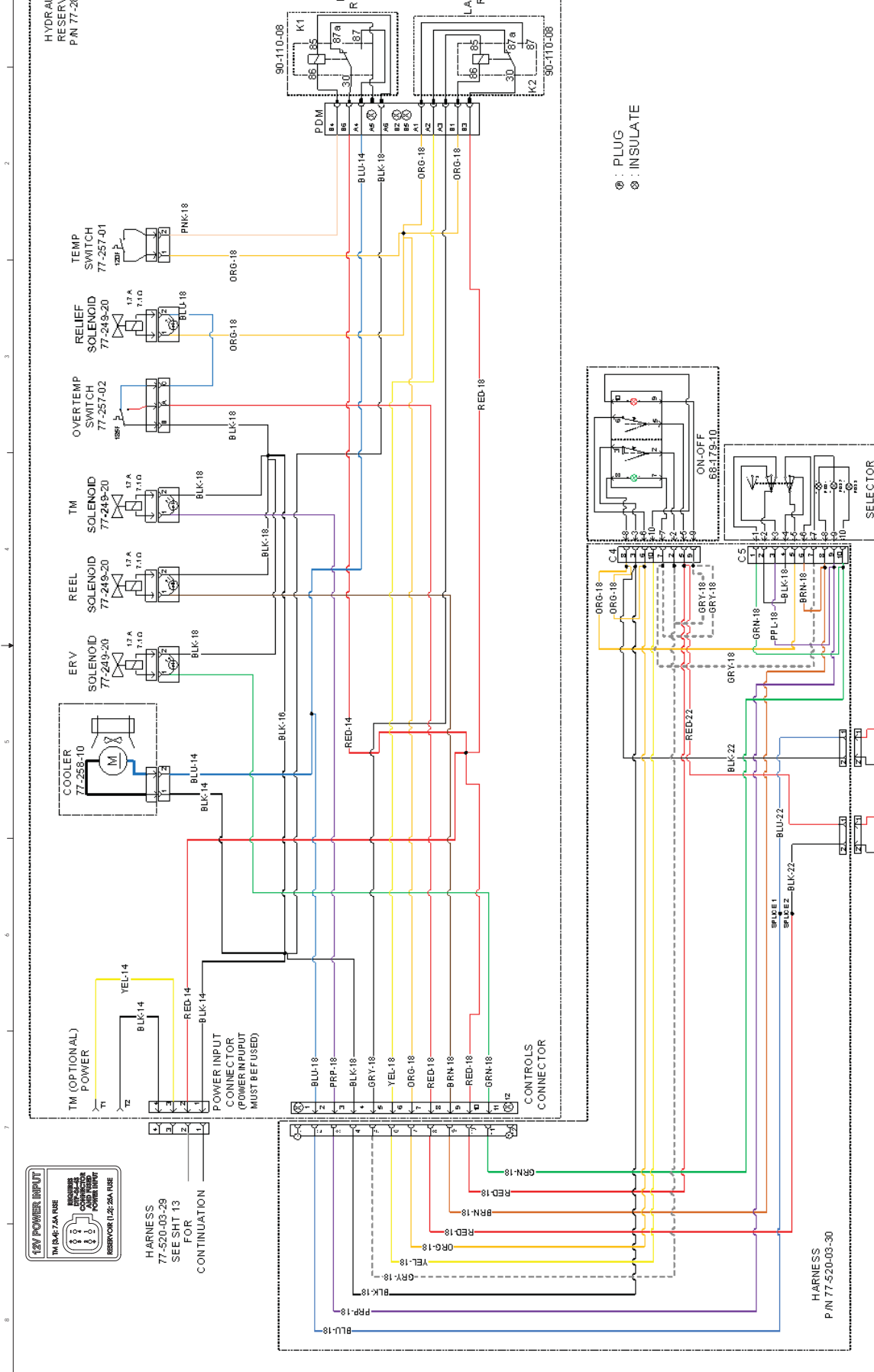

E.H. WACHS 600 N. HARRIS BLVD MILWAUKEE, WI 53206 WWW.EHWACHS.COM		DATE	SCALE
REV	DESCRIPTION	BY	CHK
1	STANDARD L X (DESEL - VAS) (R)	MMW	I.S.
2	REVISED TO ADD 12V POWER INPUT	MMW	I.S.
3	REVISED TO ADD 12V POWER INPUT	MMW	I.S.
4	REVISED TO ADD 12V POWER INPUT	MMW	I.S.
5	REVISED TO ADD 12V POWER INPUT	MMW	I.S.
6	REVISED TO ADD 12V POWER INPUT	MMW	I.S.
7	REVISED TO ADD 12V POWER INPUT	MMW	I.S.
8	REVISED TO ADD 12V POWER INPUT	MMW	I.S.
9	REVISED TO ADD 12V POWER INPUT	MMW	I.S.
10	REVISED TO ADD 12V POWER INPUT	MMW	I.S.
11	REVISED TO ADD 12V POWER INPUT	MMW	I.S.
12	REVISED TO ADD 12V POWER INPUT	MMW	I.S.
13	REVISED TO ADD 12V POWER INPUT	MMW	I.S.
14	REVISED TO ADD 12V POWER INPUT	MMW	I.S.
15	REVISED TO ADD 12V POWER INPUT	MMW	I.S.
16	REVISED TO ADD 12V POWER INPUT	MMW	I.S.
17	REVISED TO ADD 12V POWER INPUT	MMW	I.S.
18	REVISED TO ADD 12V POWER INPUT	MMW	I.S.
19	REVISED TO ADD 12V POWER INPUT	MMW	I.S.
20	REVISED TO ADD 12V POWER INPUT	MMW	I.S.
21	REVISED TO ADD 12V POWER INPUT	MMW	I.S.
22	REVISED TO ADD 12V POWER INPUT	MMW	I.S.
23	REVISED TO ADD 12V POWER INPUT	MMW	I.S.
24	REVISED TO ADD 12V POWER INPUT	MMW	I.S.
25	REVISED TO ADD 12V POWER INPUT	MMW	I.S.
26	REVISED TO ADD 12V POWER INPUT	MMW	I.S.
27	REVISED TO ADD 12V POWER INPUT	MMW	I.S.
28	REVISED TO ADD 12V POWER INPUT	MMW	I.S.
29	REVISED TO ADD 12V POWER INPUT	MMW	I.S.
30	REVISED TO ADD 12V POWER INPUT	MMW	I.S.
31	REVISED TO ADD 12V POWER INPUT	MMW	I.S.
32	REVISED TO ADD 12V POWER INPUT	MMW	I.S.
33	REVISED TO ADD 12V POWER INPUT	MMW	I.S.
34	REVISED TO ADD 12V POWER INPUT	MMW	I.S.
35	REVISED TO ADD 12V POWER INPUT	MMW	I.S.
36	REVISED TO ADD 12V POWER INPUT	MMW	I.S.
37	REVISED TO ADD 12V POWER INPUT	MMW	I.S.
38	REVISED TO ADD 12V POWER INPUT	MMW	I.S.
39	REVISED TO ADD 12V POWER INPUT	MMW	I.S.
40	REVISED TO ADD 12V POWER INPUT	MMW	I.S.
41	REVISED TO ADD 12V POWER INPUT	MMW	I.S.
42	REVISED TO ADD 12V POWER INPUT	MMW	I.S.
43	REVISED TO ADD 12V POWER INPUT	MMW	I.S.
44	REVISED TO ADD 12V POWER INPUT	MMW	I.S.
45	REVISED TO ADD 12V POWER INPUT	MMW	I.S.
46	REVISED TO ADD 12V POWER INPUT	MMW	I.S.
47	REVISED TO ADD 12V POWER INPUT	MMW	I.S.
48	REVISED TO ADD 12V POWER INPUT	MMW	I.S.
49	REVISED TO ADD 12V POWER INPUT	MMW	I.S.
50	REVISED TO ADD 12V POWER INPUT	MMW	I.S.
51	REVISED TO ADD 12V POWER INPUT	MMW	I.S.
52	REVISED TO ADD 12V POWER INPUT	MMW	I.S.
53	REVISED TO ADD 12V POWER INPUT	MMW	I.S.
54	REVISED TO ADD 12V POWER INPUT	MMW	I.S.
55	REVISED TO ADD 12V POWER INPUT	MMW	I.S.
56	REVISED TO ADD 12V POWER INPUT	MMW	I.S.
57	REVISED TO ADD 12V POWER INPUT	MMW	I.S.
58	REVISED TO ADD 12V POWER INPUT	MMW	I.S.
59	REVISED TO ADD 12V POWER INPUT	MMW	I.S.
60	REVISED TO ADD 12V POWER INPUT	MMW	I.S.
61	REVISED TO ADD 12V POWER INPUT	MMW	I.S.
62	REVISED TO ADD 12V POWER INPUT	MMW	I.S.
63	REVISED TO ADD 12V POWER INPUT	MMW	I.S.
64	REVISED TO ADD 12V POWER INPUT	MMW	I.S.
65	REVISED TO ADD 12V POWER INPUT	MMW	I.S.
66	REVISED TO ADD 12V POWER INPUT	MMW	I.S.
67	REVISED TO ADD 12V POWER INPUT	MMW	I.S.
68	REVISED TO ADD 12V POWER INPUT	MMW	I.S.
69	REVISED TO ADD 12V POWER INPUT	MMW	I.S.
70	REVISED TO ADD 12V POWER INPUT	MMW	I.S.
71	REVISED TO ADD 12V POWER INPUT	MMW	I.S.
72	REVISED TO ADD 12V POWER INPUT	MMW	I.S.
73	REVISED TO ADD 12V POWER INPUT	MMW	I.S.
74	REVISED TO ADD 12V POWER INPUT	MMW	I.S.
75	REVISED TO ADD 12V POWER INPUT	MMW	I.S.
76	REVISED TO ADD 12V POWER INPUT	MMW	I.S.
77	REVISED TO ADD 12V POWER INPUT	MMW	I.S.
78	REVISED TO ADD 12V POWER INPUT	MMW	I.S.
79	REVISED TO ADD 12V POWER INPUT	MMW	I.S.
80	REVISED TO ADD 12V POWER INPUT	MMW	I.S.
81	REVISED TO ADD 12V POWER INPUT	MMW	I.S.
82	REVISED TO ADD 12V POWER INPUT	MMW	I.S.
83	REVISED TO ADD 12V POWER INPUT	MMW	I.S.
84	REVISED TO ADD 12V POWER INPUT	MMW	I.S.
85	REVISED TO ADD 12V POWER INPUT	MMW	I.S.
86	REVISED TO ADD 12V POWER INPUT	MMW	I.S.
87	REVISED TO ADD 12V POWER INPUT	MMW	I.S.
88	REVISED TO ADD 12V POWER INPUT	MMW	I.S.
89	REVISED TO ADD 12V POWER INPUT	MMW	I.S.
90	REVISED TO ADD 12V POWER INPUT	MMW	I.S.
91	REVISED TO ADD 12V POWER INPUT	MMW	I.S.
92	REVISED TO ADD 12V POWER INPUT	MMW	I.S.
93	REVISED TO ADD 12V POWER INPUT	MMW	I.S.
94	REVISED TO ADD 12V POWER INPUT	MMW	I.S.
95	REVISED TO ADD 12V POWER INPUT	MMW	I.S.
96	REVISED TO ADD 12V POWER INPUT	MMW	I.S.
97	REVISED TO ADD 12V POWER INPUT	MMW	I.S.
98	REVISED TO ADD 12V POWER INPUT	MMW	I.S.
99	REVISED TO ADD 12V POWER INPUT	MMW	I.S.
100	REVISED TO ADD 12V POWER INPUT	MMW	I.S.

ELECTRIC SCHEMATIC
 SEE SHT 13 FOR CONTINUATION

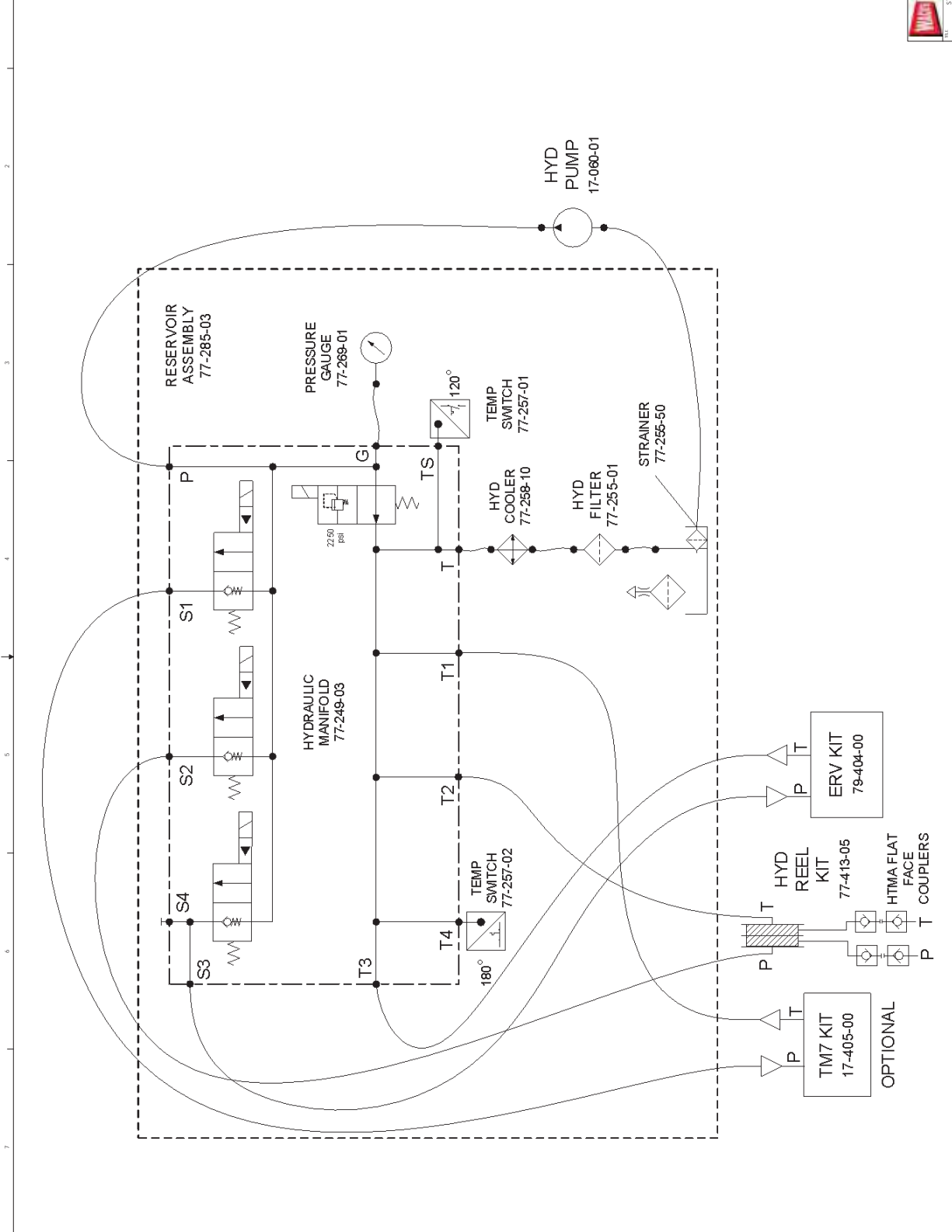

HYDRAULIC SCHEMATIC

		E.H. WACHS 600 N. Highway 100, Suite 100 Phoenix, AZ 85024 Phone: (602) 998-8888 Fax: (602) 998-8889 www.ehwachs.com
DRAWING NO. 77-000-54	REV. D	DATE 04/28/18
DESIGNED BY STANDARD, L. (DESEL, L. WAS) (R)	CHECKED BY ICAM, I.A.S.	DATE 05/01/18

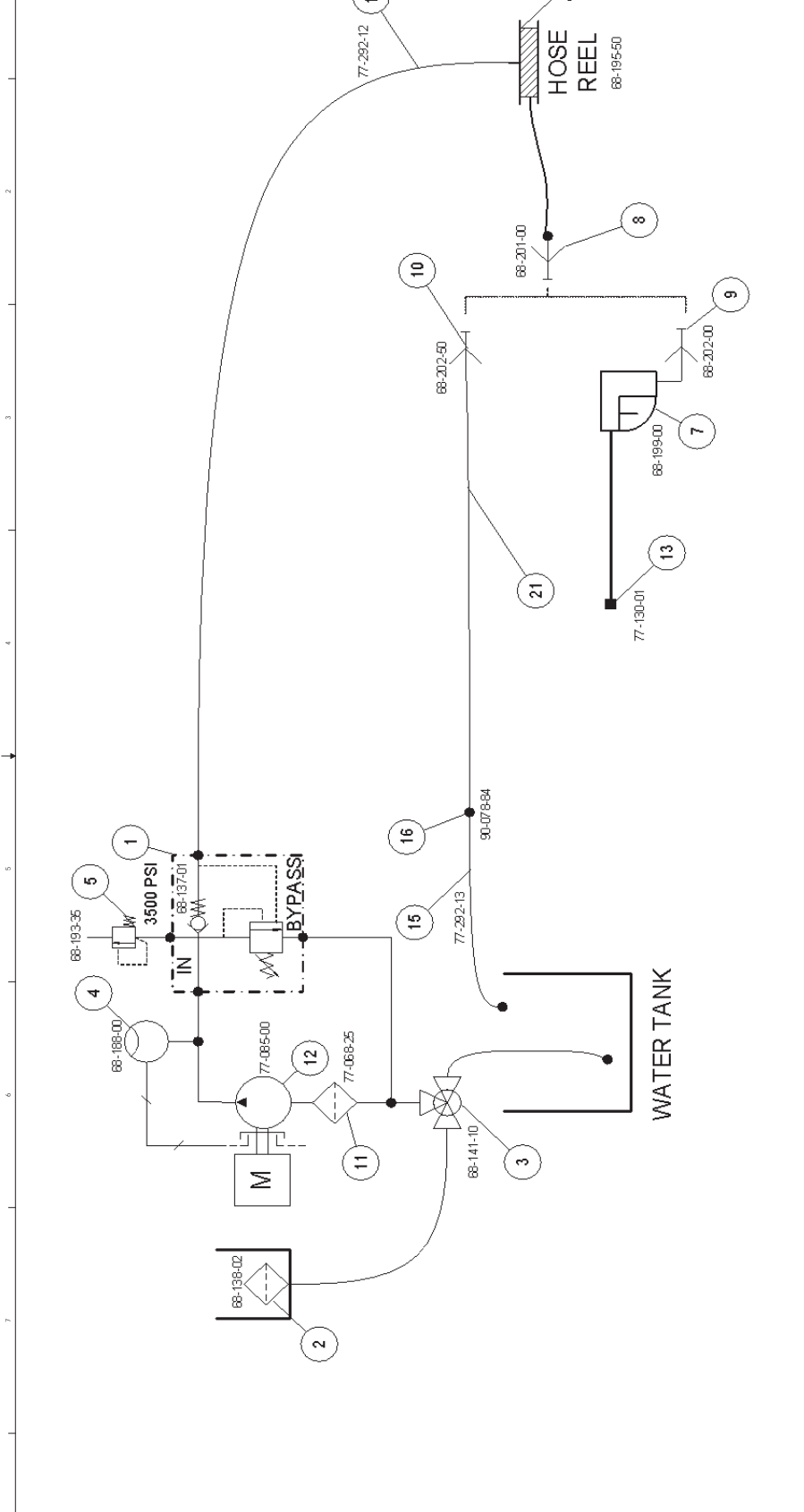

PARTS LIST FOR PRESSURE WASHER SYSTEM SCHEMATICS. REFERENCE ONLY. BALLOONS DO NOT CORRESPOND WITH ROW TABLE ON SHEET 3

SCHEMATIC ITEM	PART NUMBER	DESCRIPTION
1	68-138-01	VALVE, TRAPPED PRESSURE UNLOADER
2	68-138-02	STRAINER
3	68-141-10	BALL VALVE, 3-WAY
4	68-188-00	FLOW SWITCH
5	68-192-35	SAFETY RELIEF, 3500 PSI
6	68-195-50	HOSE REEL
7	68-199-00	SPRAY GUN
8	68-201-00	OD COUPLER, 3/8" X 3/8" NPT-F
9	68-202-00	OD PLUG, 3/8" X 3/8" NPT-M
10	68-202-50	OD PLUG, 3/8" X 3/8" NPT-F
11	77-069-25	STRAINER
12	77-085-00	PUMP PRESSURE WASHER 2.6 GPM, 3000 PSI
13	77-130-01	NOZZLE, .030 X 15 DEGREE
14	77-292-12	151 5/16" HOSE ASSEMBLY, .08 E.I. X .08 F.I. X .08 HOSE
15	77-292-13	43 13/16" HOSE ASSEMBLY, .08 E.I. X .08 F.I. X .08 HOSE
16	90-076-84	ADAPTER, 8 (3/4" - 1.625) X 3/8" NPT-F 90

PRESSURE WASHER SYSTEM SCHEMATIC

E.H. WACHS
 600 KENTWOOD DRIVE
 WILSON, NC 27894
 WWW.EHWACHS.COM

REV	STANDARD L.A. (DESEL - VMS) (RH)	SCALE	1:12
DATE	01/22/2019	DESIGNED BY	AW
DATE	04/22/2018	DRAWN BY	AW
DATE	02/02/2017	CHECKED BY	AW
DATE	02/02/2017	APPROVED BY	AW

77-000-54

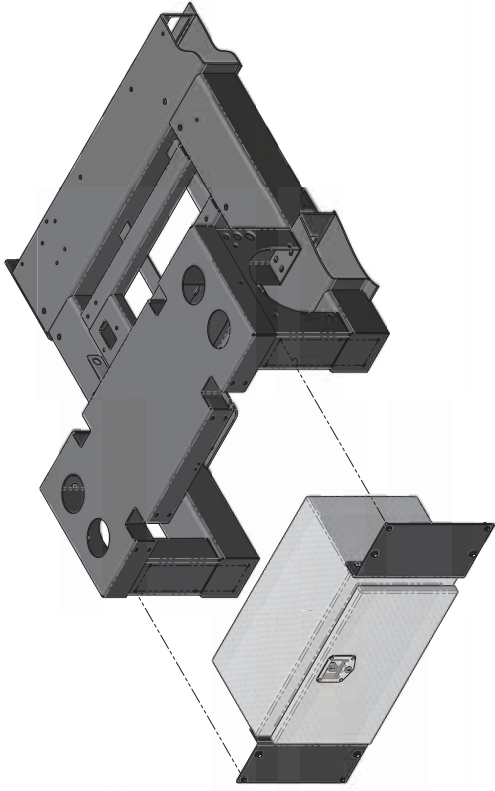

P/N 77-406-05
JOB BOX FOR VMS KIT
NOT AVAILABLE WITH TM-7

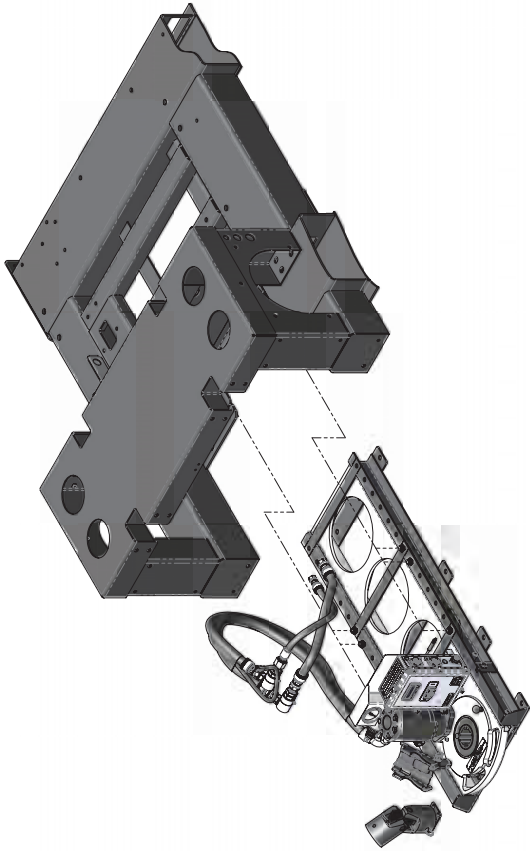

P/N 77-406-09
TM-7 HD PLUS FOR VMS KIT
NOT AVAILABLE WITH JOB BOX

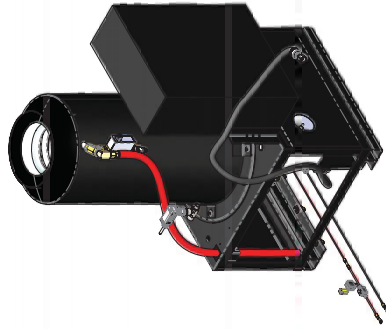

P/N 77-414-02
WATER HEATER - VMS KIT

AVAILABLE OPTIONS

		E.H. WACHS 600 North Highway 100 Waco, TX 76798 www.ehwachs.com	
REV	STANDARD LX DIESEL - VMS (RH)	SCALE	1:8
DATE	01/22/2019	DATE	07/01/18
DESIGNED BY	04/28/18	DATE	07/01/18
REV	0001	DATE	07/01/18
D		77-000-54	

- NOTES:
1. MATERIAL PER COMPONENT
 2. FINISH PER COMPONENT
 3. APPROX WEIGHT; SEE WEIGHT AND CENTER OF GRAVITY TABLE
 4. DIMENSIONS FOR CONTINUATION OF EXPLODED LINE:
 5. SEE SHEET 13 AND 14 FOR ELECTRIC SCHEMATIC
 6. SEE SHEET 15 FOR HYDRAULIC SCHEMATIC
 7. SEE SHEET 16 FOR HYDRAULIC SCHEMATIC
 8. SKID MUST BE MOUNTED TO A FRAME SUITABLE TO HANDLE WEIGHT OF SKID WITH FULL SPOILS AND FULL WATER.

9. CUSTOMER AND UPRITER ARE RESPONSIBLE FOR NOT WEIGHTING (GVWR), ALL PASSENGERS EQUIPMENT, FUEL, VACUUM SPOILS, WATER, AND CARGO MUST BE ACCOUNTED FOR. UPRITER SHALL SUPPLY A LABEL WITH GVWR AND COMPLETED VEHICLE WEIGHT PLACED ON THE VEHICLE ABOVE ITS GVWR, SPOILS AND WATER WEIGHTS FOR THE SUPPLIED VAS CONFIGURATION ARE PROVIDED ON THE VMS. SEE SHEET 6 FOR LABEL INFORMATION AND PLACEMENT.

REVISION HISTORY			
REV.	DESCRIPTION	DATE	APPR.
A	NEW RELEASE (ECO 1376)	9/27/2019	EMMY

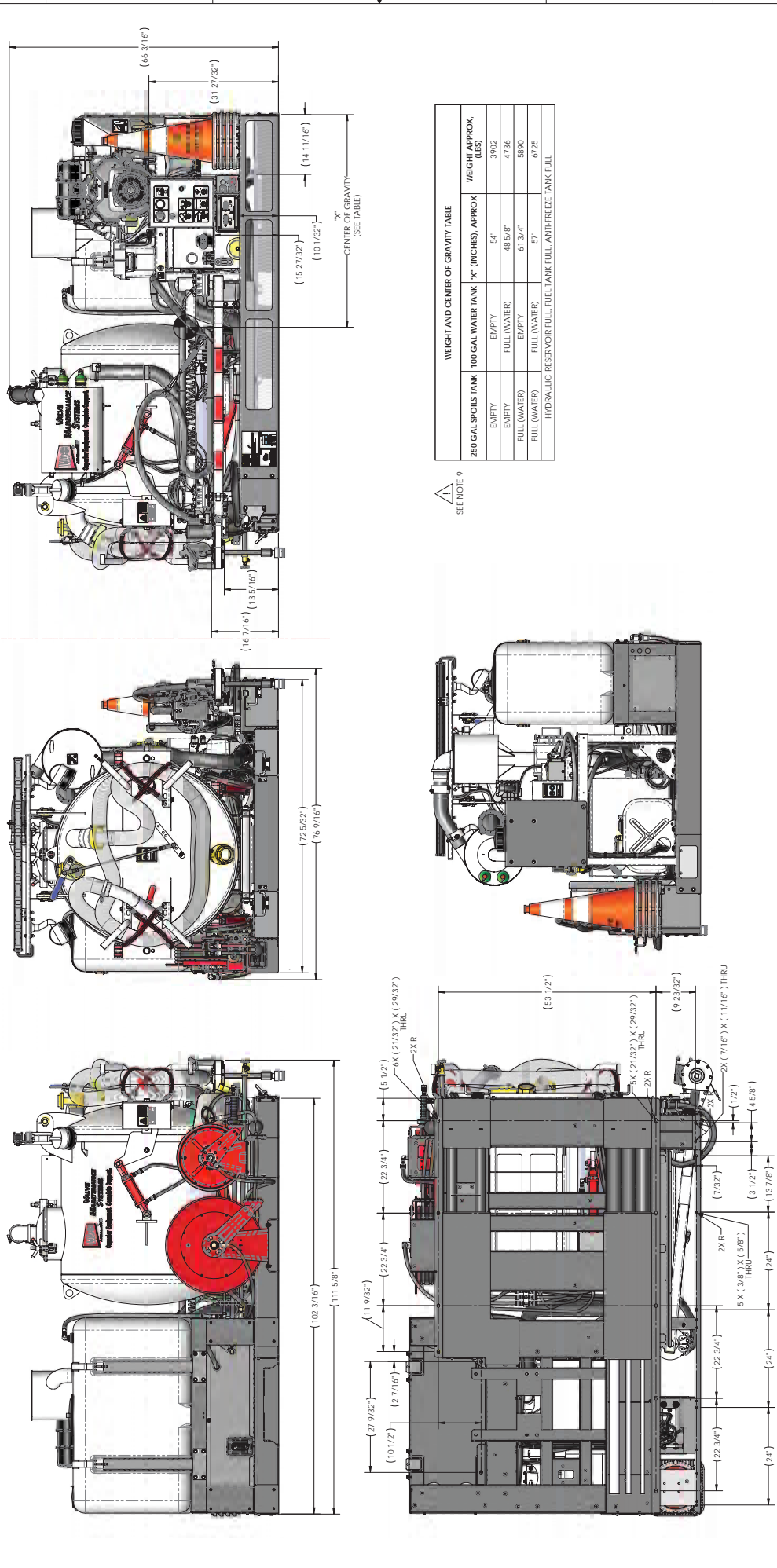

WEIGHT AND CENTER OF GRAVITY TABLE

250 GAL SPOILS TANK	100 GAL WATER TANK	X" (INCHES), APPROX	WEIGHT, APPROX (LBS)
EMPTY	EMPTY	54"	3902
EMPTY	FULL (WATER)	48.5/8"	4736
FULL (WATER)	EMPTY	61.3/4"	5990
FULL (WATER)	FULL (WATER)	57"	6725

HYDRAULIC RESERVOIR FULL FUEL TANK FULL ANTI-FREEZE TANK FULL

MOUNTING HOLES
 11 X 1/2" GRADE 8 BOLTS &
 7 X 1/2" GRADE 8 BOLTS &
 REQUIRED FOR MOUNTING.
 SEE NOTE B

E.H. WACHS
 609 E. Highway 99, Suite 100
 Lewiston, ID 83201
 www.walcoinc.com

STANDARD X (GAS/VMS) (BH)	FORM	1.12
DATE	REV	01/22/2019
DATE	REV	04/22/2018
DATE	REV	02/02/2016
DATE	REV	01/22/2015
DATE	REV	01/22/2015
DATE	REV	01/22/2015
DATE	REV	01/22/2015
DATE	REV	01/22/2015

77-000-55

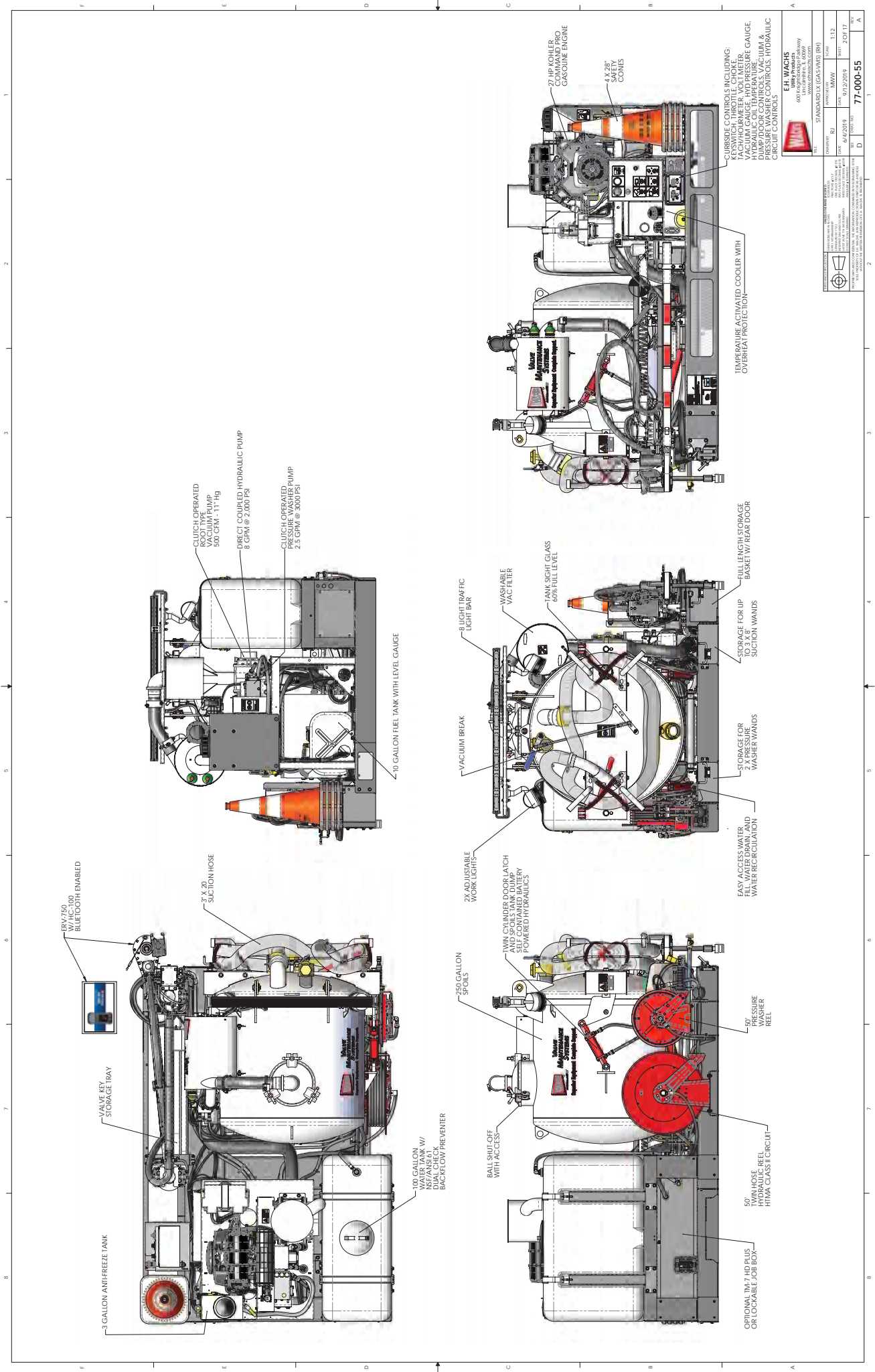

E.H. WACHS
 600 S. WILSON AVENUE
 WILSON, NJ 07094
 WWW.EHWACHS.COM

STANDARD X (GAS VARS) (BH)	FORM	112
REV	DATE	01/22/2019
REV	DATE	04/22/2019
REV	DATE	2/07/17
REV	DATE	05/05/00
77-000-55		

ITEM NO.	PART NUMBER	DESCRIPTION	ESTIMATE LENGTH	QTY.	ITEM NO.	PART NUMBER	DESCRIPTION	ESTIMATE LENGTH	QTY.
1	68-153-11	HANDLE CLEVIS ROD		1	54	77-290-44	LABEL, 100 GAL WATER TANK		1
2	68-158-16	HOSE CLAMP, CRIMP-23.9 - 27.1MM		5	55	77-290-46	LABEL, GWR WARNING		1
3	68-158-57	HOSE CLAMP, 3" SERIAL, CLOCKWISE		2	56	77-290-00	WELDMENT, VMS SKID RH CONTROLS		1
4	68-160-03	HOSE, 3" VACUUM - BLACK	(6.75FT)	1	57	77-291-01	WELDMENT, CONE HOLDER		1
5	68-195-50	HOSE REEL, REEL/CART, (3/8" X 100') BOTTOM WIND		1	58	77-291-28	28" TRAFFIC CONE		4
6	68-202-50	GD FLUG, 3/8" X 3/8" NPT F		1	59	77-292-12	151 5/16" HOSE ASSEMBLY, -08 FJ X -08 FJ X -08 HOSE		1
7	68-233-00	HOSE, 3/4" LP LOCK ON	(8 1/2') (10 1/2')	3	60	77-292-13	43 13/16" HOSE ASSEMBLY, -08 FJ X -08 FJ X -08 HOSE		1
8	68-236-00	STRIP, EPDM ADHESIVE BACKED FOAM RUBBER, 2" W X 1/4" THK	2x (9')	2	61	77-312-20	3" X 20" CLEAR SUCTION HOSE ASSEMBLY		1
9	68-236-00	STRIP, EPDM ADHESIVE BACKED FOAM RUBBER, 2" W X 1/4" THK	2x (20 1/2')	2	62	77-406-00	WASH DOWN WAND		1
10	68-242-51	DRAIN VALVE, 3/4" NPT FEMALE INLET X 3/4" MIGHT OUTLET		1	63	77-408-01	PRESSURE WASHER WAND, W/ROTATING NOZZLE		1
11	68-243-30	ADAPTER, 3/4" NPT M X 3/4" HOSE BARB - NYLON		3	64	77-413-04	ROLLER ASSEMBLY		3
12	68-243-30	ADAPTER, 3/4" NPT M X 3/4" HOSE BARB - NYLON		3	65	77-413-05	HYDRAULIC HOSE REEL KIT, BOTTOM ROLLER		1
13	68-243-70	HOSE TO CAM LEVER ADAPTER, 3/4" CAM M X 1/2" GHT F		1	66	77-420-00	LIGHT BAR KIT		1
14	68-243-71	CAM LEVER SOCKET, 3/4" X 3/4" NPT F		1	67	77-431-02-00	ASSEMBLY, 250 GAL SPOILS TANK		1
15	68-243-80	ADAPTER, 3/4 BARB X 3/4 NPT F		1	68	77-520-03-29	WIRE HARNESS, SKID POWER PACK		1
16	68-247-01	SNAP BUSHING, 1.38 ID X 1.75 HOLE X 1.25 PANEL		1	69	79-404-00	ERV-750 FOR VMS KIT		1
17	68-420-02	WAND WELDMENT, 7/8" X 8", 3" HOSE		1	70	79-422-01	HC-100 - VITALS CONTROLLER KIT - N-AMER		1
18	68-420-03	WAND WELDMENT, 1-1/4" X 8", 3" HOSE		1	71	90-045-04	NUT, 10-24 NYLOCK		18
19	68-420-04	WAND WELDMENT, 2-1/2" X 8", 3" HOSE		1	72	90-051-07	HHCS, 1/4-20 X 2 3/4 GRADE 5 Zn		12
20	77-162-63	100 GALLON WATER TANK ASSEMBLY		1	73	90-051-10	HHCS, 1/4-20 X 1		12
21	77-175-11	BUMPER, PUSH IN 1/4" HOLE		6	74	90-055-01	NUT, 1/4-20 HEX		2
22	77-209-02	CLAMP, 3.5" OD		1	75	90-055-18	NUT, 1/4-20 ACORN		13
23	77-209-04	U-BOLT, ZINC-PLATED STEEL, 1/4"-20, 1-1/8" ID, 2" HEIGHT		6	76	90-055-52	WASHER, 1/4 SPLIT RING		25
24	77-230-13	KIT, GAS SKID POWER PACK		1	77	90-055-53	WASHER, FLAT, 1/4"		25
25	77-235-94	LATCH CATCH		1	78	90-061-07	HHCS, 5/16-18 X 3/4		6
26	77-235-95	LATCH ASSY, RH		1	79	90-065-01	NUT, 5/16-18 HEX GRADE 8		6
27	77-256-95	LATCH ASSY, LH		2	80	90-065-51	WASHER, 5/16 SPLIT RING		6
28	77-276-11	DOUBLE CHECK VALVE, 3/4" NPT F X 3/4" NPT F		1	81	90-065-52	WASHER, 5/16 FLAT		6
29	77-277-50	PVC EDGE RING, 0.087 TO 0.190 EDGE THICKNESS	(2.34')	1	82	90-071-10	HHCS, 3/8-16 X 1		48
30	77-290-01	WATER TANK BASE WELDMENT		1	83	90-071-20	HHCS, 3/8-16 X 2 GR 5 ZN		4
31	77-290-02	WELDMENT, WATER TANK STAKE		4	84	90-075-01	NUT, 3/8-16 HEX GR 5 ZN		3
32	77-290-03	HOSE ROLLER GUIDE BRACKET		1	85	90-075-05	NUT, 3/8-16 NYLOCK GR 5 ZN		4
33	77-290-04	WELDMENT, BASKET SIDE		1	86	90-075-52	WASHER, 3/8 SPLIT RING		52
34	77-290-05	WELDMENT, LATCH BRACKET		1	87	90-075-53	WASHER, 3/8 FLAT		56
35	77-290-06	WAND HOLDER WELDMENT		1	88	90-078-84	ADAPTER, 3 (3/4" - 10) M X 3/8" NPT F 90		1
36	77-290-07	PRESSURE WASHER WAND HOLDER WELDMENT		1	89	90-091-12	HHCS, 1/2-13 X 1-1/4 GRADE 8		14
37	77-290-08	WELDMENT, DOOR SKID		2	90	90-095-15	NUT, 1/2-13 HEX GR 8 YELLOW ZINC		2
38	77-290-09	WELDMENT, BASKET DOOR		1	91	90-095-52	WASHER, 1/2 FLAT		14
39	77-290-11	WELDMENT, SUPPORT BRACKET		1	92	90-095-58	WASHER, 1/2 SPLIT RING		14
40	77-290-12	PPE SUPPORT BRACKET		2	93	90-140-07	SHCS, 10-24 X 3/4 SS18-8		18
41	77-290-13	PPE SUPPORT		2	94	90-218-15	TEE, 3/4 NPT POLY SCH 80		1
42	77-290-15	BASKET, BACK PANEL		1	95	90-218-18	NIPPLE, 3/4 NPT, 1 3/8 PVC SCH 80		1
43	77-290-16	COVER PLATE		2	96	90-903-10	CUSHIONED LOOP CLAMP, 1"		1
44	77-290-17	COVER PLATE		1	97	90-903-15	CUSHIONED LOOP CLAMP, 1 1/2"		5
45	77-290-18	COVER PLATE		1	98	90-903-20	CUSHIONED LOOP CLAMP, 2"		3
46	77-290-20	HOSE BRACKET		1	99	90-903-75	CUSHIONED LOOP CLAMP, 3/4"		3
47	77-290-21	BACK COVER PANEL		1	100	90-903-75	HHCS, 1/4-20 X 5/8" GR 5 ZN		28
48	77-290-22	SIDE COVER PANEL		1	101	90-1062-58	CLEVIS ROD END, 1/2-13"		2
49	77-290-24	WELDMENT, KEY BOX		1	102	90-1583K610	CLEVIS ROD END, 1/2-13"		2
50	77-290-28	STRAP, WATER TANK		2	103	90-6516M596	THREADED ROD, 1/2 X 13" X 24"		1
51	77-290-29	STAINLESS STEEL PIPE, 3/4" SCH 40		2	104	90-91327A168	BOLT, SHOULDER, 1/2 X 5/16 X SS		1
52	77-290-30	STAINLESS STEEL PIPE, 3/8" SCH 40		1	105	910-8-8-CTX-5	ELBOW, 1/2" M NPT X, 8 M JIC, (3/4" x 1/4")		1
53	77-290-31	LATCH CATCH		2					2

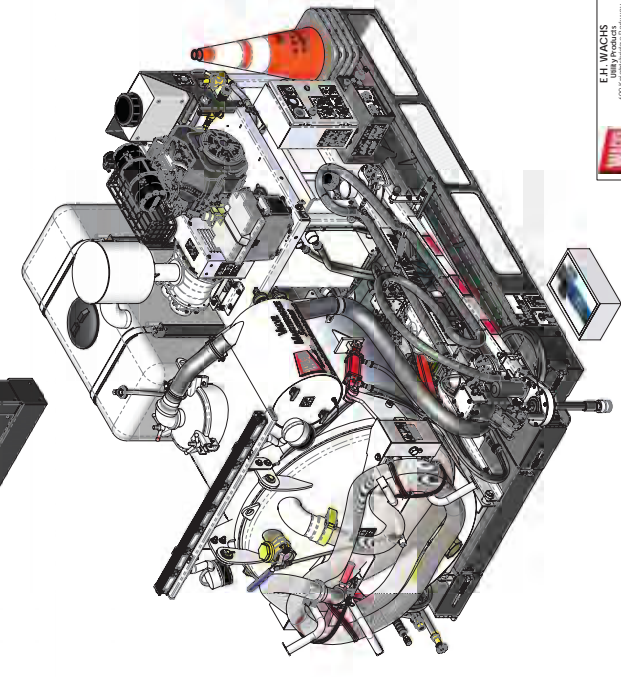
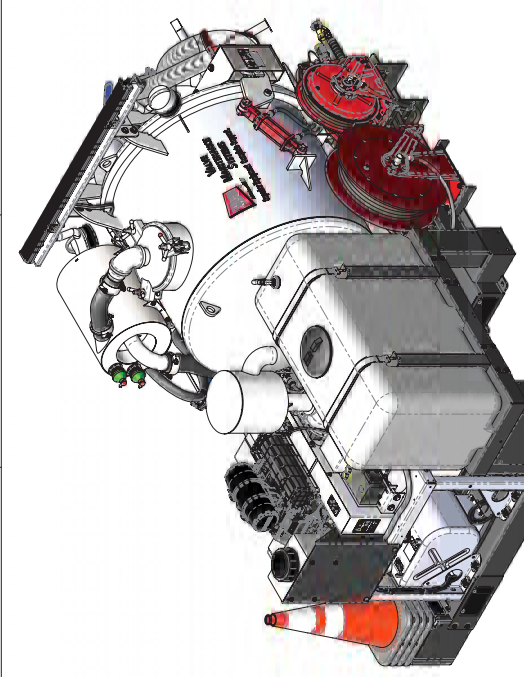

E.H. WACHS
 605 E. Highway 100
 Waco, TX 76788
 WWW.EHWACHS.COM

STANDARD LK (GAS-MS) (RH)

DATE: 04/28/18
 REV: 01/23/2019
 DRAWING NO: 77-000-55

REVISIONS

NO.	DATE	DESCRIPTION	BY	CHKD
1	01/23/2019	REVISED TO ADD PARTS	RL	112
2	01/23/2019	REVISED TO ADD PARTS	RL	112

APPROVED FOR CONSTRUCTION

DATE: 04/28/18

BY: RL

CHKD: 112

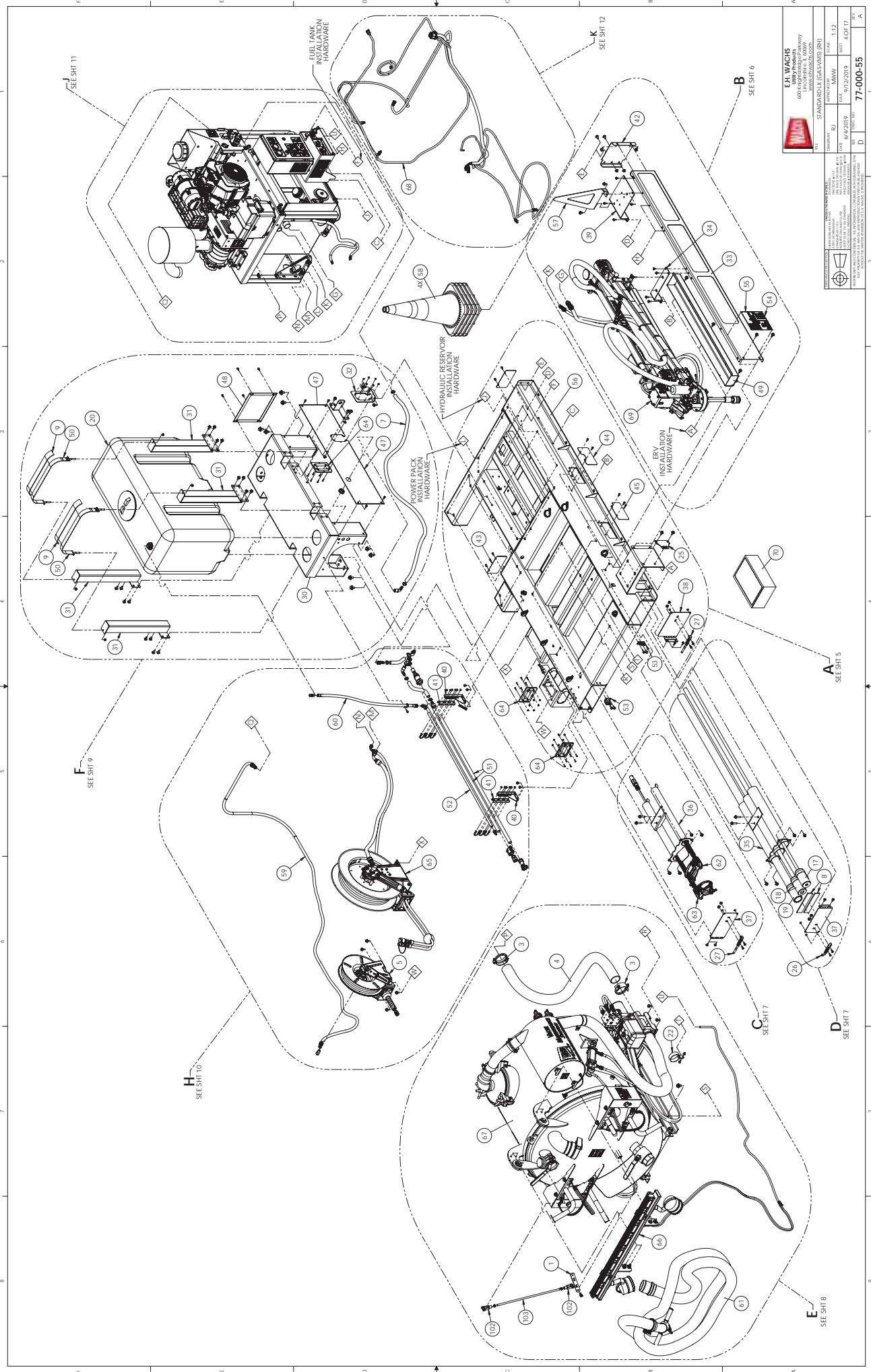

E.H. WACHS		STANDARD K (GAS VANS) (RH)	
600 N. HIGHTOWER AVENUE		DOWNEY, ILL. 60410	
TEL. (708) 439-1000		FAX (708) 439-1001	
WWW.EHWACHS.COM		WWW.EHWACHS.COM	
REV.	DATE	BY	CHK
001	01/22/2019	BL	112
002	04/28/2019	BL	40717
003	05/02/2020	BL	40717
D		77-000-55	

THIS DRAWING IS THE PROPERTY OF E.H. WACHS. IT IS TO BE USED ONLY FOR THE PURPOSES SPECIFIED HEREIN. IT IS NOT TO BE REPRODUCED, COPIED, OR TRANSMITTED IN ANY FORM OR BY ANY MEANS, ELECTRONIC OR MECHANICAL, INCLUDING PHOTOCOPYING, RECORDING, OR BY ANY INFORMATION STORAGE AND RETRIEVAL SYSTEM, WITHOUT THE WRITTEN PERMISSION OF E.H. WACHS.

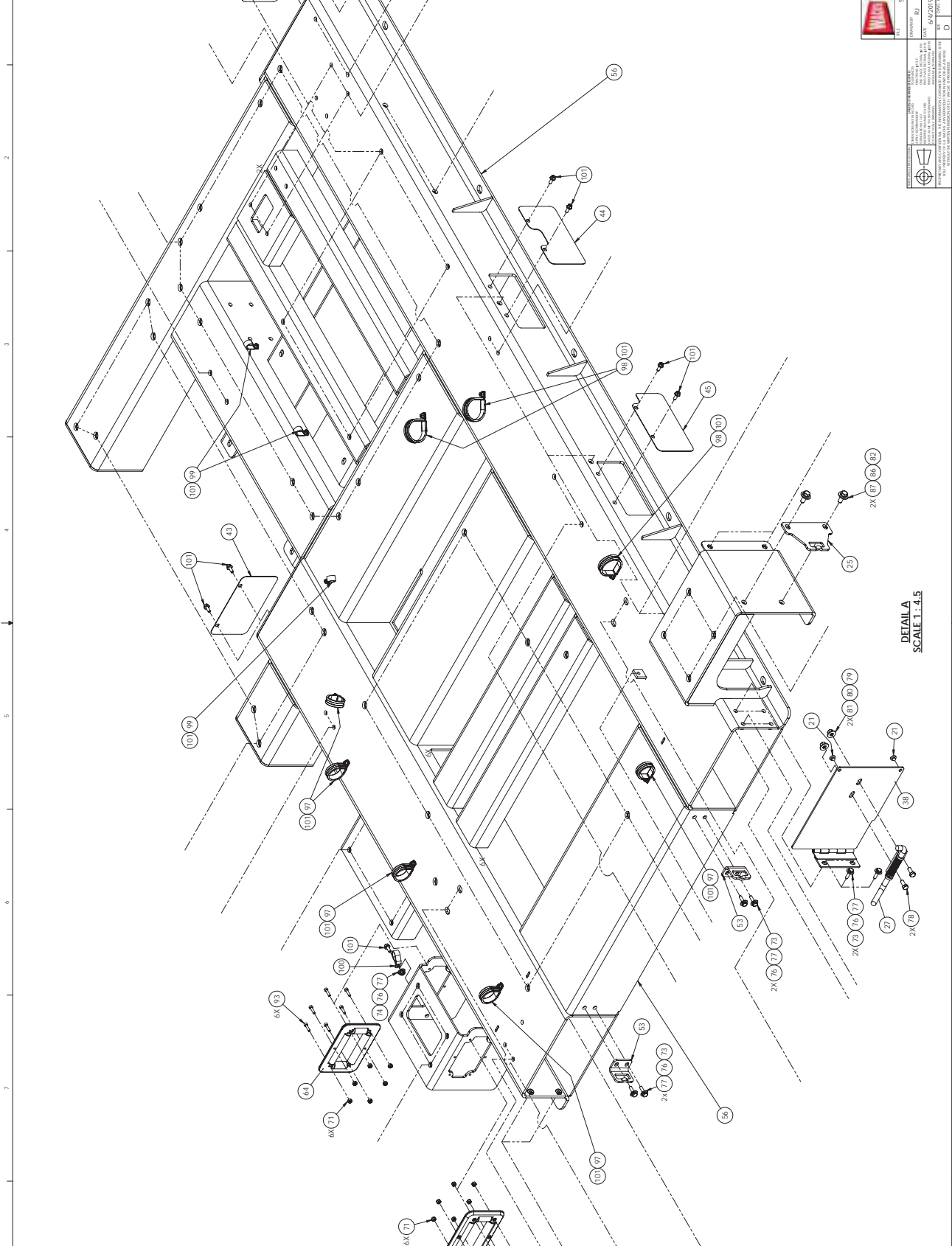

DETAIL A
SCALE 1:4.5

		E.H. WACHS 600 KENNEDY BOULEVARD ANN ARBOR MI 48106 PHONE: 734.769.1234 WWW.EHWACHS.COM	
PROJECT	STANDARD X (GAS VARS) (RH)	SCALE	1:3
DRAWING NO.	77-000-55	DATE	01/20/19
REV	0001	DATE	01/20/19
BY	0001	DATE	01/20/19
CHK	0001	DATE	01/20/19
APP	0001	DATE	01/20/19
DES	0001	DATE	01/20/19
DRG	0001	DATE	01/20/19
CON	0001	DATE	01/20/19
INT	0001	DATE	01/20/19
EXP	0001	DATE	01/20/19
CON	0001	DATE	01/20/19
INT	0001	DATE	01/20/19
EXP	0001	DATE	01/20/19

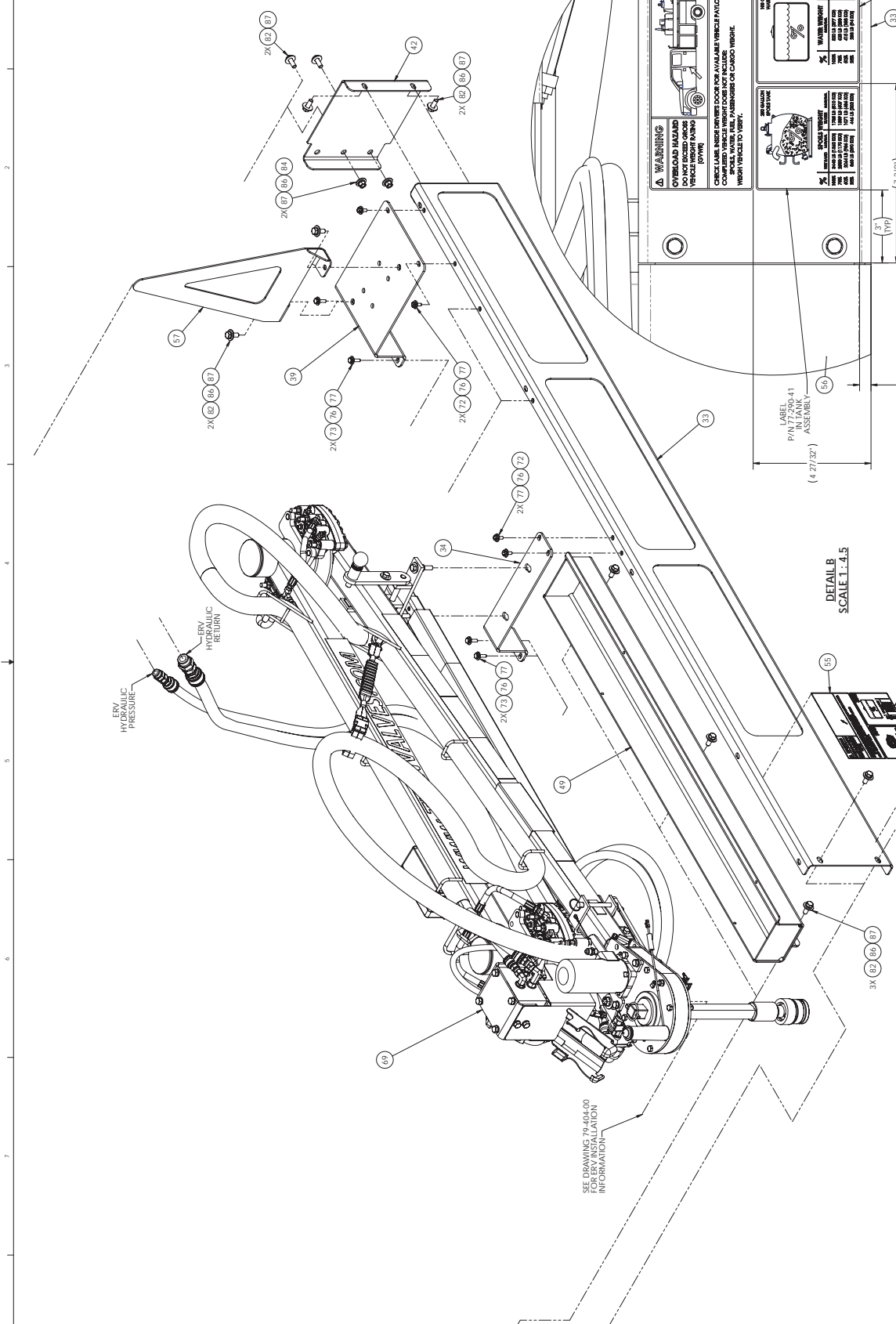

ERV
HYDRAULIC
PRESSURE

ERV
HYDRAULIC
RETURN

SEE DRAWING 79-404-00
FOR ERV INSTALLATION
INFORMATION

WARNING
OPERATOR MUST
DO NOT EXCEED OPER-
ATING CAPACITY OF
VEHICLE WEIGHT RATING
(GVWR)

CHECK LIFT RISE/LOWER DOOR FOR AVAILABLE VEHICLE WEIGHT.
DO NOT EXCEED OPERATING CAPACITY OF VEHICLE WEIGHT RATING (GVWR).
CHECK LIFT RISE/LOWER DOOR FOR AVAILABLE VEHICLE WEIGHT.
DO NOT EXCEED OPERATING CAPACITY OF VEHICLE WEIGHT RATING (GVWR).

MAXIMUM WEIGHT
DO NOT EXCEED
OPERATING CAPACITY
OF VEHICLE WEIGHT
RATING (GVWR).
DO NOT EXCEED
OPERATING CAPACITY
OF VEHICLE WEIGHT
RATING (GVWR).

MAXIMUM WEIGHT
DO NOT EXCEED
OPERATING CAPACITY
OF VEHICLE WEIGHT
RATING (GVWR).
DO NOT EXCEED
OPERATING CAPACITY
OF VEHICLE WEIGHT
RATING (GVWR).

LABEL
PART # 79-404-41
ASSEMBLY
(4.27/32")

DETAIL B
SCALE 1 : 4.5

(1.9/32")

▲ **SCALE AND WEIGHT LABEL**
VALUES SHOWN ON DRAWING
MAY DIFFER FROM ACTUAL.
SEE NOTE 9 ON SHEET 1

E.H. WACHS
600 E. Highway 100, Suite 100
Waco, TX 76788
www.ehwachs.com

REV	DATE	BY	CHKD
1	01/20/19	RL	I.A.
2	04/22/19	RL	I.A.
3	07/22/19	RL	I.A.
4	08/01/19	RL	I.A.
5	08/01/19	RL	I.A.
6	08/01/19	RL	I.A.
7	08/01/19	RL	I.A.
8	08/01/19	RL	I.A.
9	08/01/19	RL	I.A.
10	08/01/19	RL	I.A.
11	08/01/19	RL	I.A.
12	08/01/19	RL	I.A.
13	08/01/19	RL	I.A.
14	08/01/19	RL	I.A.
15	08/01/19	RL	I.A.
16	08/01/19	RL	I.A.
17	08/01/19	RL	I.A.
18	08/01/19	RL	I.A.
19	08/01/19	RL	I.A.
20	08/01/19	RL	I.A.
21	08/01/19	RL	I.A.
22	08/01/19	RL	I.A.
23	08/01/19	RL	I.A.
24	08/01/19	RL	I.A.
25	08/01/19	RL	I.A.
26	08/01/19	RL	I.A.
27	08/01/19	RL	I.A.
28	08/01/19	RL	I.A.
29	08/01/19	RL	I.A.
30	08/01/19	RL	I.A.
31	08/01/19	RL	I.A.
32	08/01/19	RL	I.A.
33	08/01/19	RL	I.A.
34	08/01/19	RL	I.A.
35	08/01/19	RL	I.A.
36	08/01/19	RL	I.A.
37	08/01/19	RL	I.A.
38	08/01/19	RL	I.A.
39	08/01/19	RL	I.A.
40	08/01/19	RL	I.A.
41	08/01/19	RL	I.A.
42	08/01/19	RL	I.A.
43	08/01/19	RL	I.A.
44	08/01/19	RL	I.A.
45	08/01/19	RL	I.A.
46	08/01/19	RL	I.A.
47	08/01/19	RL	I.A.
48	08/01/19	RL	I.A.
49	08/01/19	RL	I.A.
50	08/01/19	RL	I.A.
51	08/01/19	RL	I.A.
52	08/01/19	RL	I.A.
53	08/01/19	RL	I.A.
54	08/01/19	RL	I.A.
55	08/01/19	RL	I.A.
56	08/01/19	RL	I.A.
57	08/01/19	RL	I.A.
58	08/01/19	RL	I.A.
59	08/01/19	RL	I.A.
60	08/01/19	RL	I.A.
61	08/01/19	RL	I.A.
62	08/01/19	RL	I.A.
63	08/01/19	RL	I.A.
64	08/01/19	RL	I.A.
65	08/01/19	RL	I.A.
66	08/01/19	RL	I.A.
67	08/01/19	RL	I.A.
68	08/01/19	RL	I.A.
69	08/01/19	RL	I.A.
70	08/01/19	RL	I.A.
71	08/01/19	RL	I.A.
72	08/01/19	RL	I.A.
73	08/01/19	RL	I.A.
74	08/01/19	RL	I.A.
75	08/01/19	RL	I.A.
76	08/01/19	RL	I.A.
77	08/01/19	RL	I.A.
78	08/01/19	RL	I.A.
79	08/01/19	RL	I.A.
80	08/01/19	RL	I.A.
81	08/01/19	RL	I.A.
82	08/01/19	RL	I.A.
83	08/01/19	RL	I.A.
84	08/01/19	RL	I.A.
85	08/01/19	RL	I.A.
86	08/01/19	RL	I.A.
87	08/01/19	RL	I.A.
88	08/01/19	RL	I.A.
89	08/01/19	RL	I.A.
90	08/01/19	RL	I.A.
91	08/01/19	RL	I.A.
92	08/01/19	RL	I.A.
93	08/01/19	RL	I.A.
94	08/01/19	RL	I.A.
95	08/01/19	RL	I.A.
96	08/01/19	RL	I.A.
97	08/01/19	RL	I.A.
98	08/01/19	RL	I.A.
99	08/01/19	RL	I.A.
100	08/01/19	RL	I.A.

THIS LABEL
NOT IN THIS
ASSEMBLY
FROM

77-000-55

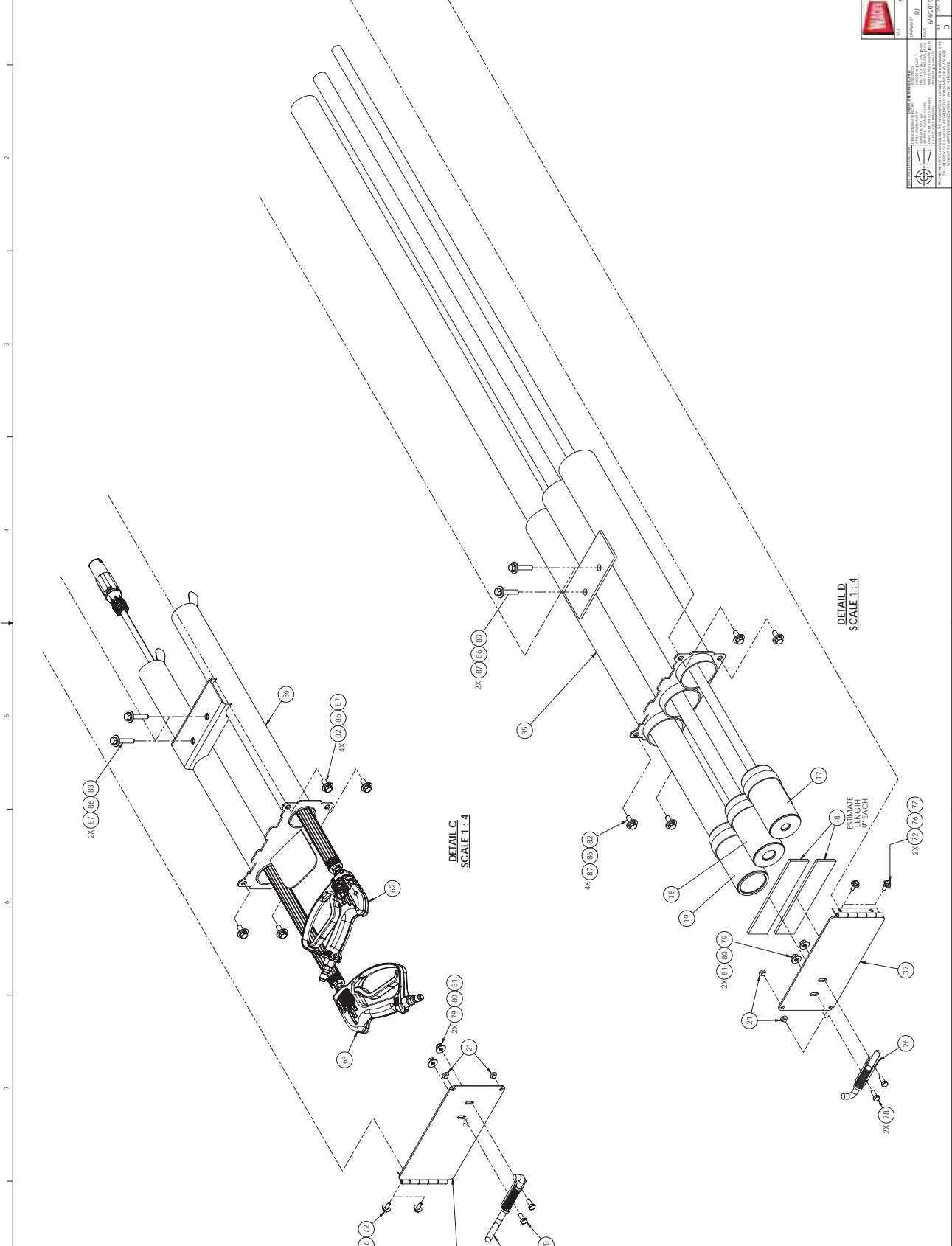

DETAIL SCALE 1:4

DETAIL SCALE 1:4

SMALLER LENGTH 9" EACH

DETAIL SCALE 1:4

DETAIL SCALE 1:4

DETAIL SCALE 1:4

DETAIL SCALE 1:4

DETAIL SCALE 1:4

DETAIL SCALE 1:4

DETAIL SCALE 1:4

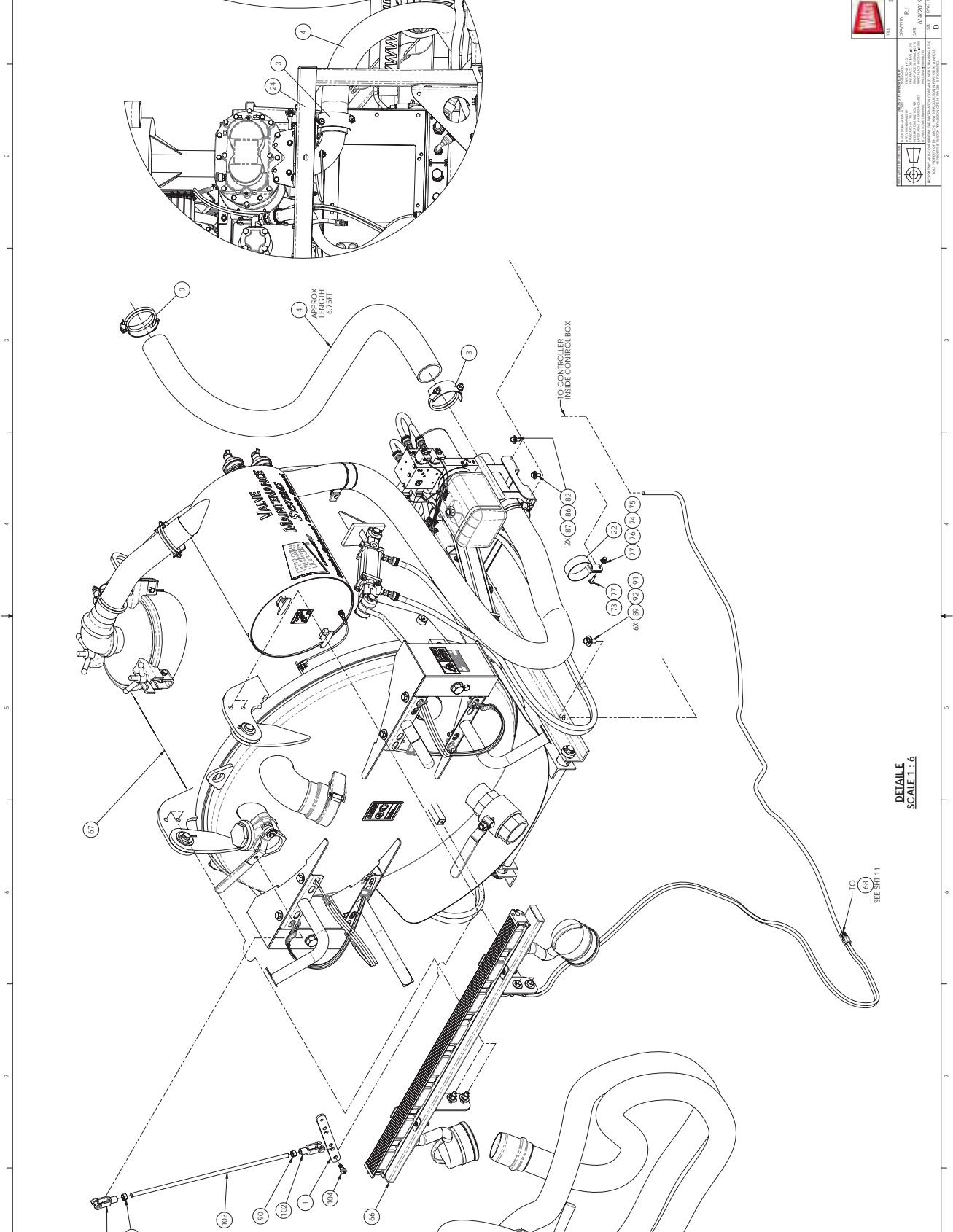

DETAIL
SCALE 1:6

		E.H. WACHS 600 KENTWOOD AVENUE WESTPORT, MASSACHUSETTS 01886 TEL: 978-335-1234 FAX: 978-335-1234 WWW.WALSH-SCBA.COM	
MODEL STANDARD X (GAS VARS) (BH)	SIZE I, II, III	DATE 01/22/2019	SHEET 001/17
DRAWING NO. 77-000-55	REV. 0001	DESIGNED BY (signature)	CHECKED BY (signature)

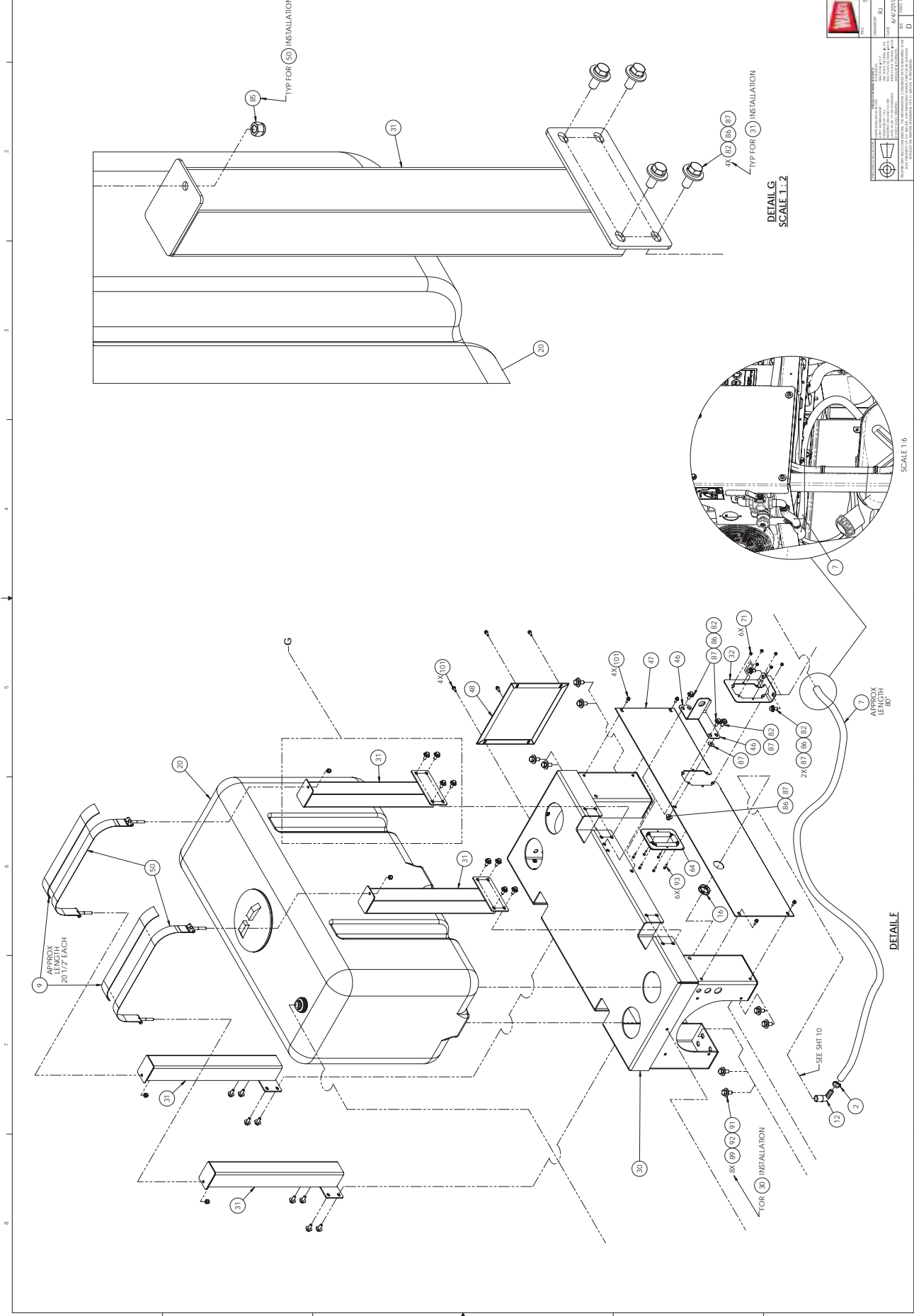

		E.H. WACHS 600 KENNEDY UNIVERSITY 1000 UNIVERSITY BLVD WASHINGTON, DC 20057 WWW.EHWACHS.COM	
STANDARD X (GAS/VMS) (BH)	SCALE 1:2	SHEET 17	TOTAL 17
DATE 01/22/2019	DRAWN BY	CHECKED BY	PROJECT
77-000-55	01/22/2019	01/22/2019	01/22/2019

APPROVED BY	DATE
APPROVED BY	DATE
APPROVED BY	DATE
APPROVED BY	DATE

APPROVED BY	DATE
APPROVED BY	DATE
APPROVED BY	DATE
APPROVED BY	DATE

APPROVED BY	DATE
APPROVED BY	DATE
APPROVED BY	DATE
APPROVED BY	DATE

APPROVED BY	DATE
APPROVED BY	DATE
APPROVED BY	DATE
APPROVED BY	DATE

APPROVED BY	DATE
APPROVED BY	DATE
APPROVED BY	DATE
APPROVED BY	DATE

APPROVED BY	DATE
APPROVED BY	DATE
APPROVED BY	DATE
APPROVED BY	DATE

APPROVED BY	DATE
APPROVED BY	DATE
APPROVED BY	DATE
APPROVED BY	DATE

APPROVED BY	DATE
APPROVED BY	DATE
APPROVED BY	DATE
APPROVED BY	DATE

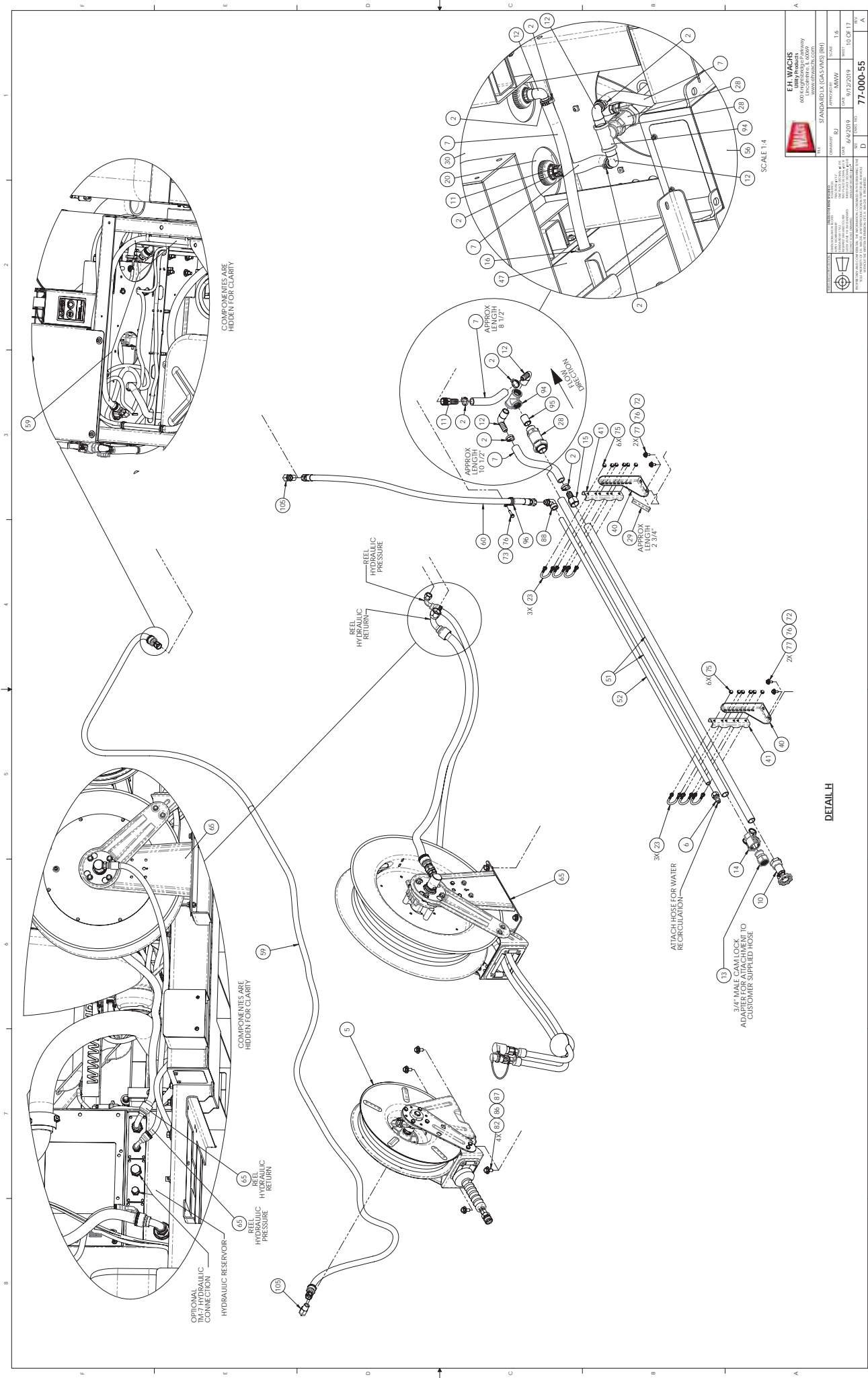

E.H. WACHS		STANDARD X (GAS VARS) (BH)	
600 N. Highway 100, Suite 100		Waco, TX 76780	
TEL: 817.870.0000		WWW.EHWACHS.COM	
REV	DATE	BY	CHK
1	01/22/2019	AW	IA
2	04/22/2019	AW	IA
3	05/02/2019	AW	IA
4	05/02/2019	AW	IA
5	05/02/2019	AW	IA
6	05/02/2019	AW	IA
7	05/02/2019	AW	IA
8	05/02/2019	AW	IA
9	05/02/2019	AW	IA
10	05/02/2019	AW	IA
11	05/02/2019	AW	IA
12	05/02/2019	AW	IA
13	05/02/2019	AW	IA
14	05/02/2019	AW	IA
15	05/02/2019	AW	IA
16	05/02/2019	AW	IA
17	05/02/2019	AW	IA
18	05/02/2019	AW	IA
19	05/02/2019	AW	IA
20	05/02/2019	AW	IA
21	05/02/2019	AW	IA
22	05/02/2019	AW	IA
23	05/02/2019	AW	IA
24	05/02/2019	AW	IA
25	05/02/2019	AW	IA
26	05/02/2019	AW	IA
27	05/02/2019	AW	IA
28	05/02/2019	AW	IA
29	05/02/2019	AW	IA
30	05/02/2019	AW	IA
31	05/02/2019	AW	IA
32	05/02/2019	AW	IA
33	05/02/2019	AW	IA
34	05/02/2019	AW	IA
35	05/02/2019	AW	IA
36	05/02/2019	AW	IA
37	05/02/2019	AW	IA
38	05/02/2019	AW	IA
39	05/02/2019	AW	IA
40	05/02/2019	AW	IA
41	05/02/2019	AW	IA
42	05/02/2019	AW	IA
43	05/02/2019	AW	IA
44	05/02/2019	AW	IA
45	05/02/2019	AW	IA
46	05/02/2019	AW	IA
47	05/02/2019	AW	IA
48	05/02/2019	AW	IA
49	05/02/2019	AW	IA
50	05/02/2019	AW	IA
51	05/02/2019	AW	IA
52	05/02/2019	AW	IA
53	05/02/2019	AW	IA
54	05/02/2019	AW	IA
55	05/02/2019	AW	IA
56	05/02/2019	AW	IA
57	05/02/2019	AW	IA
58	05/02/2019	AW	IA
59	05/02/2019	AW	IA
60	05/02/2019	AW	IA
61	05/02/2019	AW	IA
62	05/02/2019	AW	IA
63	05/02/2019	AW	IA
64	05/02/2019	AW	IA
65	05/02/2019	AW	IA
66	05/02/2019	AW	IA
67	05/02/2019	AW	IA
68	05/02/2019	AW	IA
69	05/02/2019	AW	IA
70	05/02/2019	AW	IA
71	05/02/2019	AW	IA
72	05/02/2019	AW	IA
73	05/02/2019	AW	IA
74	05/02/2019	AW	IA
75	05/02/2019	AW	IA
76	05/02/2019	AW	IA
77	05/02/2019	AW	IA
78	05/02/2019	AW	IA
79	05/02/2019	AW	IA
80	05/02/2019	AW	IA
81	05/02/2019	AW	IA
82	05/02/2019	AW	IA
83	05/02/2019	AW	IA
84	05/02/2019	AW	IA
85	05/02/2019	AW	IA
86	05/02/2019	AW	IA
87	05/02/2019	AW	IA
88	05/02/2019	AW	IA
89	05/02/2019	AW	IA
90	05/02/2019	AW	IA
91	05/02/2019	AW	IA
92	05/02/2019	AW	IA
93	05/02/2019	AW	IA
94	05/02/2019	AW	IA
95	05/02/2019	AW	IA
96	05/02/2019	AW	IA
97	05/02/2019	AW	IA
98	05/02/2019	AW	IA
99	05/02/2019	AW	IA
100	05/02/2019	AW	IA

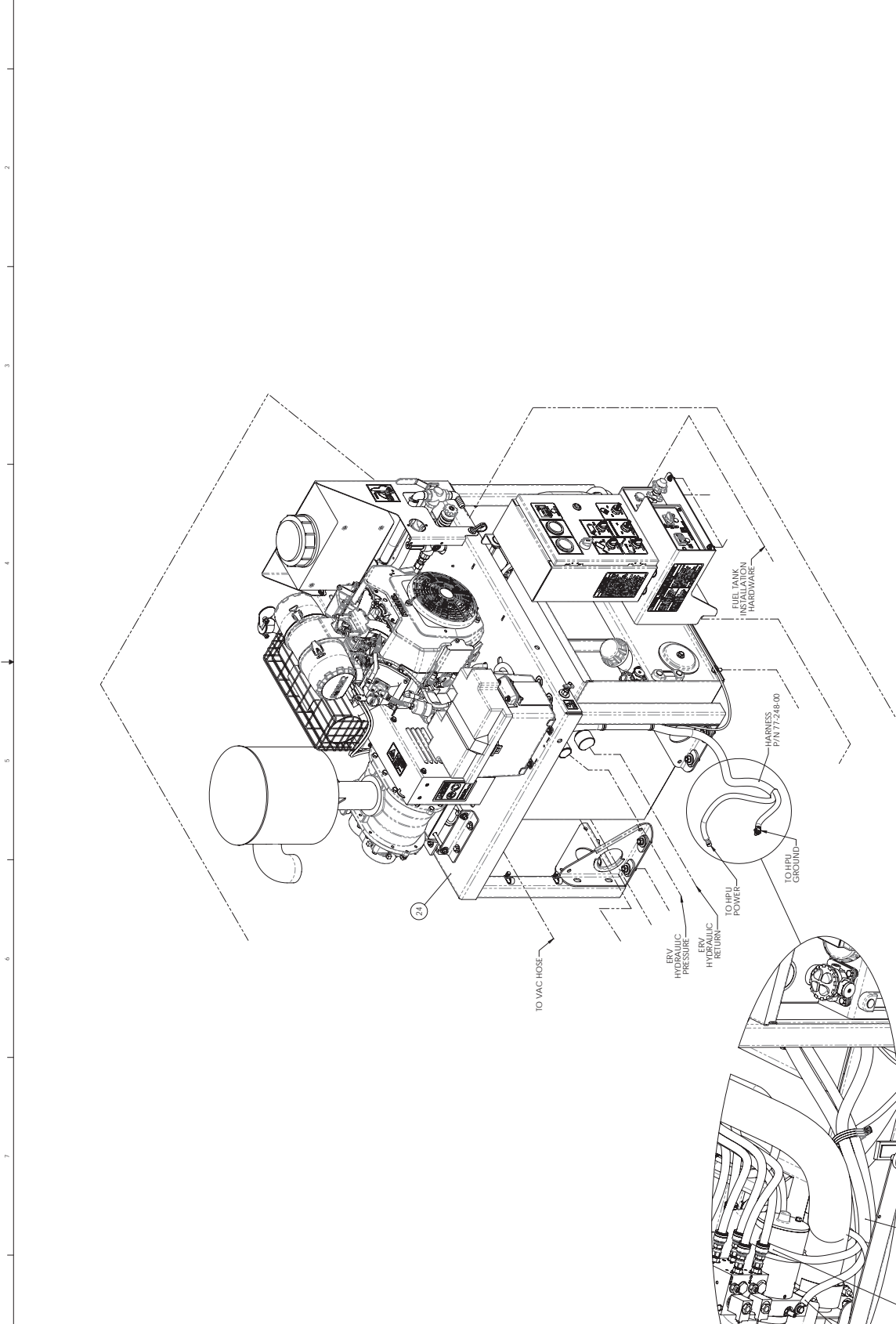

DETAIL J

		E.H. WACHS 609 E. Highway 100, Suite 100 Phoenix, AZ 85024 WWW.EHWACHS.COM	
TITLE: STANDARD X (GAS VMS) (RH)	DRAWING NO.: 77-000-55	DATE: 01/20/19	SCALE: 1:1
DESIGNED BY:	APPROVED BY:	DATE: 01/20/19	SHEET: 1 OF 1
DRAWN BY:	CHECKED BY:	DATE: 01/20/19	PART NO.:
PART NO.:	QTY:	UNIT:	Dwg No:

THIS DRAWING IS THE PROPERTY OF E.H. WACHS. IT IS TO BE USED ONLY FOR THE PROJECT AND QUANTITY SPECIFIED. IT IS NOT TO BE REPRODUCED OR TRANSMITTED IN ANY FORM OR BY ANY MEANS, ELECTRONIC OR MECHANICAL, INCLUDING PHOTOCOPYING, RECORDING, OR BY ANY INFORMATION STORAGE AND RETRIEVAL SYSTEM. E.H. WACHS ASSUMES NO LIABILITY FOR DAMAGES OF ANY KIND, INCLUDING CONSEQUENTIAL DAMAGES, ARISING FROM THE USE OF THIS DRAWING.

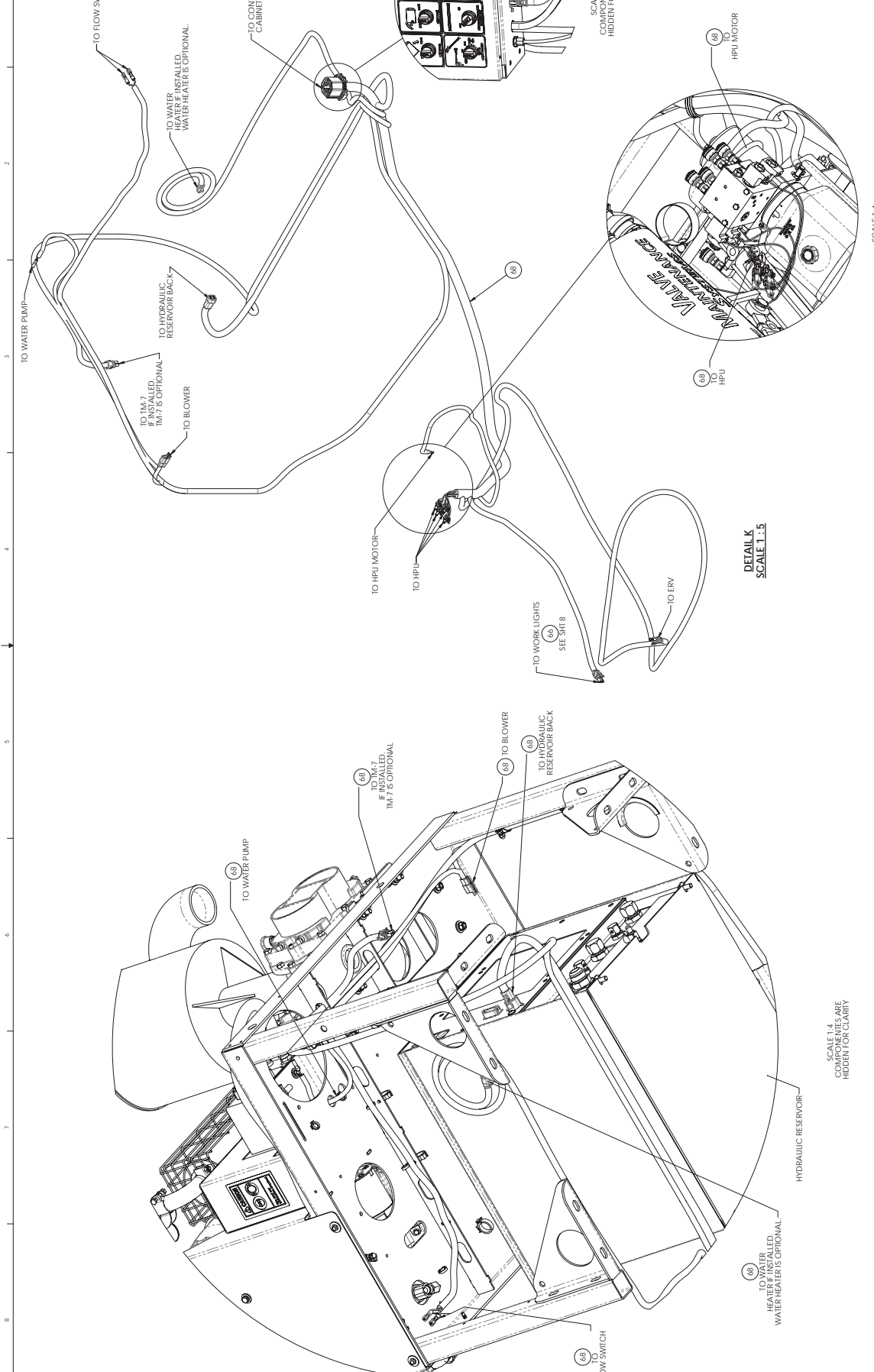

SCALE 1:4
COMPONENTS ARE HIDDEN FOR CLARITY

SCALE 1:4
COMPONENTS ARE HIDDEN FOR CLARITY

SCALE 1:4
COMPONENTS ARE HIDDEN FOR CLARITY

SCALE 1:5
COMPONENTS ARE HIDDEN FOR CLARITY

E.H. WACHS 6095 North Highway Mesa, AZ 85205 www.ehwachs.com		DATE	SCALE
REV	STANDARD X (GAS VARS) (BH)	REV	SCALE
1		01/22/2019	1:5
2		04/22/2019	1:5
3		07/02/2019	1:5
4		07/02/2019	1:5
5		07/02/2019	1:5
6		07/02/2019	1:5
7		07/02/2019	1:5
8		07/02/2019	1:5
77-000-55		D	

WACHS		DATE	SCALE
REV	STANDARD X (GAS VARS) (BH)	REV	SCALE
1		01/22/2019	1:5
2		04/22/2019	1:5
3		07/02/2019	1:5
4		07/02/2019	1:5
5		07/02/2019	1:5
6		07/02/2019	1:5
7		07/02/2019	1:5
8		07/02/2019	1:5
77-000-55		D	

WACHS		DATE	SCALE
REV	STANDARD X (GAS VARS) (BH)	REV	SCALE
1		01/22/2019	1:5
2		04/22/2019	1:5
3		07/02/2019	1:5
4		07/02/2019	1:5
5		07/02/2019	1:5
6		07/02/2019	1:5
7		07/02/2019	1:5
8		07/02/2019	1:5
77-000-55		D	

WACHS		DATE	SCALE
REV	STANDARD X (GAS VARS) (BH)	REV	SCALE
1		01/22/2019	1:5
2		04/22/2019	1:5
3		07/02/2019	1:5
4		07/02/2019	1:5
5		07/02/2019	1:5
6		07/02/2019	1:5
7		07/02/2019	1:5
8		07/02/2019	1:5
77-000-55		D	

WACHS		DATE	SCALE
REV	STANDARD X (GAS VARS) (BH)	REV	SCALE
1		01/22/2019	1:5
2		04/22/2019	1:5
3		07/02/2019	1:5
4		07/02/2019	1:5
5		07/02/2019	1:5
6		07/02/2019	1:5
7		07/02/2019	1:5
8		07/02/2019	1:5
77-000-55		D	

WACHS		DATE	SCALE
REV	STANDARD X (GAS VARS) (BH)	REV	SCALE
1		01/22/2019	1:5
2		04/22/2019	1:5
3		07/02/2019	1:5
4		07/02/2019	1:5
5		07/02/2019	1:5
6		07/02/2019	1:5
7		07/02/2019	1:5
8		07/02/2019	1:5
77-000-55		D	

WACHS		DATE	SCALE
REV	STANDARD X (GAS VARS) (BH)	REV	SCALE
1		01/22/2019	1:5
2		04/22/2019	1:5
3		07/02/2019	1:5
4		07/02/2019	1:5
5		07/02/2019	1:5
6		07/02/2019	1:5
7		07/02/2019	1:5
8		07/02/2019	1:5
77-000-55		D	

WACHS		DATE	SCALE
REV	STANDARD X (GAS VARS) (BH)	REV	SCALE
1		01/22/2019	1:5
2		04/22/2019	1:5
3		07/02/2019	1:5
4		07/02/2019	1:5
5		07/02/2019	1:5
6		07/02/2019	1:5
7		07/02/2019	1:5
8		07/02/2019	1:5
77-000-55		D	

WACHS		DATE	SCALE
REV	STANDARD X (GAS VARS) (BH)	REV	SCALE
1		01/22/2019	1:5
2		04/22/2019	1:5
3		07/02/2019	1:5
4		07/02/2019	1:5
5		07/02/2019	1:5
6		07/02/2019	1:5
7		07/02/2019	1:5
8		07/02/2019	1:5
77-000-55		D	

WACHS		DATE	SCALE
REV	STANDARD X (GAS VARS) (BH)	REV	SCALE
1		01/22/2019	1:5
2		04/22/2019	1:5
3		07/02/2019	1:5
4		07/02/2019	1:5
5		07/02/2019	1:5
6		07/02/2019	1:5
7		07/02/2019	1:5
8		07/02/2019	1:5
77-000-55		D	

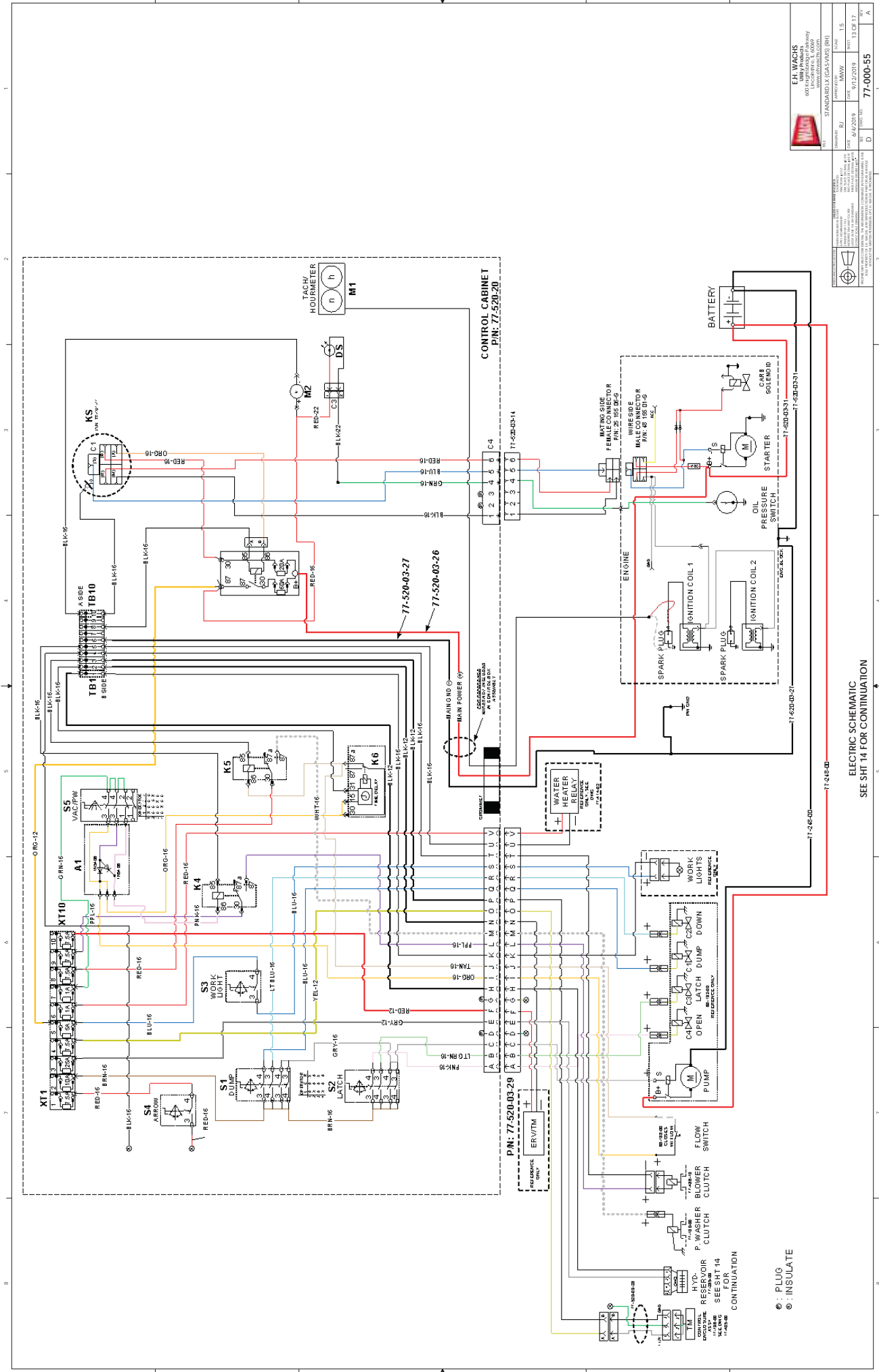

ELECTRIC SCHEMATIC
 SEE SHT 14 FOR CONTINUATION

● : PLUS
 ○ : INSULATE

CONTINUATION
 FOR SEE SHT-14
 CLUTCH
 BLOWER
 WASHER
 P. WASH
 HYD. RESERVOIR
 CONTROL VALVE
 TANK
 77-520-03-29

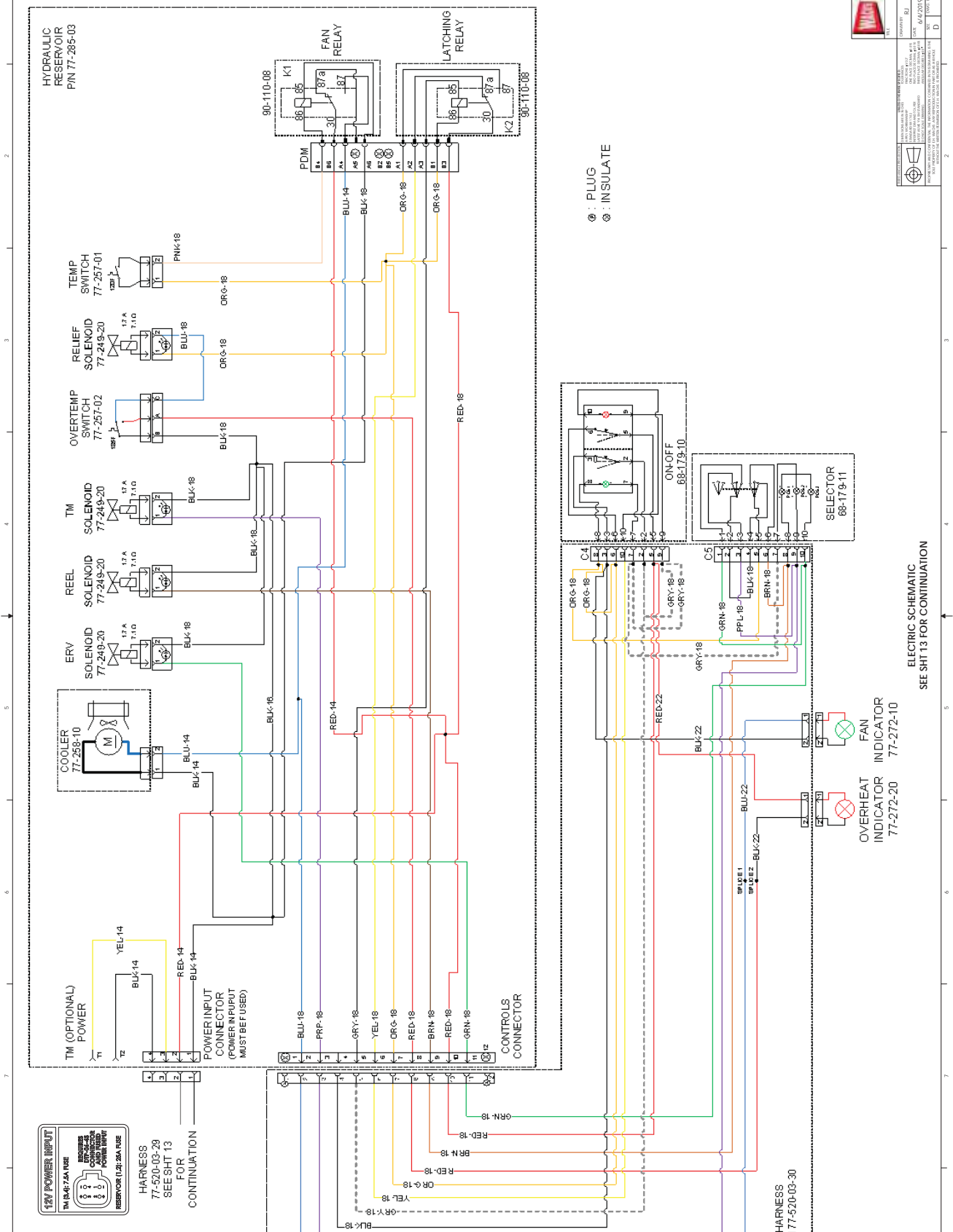

E.H. WACHS 600 N. HARRIS BLVD. MOUNTAIN VIEW, MO 64061 WWW.WACHS.COM		REV	STANDARD I.X. (GAS MARK) (R18)	FORM	1.5
DATE	APPROVED BY	REV	REV	DATE	DATE
01/20/2019	BL	01/20/2019	01/20/2019	01/20/19	01/20/19
04/28/2018	BL	04/28/2018	04/28/2018	04/28/18	04/28/18
02/02/2010	BL	02/02/2010	02/02/2010	02/02/10	02/02/10
77-000-55			D		

ELECTRIC SCHEMATIC
SEE SHT 13 FOR CONTINUATION

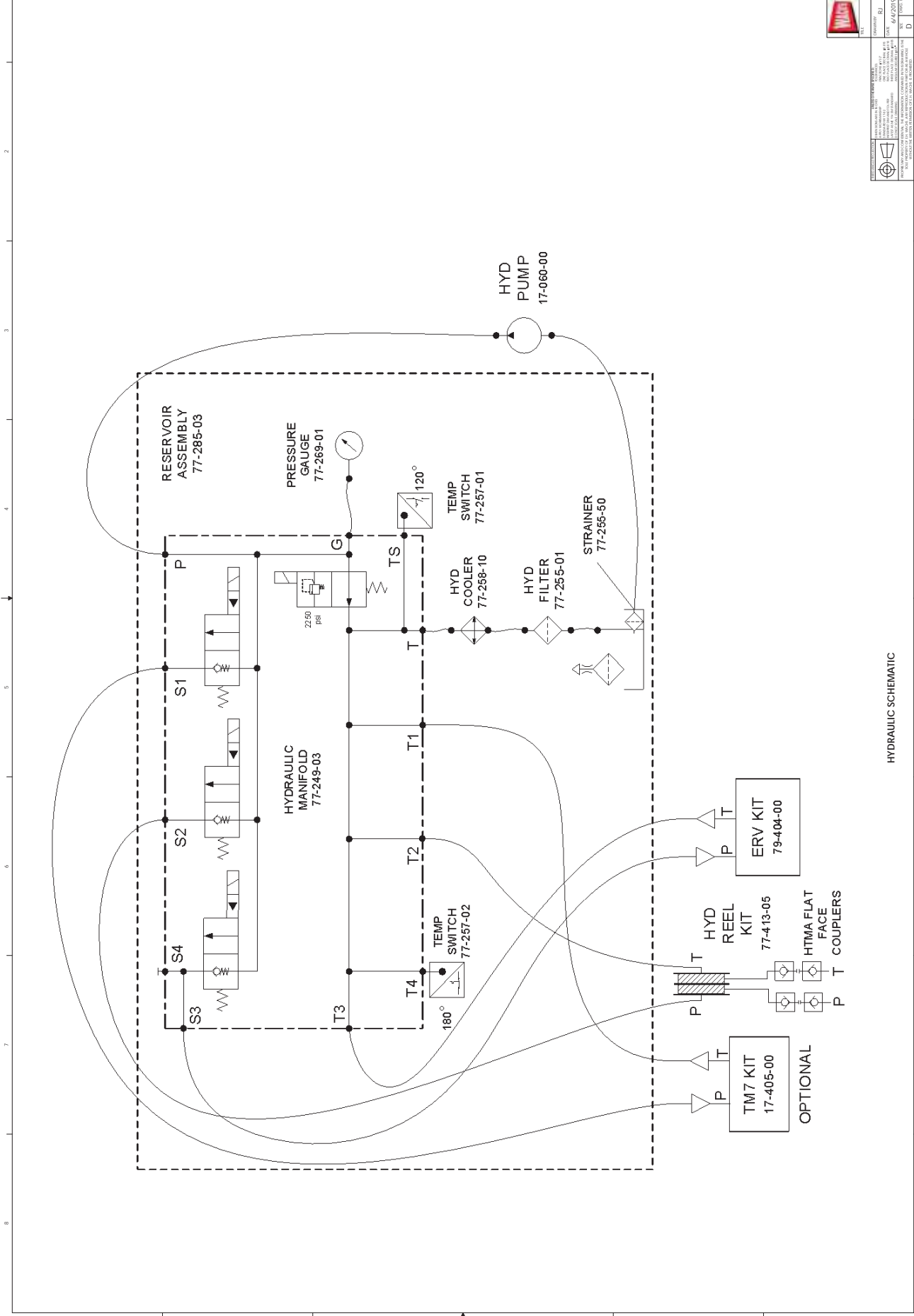

HYDRAULIC SCHEMATIC

		E.H. WACHS 600 N. Highway 100, Suite 100 Phoenix, AZ 85024 www.ehwachs.com	
DRAWING NO. 77-000-55	REV. D	DATE 01/20/19	DESIGNED BY JL
CHECKED BY RL	APPROVED BY RL	SCALE 1:1	SHEET NO. 15 OF 15

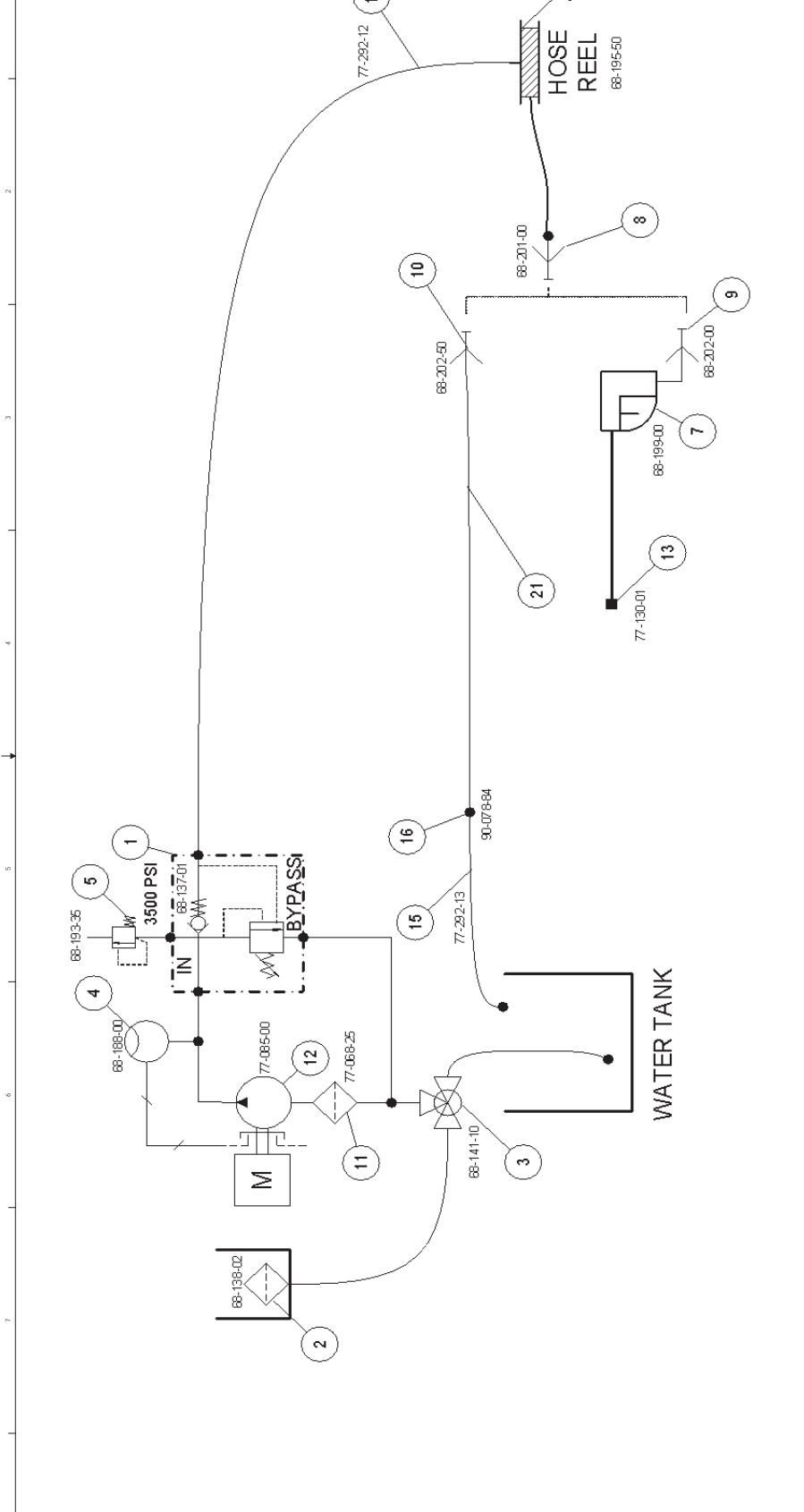

PARTS LIST FOR PRESSURE WASHER SYSTEM SCHEMATICS. REFERENCE ONLY. BALLOONS DO NOT CORRESPOND WITH ROW TABLE ON SHEET 3

SCHEMATIC ITEM	PART NUMBER	DESCRIPTION
1	68-138-01	VALVE, TRAPPED PRESSURE UNLOADER
2	68-138-02	STRAINER
3	68-141-10	BALL VALVE, 3-WAY
4	68-188-00	FLOW SWITCH
5	68-192-35	SAFETY RELIEF, 3500 PSI
6	68-195-50	HOSE REEL
7	68-199-00	SPRAY GUN
8	68-201-00	OD COUPLER, 3/8" X 3/8" NPT-F
9	68-202-00	OD PLUG, 3/8" X 3/8" NPT-M
10	68-202-50	OD PLUG, 3/8" X 3/8" NPT-F
11	77-069-25	STRAINER
12	77-085-00	PUMP PRESSURE WASHER 2.6 GPM, 3000 PSI
13	77-130-01	NOZZLE, .030 X 15 DEGREE
14	77-292-12	151 5/16" HOSE ASSEMBLY, .08 E.I. X .08 F.I. X .08 HOSE
15	77-292-13	43 13/16" HOSE ASSEMBLY, .08 E.I. X .08 F.I. X .08 HOSE
16	90-076-84	ADAPTER, 8 (3/4" - 1.625) X 3/8" NPT-F 90

PRESSURE WASHER SYSTEM SCHEMATIC

E.H. WACHS
600 N. WILSON AVENUE
MILWAUKEE, WI 53212
WWW.EHWACHS.COM

REV	STANDARD LX (GAS/MRS) (RH)	SCALE	1:12
DATE	01/20/2019	DESIGNED BY	RL
DATE	04/20/18	ISSUED BY	RL
DATE	02/02/10	REVISED BY	RL
DATE	02/02/10	REVISED BY	RL

77-000-55

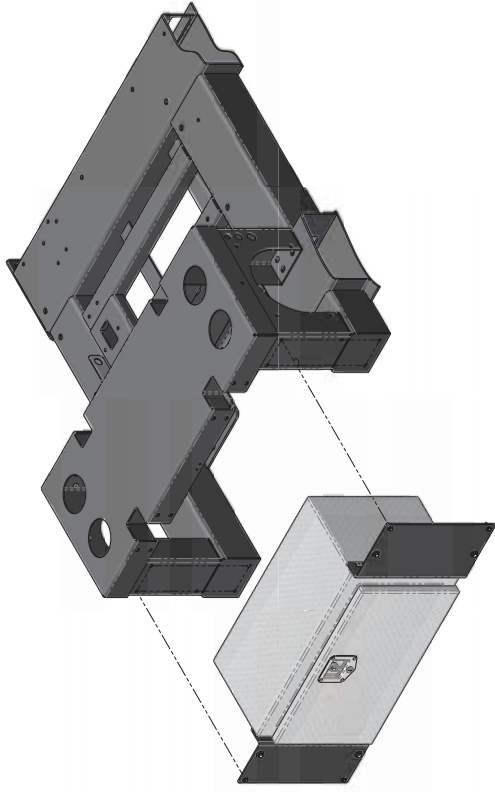

P/N 77-409-00
JOB BOX FOR VMS KIT
NOT AVAILABLE WITH TM-7

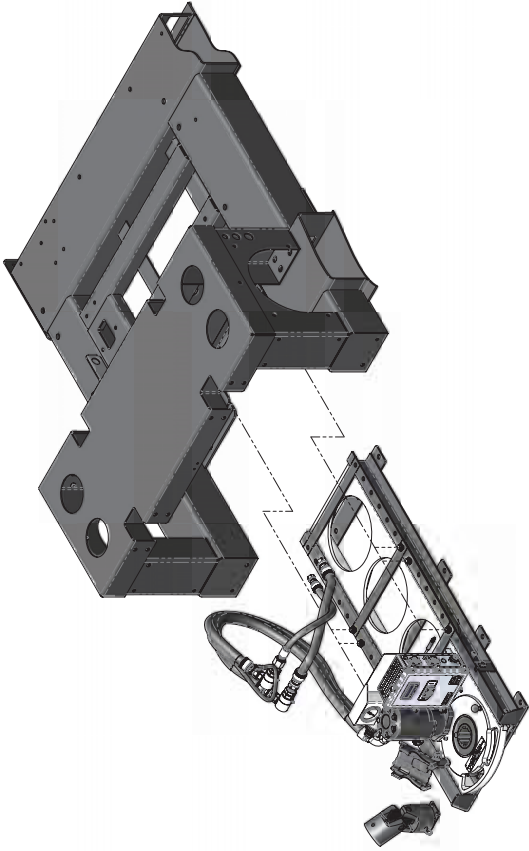

P/N 77-406-00
TM-7 HD PLUS FOR VMS KIT,
NOT AVAILABLE WITH JOB BOX

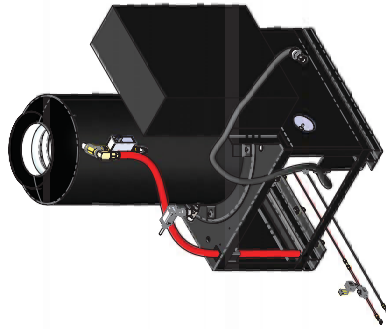

P/N 77-414-02
WATER HEATER - VMS KIT

AVAILABLE OPTIONS

 E.H. WACHS 600 E. Highway 101, Suite 100 Waco, TX 76798 www.ehwachs.com		STANDARD X (GAS/VMS) (BH)	
DRAWING NO. 77-000-55	REV. 01/20/19	SCALE 1:1	SHEET 1 OF 1
DATE 01/20/19	DESIGNED BY	CHECKED BY	APPROVED BY
DESIGNED BY	CHECKED BY	APPROVED BY	DATE

NOTES:

1. VIEWS SHOW OPTIONAL EQUIPMENT:

- ERV-750 WITH BLUECOOH KIT: P/N 77-404-00
- POWER PACK WITH HYDRAULICS KIT: P/N 77-260-13
- SERVICE LIGHT PACKAGE: P/N 77-400-00
- HC-100 VITALS CONTROLLER KIT: P/N 77-422-01
- HC-100 VITALS CONTROLLER KIT: P/N 77-422-01

3 GALLON ANTI-FREEZE TANK

VALVE KEY STORAGE TRAY

OPTIONAL HC-100 VITALS CONTROLLER KIT: P/N 77-422-01

OPTIONAL ERV-750 WITH BLUECOOH KIT: P/N 77-404-00

3/4" O.D. SUCTION HOSE

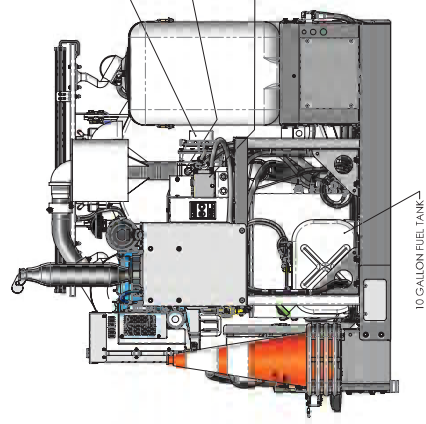

10 GALLON FUEL TANK

CLUTCH OPERATED VACUUM PUMP 500 CFM - 11" Hg

DIRECT COUPLED HYDRAULIC PUMP 1000 CFM ONLY WITH OPTIONAL HYDRAULIC POWER PACK (P/N 77-260-13)

CLUTCH OPERATED PRESSURE WASHER PUMP 2.5 CFM @ 3000 PSI

OPTIONAL 150 GAL SPOILS TANK: P/N 77-433-02

OPTIONAL 250 GAL SPOILS TANK: P/N 77-433-02-50 (SHOWN)

OPTIONAL 350 GAL SPOILS TANK: P/N 77-433-02-50

100 GALLON WATER TANK W/ DUAL CHECK BACKFLOW PREVENTER

2X ADJUSTABLE WORK LIGHTS

OPTIONAL SERVICE LIGHT PACKAGE: P/N 77-400-00

TWIN CYLINDER DOOR LATCH SELF-CONTAINED BATTERY POWERED HYDRAULICS

8 LIGHT TRAFFIC LIGHT BAR, ONLY WITH OPTIONAL HYDRAULIC KIT: P/N 77-420-00

WASHABLE VAC FILTER

TANK SIGHT GLASS 60% FULL LEVEL

VACUUM BREAK

45° BRASS FOR 2" X 3" SUCTION WANDS

BULL LENGTH STORAGE BASKET W/ REAR DOOR

OPTIONAL HYDRAULIC HOSE REEL KIT: 50' TWIN HOSE HYDRAULIC REEL WITH 1/2" DIA. COILS & CIRCUIT

50' PRESSURE REEL

BALL SHUT-OFF WITH ACCESS

OPTIONAL IN-7 HD PLUS KIT: P/N 77-405-00 OR LOCKABLE JOB BOX KIT: P/N 77-405-00

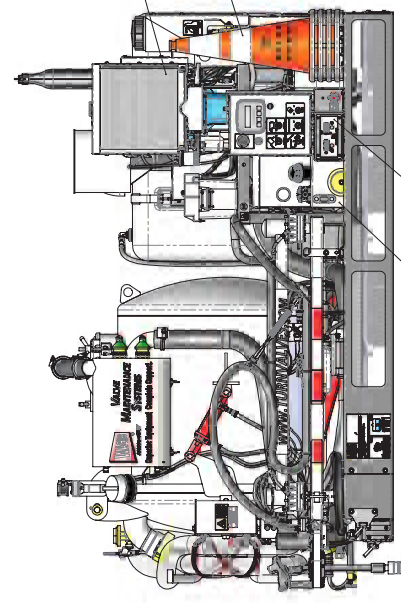
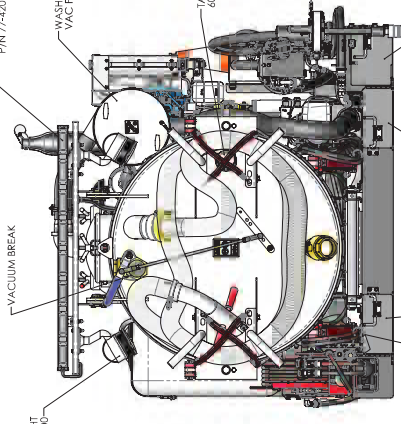

24.8 HP KUBOTA COOLED DIESEL ENGINE

4 X 28" SAFETY CONES

OPTIONAL TEMPERATURE ACTIVATED COOLER WITH OVERHEAT PROTECTION KIT: P/N 77-260-13

OPTIONAL TEMPERATURE ACTIVATED COOLER WITH OVERHEAT PROTECTION KIT: P/N 77-260-13

CURBSIDE CONTROLS AVAILABLE WITH OPTIONAL POWER PACK WITH HYDRAULICS KIT P/N 77-260-13 INCLUDING: TACHOMETER, VOLT METER, FUEL LEVEL GAUGE, VACUUM GAUGE, HPD PRESSURE GAUGE, DUMP/DOOR CONTROLS, VACUUM & CIRCUIT CONTROLS, HYDRAULIC CIRCUIT CONTROLS

E.H. WACHS 6050 Kingsbridge Parkway Dallas, TX 75248 WWW.WACHS.COM	
KIT: STANDARD BUILDER (DIESEL-IMV) (RH)	Model: 77-000-60
Manufacturer: WACHS	Serial: 132
Date: 8/20/19	Date: 2/2/17
Rev: 000001	Rev: 000001

NOTES:

- 1. VIEWS SHOW OPTIONAL EQUIPMENT.
- 2. ERY-750 WITH BLUE TOOTH KIT: P/N 77-604-00
- 3. 25 GAL. 5 PALS TANK: P/N 77-431-00-00
- 4. HYDRAULIC HOSE REEL KIT: P/N 77-431-00-00
- 5. SERVICE LIGHT PACKAGE: P/N 77-400-00
- 6. HC-100 MPALS CONTROLLER KIT: P/N 77-442-01

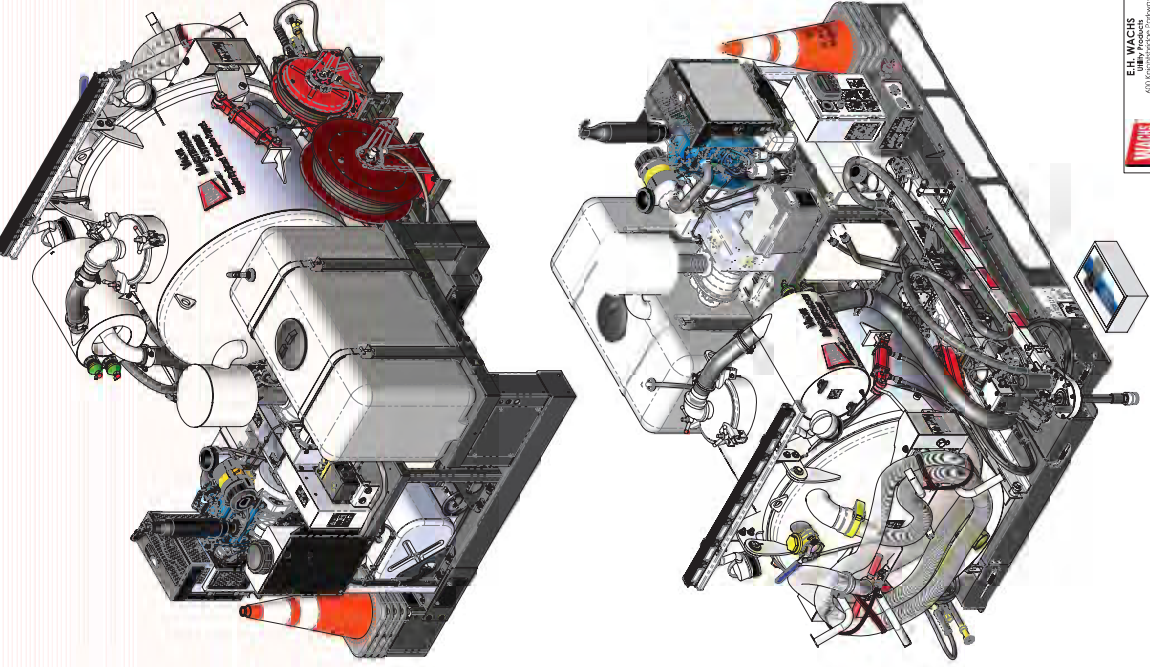

ITEM NO.	PART NUMBER	DESCRIPTION	ESTIMATE LENGTH	QTY.
45	77-290-18	COVER PLATE		1
46	77-290-20	HOSE BRACKET		1
47	77-290-21	BACK COVER PANEL		1
48	77-290-22	SIDE COVER PANEL		1
49	77-290-24	WELDMENT KEY BOX		1
50	77-290-26	STRAP WATER TANK		2
51	77-290-29	STAINLESS STEEL PIPE, 3/8" SCH 40		2
52	77-290-30	STAINLESS STEEL PIPE, 3/8" SCH 40		1
53	77-290-31	LATCH CATCH		2
54	77-290-44	LABEL, 100 GAL WATER TANK		1
55	77-290-46	LABEL, GWR WARNING		1
56	77-290-00	WELDMENT, VMS SHD RH CONTROLS		1
57	77-291-01	WELDMENT, CONE HOLDER		1
58	77-291-28	28" TRAFFIC CONE		4
59	77-292-12	1.51 5/16" HOSE ASSEMBLY, -08 FJ X -08 FJ X -08 HOSE		1
60	77-292-13	43 13/16" HOSE ASSEMBLY, -08 FJ X -08 FJ X -08 HOSE		1
61	77-312-20	3" X 20' CLEAR SUCTION HOSE ASSEMBLY		1
62	77-400-00	WASH DOWN WAND		1
63	77-408-01	PRESSURE WASHER WAND, W/ROTATING NOZZLE		1
64	77-413-04	ROLLER ASSEMBLY		3
65	77-500-03-29	WIRE HARNESS, SKID POWER PACK		1
66	90-045-04	NUT, 10-24 NYLOCK		18
67	90-051-07	HHCS, 1/4-20 X 3/4 GRADE 5.2n		12
68	90-051-10	HHCS, 1/4-20 X 1		12
69	90-053-01	NUT, 1/4-20 HEX		2
70	90-055-18	NUT, 1/4-20 ACORN		13
71	90-055-52	WASHER, 1/4 SPIRIT RING		25
72	90-055-53	WASHER, FLAT, 1/4		25
73	90-061-07	HHCS, 5/16-18 X 3/4		6
74	90-065-01	NUT, 5/16-18 HEX GRADE 8		6
75	90-065-51	WASHER, 5/16 SPIRIT RING		6
76	90-065-52	WASHER, 5/16 FLAT		6
77	90-071-10	HHCS, 3/8-18 X 1		48
78	90-071-20	HHCS, 3/8-18 X 2 GR 5 ZN		4
79	90-075-01	NUT, 3/8-16 HEX GR 5 ZN		3
80	90-075-03	NUT, 3/8-16 NYLOCK GR 5 ZN		4
81	90-075-52	WASHER, 3/8 SPIRIT RING		52
82	90-075-53	WASHER, 3/8 FLAT		56
83	90-078-84	ADAPTER, -8 (3/4" - 1.6") M/J X 3/8" NPT-F 90		1
84	90-091-12	HHCS, 1/2-13 X 1-1/4 GRADE 8		14
85	90-095-13	NUT, 1/2-13 HEX GR 8 YELLOW ZINC		2
86	90-095-52	WASHER, 1/2 FLAT		14
87	90-095-58	WASHER, 1/2 SPIRIT RING		14
88	90-140-07	SHCS, 10-24 X 3/4 S5.18-8		18
89	90-218-15	TEE, 3/4 NPT POLY SCH 80		1
90	90-218-18	NIPPLE, 3/4 NPT, 1.3/8 PVC SCH 80		1
91	90-802-10	CUSHIONED LOOP CLAMP, 1"		1
92	90-803-15	CUSHIONED LOOP CLAMP, 1 1/2"		5
93	90-803-20	CUSHIONED LOOP CLAMP, 2"		3
94	90-803-25	CUSHIONED LOOP CLAMP, 3/4"		3
95	90-803-25	CUSHIONED LOOP CLAMP, 3/4"		1
96	90-1002-58	HHFS, 1/4-20 X 5/8" GR 5 ZN		28
97	90-1883-10	CLEMS ROD END, 1/2-13"		2
98	90-651-8856	THREADED ROD, 1/2-13" X 24"		1
99	90-91337-1-68	BOIL SHOULDER, 1/2 X 5/16 X 5.5		1
100	910-8-8-CTVS-5	ELBOW, 1/2" M NPT X 8-M JIC (3/4"-1.6)		2

ITEM NO.	PART NUMBER	DESCRIPTION	ESTIMATE LENGTH	QTY.
1	68-153-11	HANDLE CLEVIS ROD		1
2	68-158-16	HOSE CLAMP, CRIMP-23.9-27.1 MM		5
3	68-158-57	HOSE CLAMP, 3" SPIRAL, CLOCKWISE		2
4	68-160-03	HOSE, 3" VACUUM - BLACK (6.78FT)		1
5	68-195-30	WATER HOSE REEL, REELCRAFT, (8'8" X 50') BOTTOM WIND		1
6	68-201-00	GD. COUPLER, 3/8" X 3/8" NPT-F		1
7	68-202-50	GD. PLUG, 3/8" X 3/8" NPT-F		1
8	68-233-00	HOSE, 3/4" LP LOCK ON	(8 1/2') (10 1/2') (80')	3
9	68-234-00	STRIP, EPDM ADHESIVE BACKED FOAM RUBBER, 2" W X 1/4" THK	2X (7')	2
10	68-234-00	STRIP, EPDM ADHESIVE BACKED FOAM RUBBER, 2" W X 1/4" THK	2X (20 1/2')	2
11	68-242-51	DRAIN VALVE, 3/4" NPT FEMALE INLET X 3/4" MIGHT OUTLET		1
12	68-243-20	ADAPTER, 3/4" NPT M X 3/4" HOSE BARB - NYLON		1
13	68-243-30	ELBOW, 3/4" NPT M X 3/4" HOSE BARB - NYLON		3
14	68-243-70	HOSE TO CAM LEVER ADAPTER, 3/4" CAM MAX GHF		1
15	68-243-71	CAM LEVER SOCKET, 3/4" X 3/4" NPTF		1
16	68-243-80	ADAPTER, 3/4" BARB X 3/4" NPTF		1
17	68-247-01	SNAP BUSHING, 1.38 ID X 1.75 HOLE X .125 PANEL		1
18	68-400-02	WAND WELDMENT, 7/8" X 8", 3" HOSE		1
19	68-400-03	WAND WELDMENT, 1 1/4" X 8", 3" HOSE		1
20	68-400-04	WAND WELDMENT, 2 1/4" X 8", 3" HOSE		1
21	77-162-63	100 GALLON WATER TANK ASSEMBLY		1
22	77-175-11	BUMPER PUSH-IN 1/4" HOLE		6
23	77-209-02	CLAMP, 3.5" OD		1
24	77-209-04	U-BOLT, ZINC PLATED STEEL, 1/4"-20, 1-1/8" ID, 2" HEIGHT		6
25	77-235-94	LATCH CATCH		1
26	77-235-95	LATCH ASSY, RH		1
27	77-234-95	LATCH ASSY, LH		2
28	77-274-11	DOUBLE CHECK VALVE, 3/4" NPT-F X 3/4" NPT-F		1
29	77-277-50	PVC EDGE TRIM, 0.090 TO 0.190 EDGE THICKNESS	(2 3/4')	1
30	77-290-01	WATER TANK BASE WELDMENT		1
31	77-290-02	WELDMENT, WATER TANK STAKE		4
32	77-290-03	HOSE ROLLER GUIDE BRACKET		1
33	77-290-04	WELDMENT, BASKET SIDE		1
34	77-290-05	WELDMENT, LATCH BRACKET		1
35	77-290-06	WAND HOLDER WELDMENT		1
36	77-290-07	PRESSURE WASHER WAND HOLDER WELDMENT		1
37	77-290-08	WELDMENT, DOOR SKID		2
38	77-290-09	WELDMENT, BASKET DOOR		1
39	77-290-11	WELDMENT, SUPPORT BRACKET		1
40	77-290-12	PIPE SUPPORT BRACKET		2
41	77-290-13	PIPE SUPPORT		2
42	77-290-15	BASKET, BACK PANEL		1
43	77-290-16	COVER PLATE		2
44	77-290-17	COVER PLATE		1

E.H. WACHS
 605 Highland Parkway
 Waco, TX 76798
 WWW.EH-WACHS.COM

STANDARD BUILDER (DIBEE-AWMS) (BH)

REV: 6/1/2019
 DATE: 9/1/2019
 SHEET: 3 OF 17
 PROJECT: MWV
 DRAWING NO: 77-000-60

WACHS
 605 Highland Parkway
 Waco, TX 76798
 WWW.EH-WACHS.COM

REV: 6/1/2019
 DATE: 9/1/2019
 SHEET: 3 OF 17
 PROJECT: MWV
 DRAWING NO: 77-000-60

- NOTES:**
1. VIEWS SHOW OPTIONAL EQUIPMENT:
 - ERV-250 WITH BLUETOOTH KIT: P/N 77-404-00
 - 250 GAL SPOILS TANK: P/N 77-431-02-00
 - 350 GAL SPOILS TANK: P/N 77-432-02-00
 - SERVICE LIGHT PACKAGE: P/N 77-460-00
 - HYDRAULIC HOSE REEL KIT: P/N 77-413-05
 - HC-100 VITALS CONTROLLER KIT: P/N 77-422-01

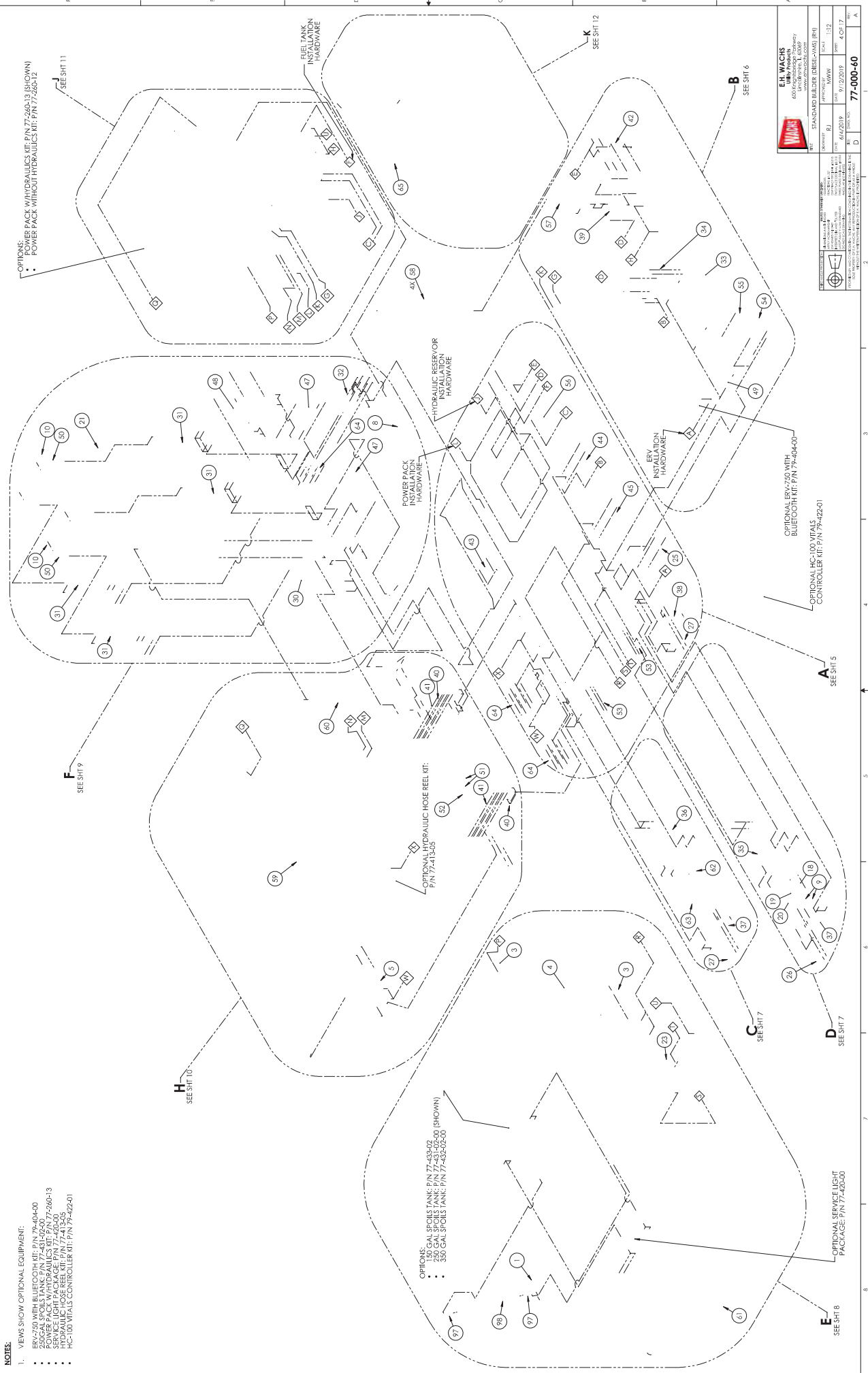

E.H. WACHS
 6050 Highland Drive
 Wachs Hydraulic Power
 www.wachshydraulic.com

REV	DATE	BY	CHKD	APP'D
1	06/20/19	MMW	MMW	MMW
2	07/02/19	MMW	MMW	MMW
3	07/02/19	MMW	MMW	MMW
4	07/02/19	MMW	MMW	MMW
5	07/02/19	MMW	MMW	MMW
6	07/02/19	MMW	MMW	MMW
7	07/02/19	MMW	MMW	MMW
8	07/02/19	MMW	MMW	MMW
9	07/02/19	MMW	MMW	MMW
10	07/02/19	MMW	MMW	MMW
11	07/02/19	MMW	MMW	MMW
12	07/02/19	MMW	MMW	MMW
13	07/02/19	MMW	MMW	MMW
14	07/02/19	MMW	MMW	MMW
15	07/02/19	MMW	MMW	MMW
16	07/02/19	MMW	MMW	MMW
17	07/02/19	MMW	MMW	MMW
18	07/02/19	MMW	MMW	MMW
19	07/02/19	MMW	MMW	MMW
20	07/02/19	MMW	MMW	MMW
21	07/02/19	MMW	MMW	MMW
22	07/02/19	MMW	MMW	MMW
23	07/02/19	MMW	MMW	MMW
24	07/02/19	MMW	MMW	MMW
25	07/02/19	MMW	MMW	MMW
26	07/02/19	MMW	MMW	MMW
27	07/02/19	MMW	MMW	MMW
28	07/02/19	MMW	MMW	MMW
29	07/02/19	MMW	MMW	MMW
30	07/02/19	MMW	MMW	MMW
31	07/02/19	MMW	MMW	MMW
32	07/02/19	MMW	MMW	MMW
33	07/02/19	MMW	MMW	MMW
34	07/02/19	MMW	MMW	MMW
35	07/02/19	MMW	MMW	MMW
36	07/02/19	MMW	MMW	MMW
37	07/02/19	MMW	MMW	MMW
38	07/02/19	MMW	MMW	MMW
39	07/02/19	MMW	MMW	MMW
40	07/02/19	MMW	MMW	MMW
41	07/02/19	MMW	MMW	MMW
42	07/02/19	MMW	MMW	MMW
43	07/02/19	MMW	MMW	MMW
44	07/02/19	MMW	MMW	MMW
45	07/02/19	MMW	MMW	MMW
46	07/02/19	MMW	MMW	MMW
47	07/02/19	MMW	MMW	MMW
48	07/02/19	MMW	MMW	MMW
49	07/02/19	MMW	MMW	MMW
50	07/02/19	MMW	MMW	MMW
51	07/02/19	MMW	MMW	MMW
52	07/02/19	MMW	MMW	MMW
53	07/02/19	MMW	MMW	MMW
54	07/02/19	MMW	MMW	MMW
55	07/02/19	MMW	MMW	MMW
56	07/02/19	MMW	MMW	MMW
57	07/02/19	MMW	MMW	MMW
58	07/02/19	MMW	MMW	MMW
59	07/02/19	MMW	MMW	MMW
60	07/02/19	MMW	MMW	MMW
61	07/02/19	MMW	MMW	MMW
62	07/02/19	MMW	MMW	MMW
63	07/02/19	MMW	MMW	MMW
64	07/02/19	MMW	MMW	MMW
65	07/02/19	MMW	MMW	MMW
66	07/02/19	MMW	MMW	MMW
67	07/02/19	MMW	MMW	MMW
68	07/02/19	MMW	MMW	MMW
69	07/02/19	MMW	MMW	MMW
70	07/02/19	MMW	MMW	MMW
71	07/02/19	MMW	MMW	MMW
72	07/02/19	MMW	MMW	MMW
73	07/02/19	MMW	MMW	MMW
74	07/02/19	MMW	MMW	MMW
75	07/02/19	MMW	MMW	MMW
76	07/02/19	MMW	MMW	MMW
77	07/02/19	MMW	MMW	MMW
78	07/02/19	MMW	MMW	MMW
79	07/02/19	MMW	MMW	MMW
80	07/02/19	MMW	MMW	MMW
81	07/02/19	MMW	MMW	MMW
82	07/02/19	MMW	MMW	MMW
83	07/02/19	MMW	MMW	MMW
84	07/02/19	MMW	MMW	MMW
85	07/02/19	MMW	MMW	MMW
86	07/02/19	MMW	MMW	MMW
87	07/02/19	MMW	MMW	MMW
88	07/02/19	MMW	MMW	MMW
89	07/02/19	MMW	MMW	MMW
90	07/02/19	MMW	MMW	MMW
91	07/02/19	MMW	MMW	MMW
92	07/02/19	MMW	MMW	MMW
93	07/02/19	MMW	MMW	MMW
94	07/02/19	MMW	MMW	MMW
95	07/02/19	MMW	MMW	MMW
96	07/02/19	MMW	MMW	MMW
97	07/02/19	MMW	MMW	MMW
98	07/02/19	MMW	MMW	MMW
99	07/02/19	MMW	MMW	MMW
100	07/02/19	MMW	MMW	MMW

PROJECT NO.	77-000-40
DATE	07/02/19
BY	MMW
CHKD	MMW
APP'D	MMW
TITLE	STANDARD BUILDER (BEEB-000) (BH)
SCALE	1:12
SHEET	4 OF 17

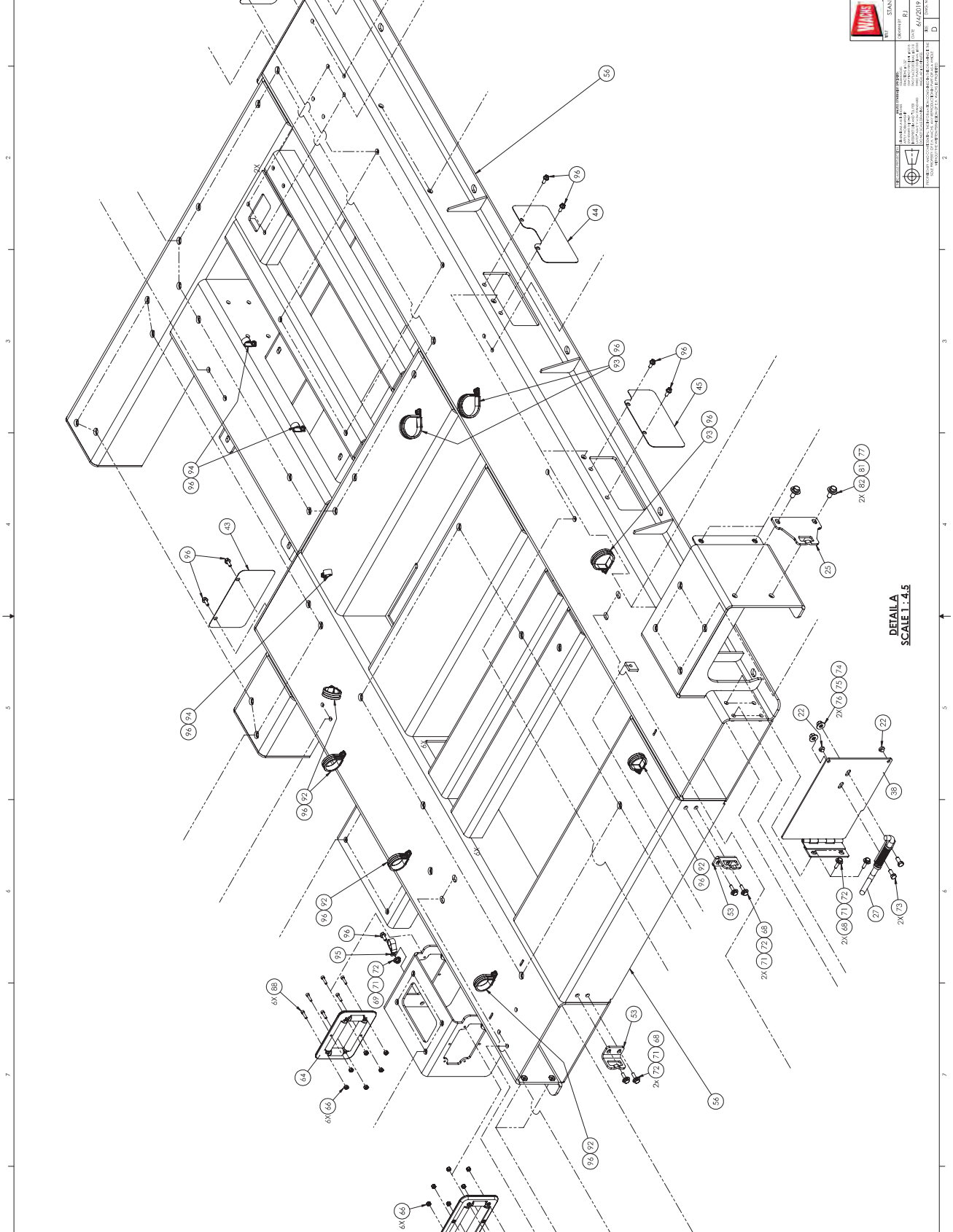

DETAIL A
SCALE 1:4.5

		E.H. WACHS 6053 Ringelstraße, 70839 Stuttgart www.wachs.de	
REF: STANDARD BÜLDER (BEELE-WMS) (BH)	DESIGNED BY: R.J.	PROJECT: MWN	SCALE: 1:3
DATE: 01/20/2019	DATE: 01/20/2019	DATE: 01/20/2019	DATE: 01/20/2019
NO.: 77-000-60	NO.: 77-000-60	NO.: 77-000-60	NO.: 77-000-60

- NOTES:**
- VIEW SHOWS OPTIONAL EQUIPMENT:
 - ERV-750 WITH BLUETOOTH KIT: P/N 79-40-00

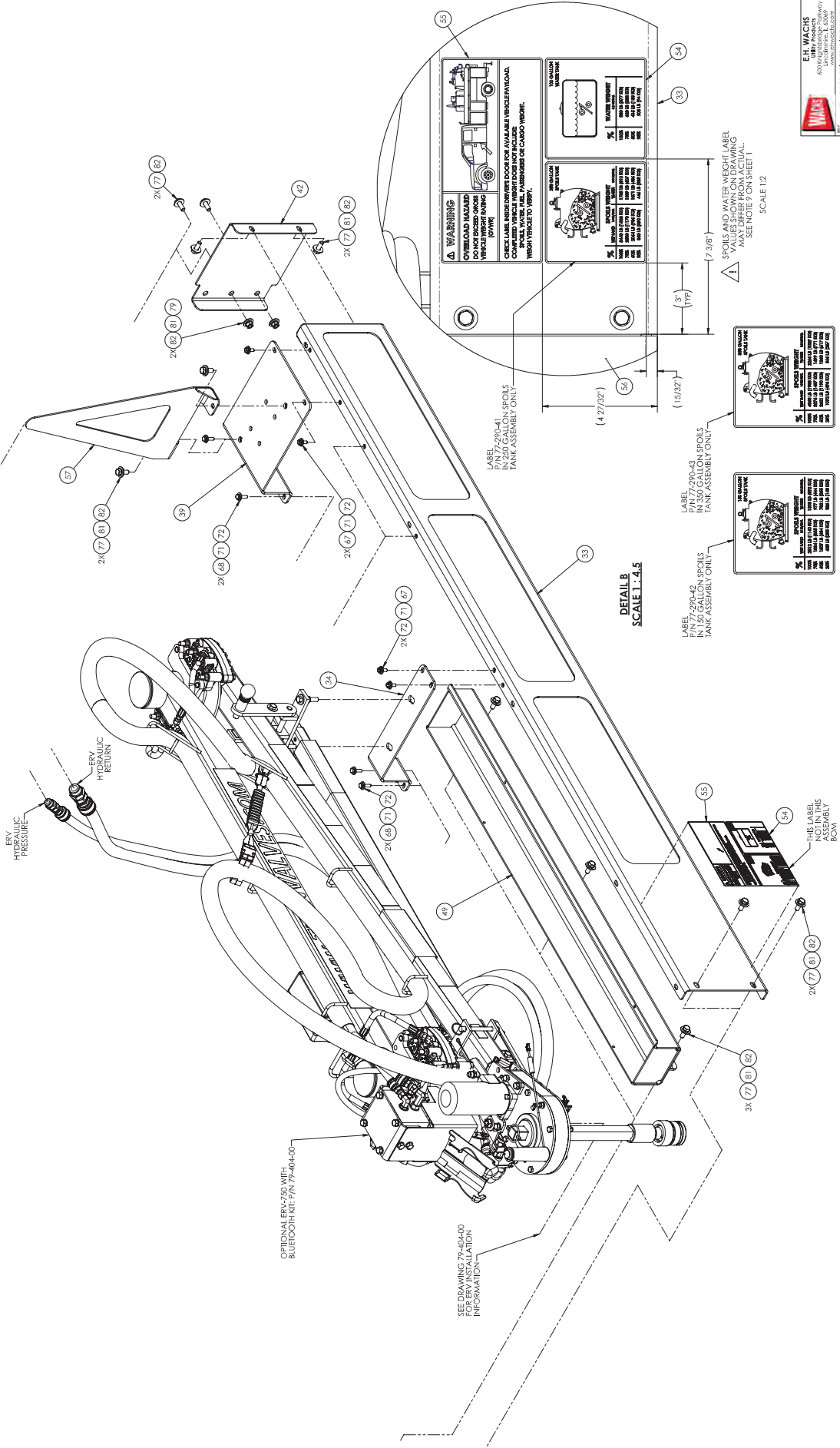

E.H. WACHS
605 Technology Parkway
Mankato, MN 56001
WWW.EH-WACHS.COM

REV: STANDARD BUILDER (BEE-LVMS) (RH)

DATE: 8/20/2019	SCALE: 1:8
BY: MVM	APP: 605-17
77-000-60	

1:8

DATE: 8/20/2019

SCALE: 1:8

APP: 605-17

BY: MVM

77-000-60

1:8

DATE: 8/20/2019

SCALE: 1:8

APP: 605-17

BY: MVM

77-000-60

1:8

DATE: 8/20/2019

SCALE: 1:8

APP: 605-17

BY: MVM

77-000-60

1:8

DATE: 8/20/2019

SCALE: 1:8

APP: 605-17

BY: MVM

77-000-60

1:8

DATE: 8/20/2019

SCALE: 1:8

APP: 605-17

BY: MVM

77-000-60

1:8

DATE: 8/20/2019

SCALE: 1:8

APP: 605-17

BY: MVM

77-000-60

1:8

DATE: 8/20/2019

SCALE: 1:8

APP: 605-17

BY: MVM

77-000-60

1:8

DATE: 8/20/2019

SCALE: 1:8

APP: 605-17

BY: MVM

77-000-60

1:8

DATE: 8/20/2019

SCALE: 1:8

APP: 605-17

BY: MVM

77-000-60

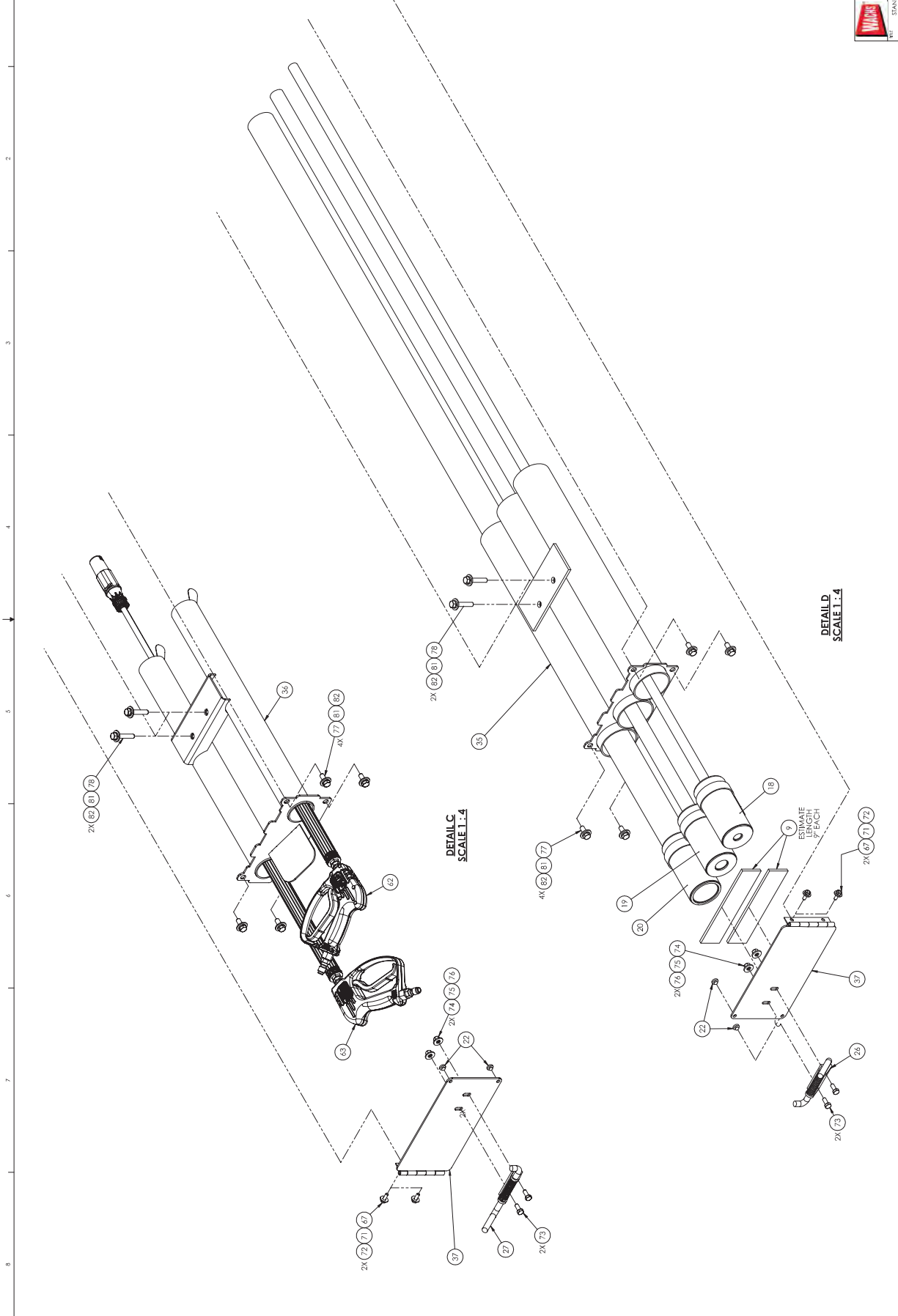

E.H. WACHS 600 Northridge Parkway Northridge, CA 91329 WWW.EHWACHS.COM	
REV: STANDARD BUILDER (BEE-LVMS) (RH)	Scale: 1:12
Drawn by: RJ	Approved: MWN
Date: 6/10/2019	Date: 9/10/2019
Sheet: POF-17	Sheet: POF-17
Project: 77-000-60	Project: 77-000-60

1 2 3 4 5 6 7 8

A B C D E F

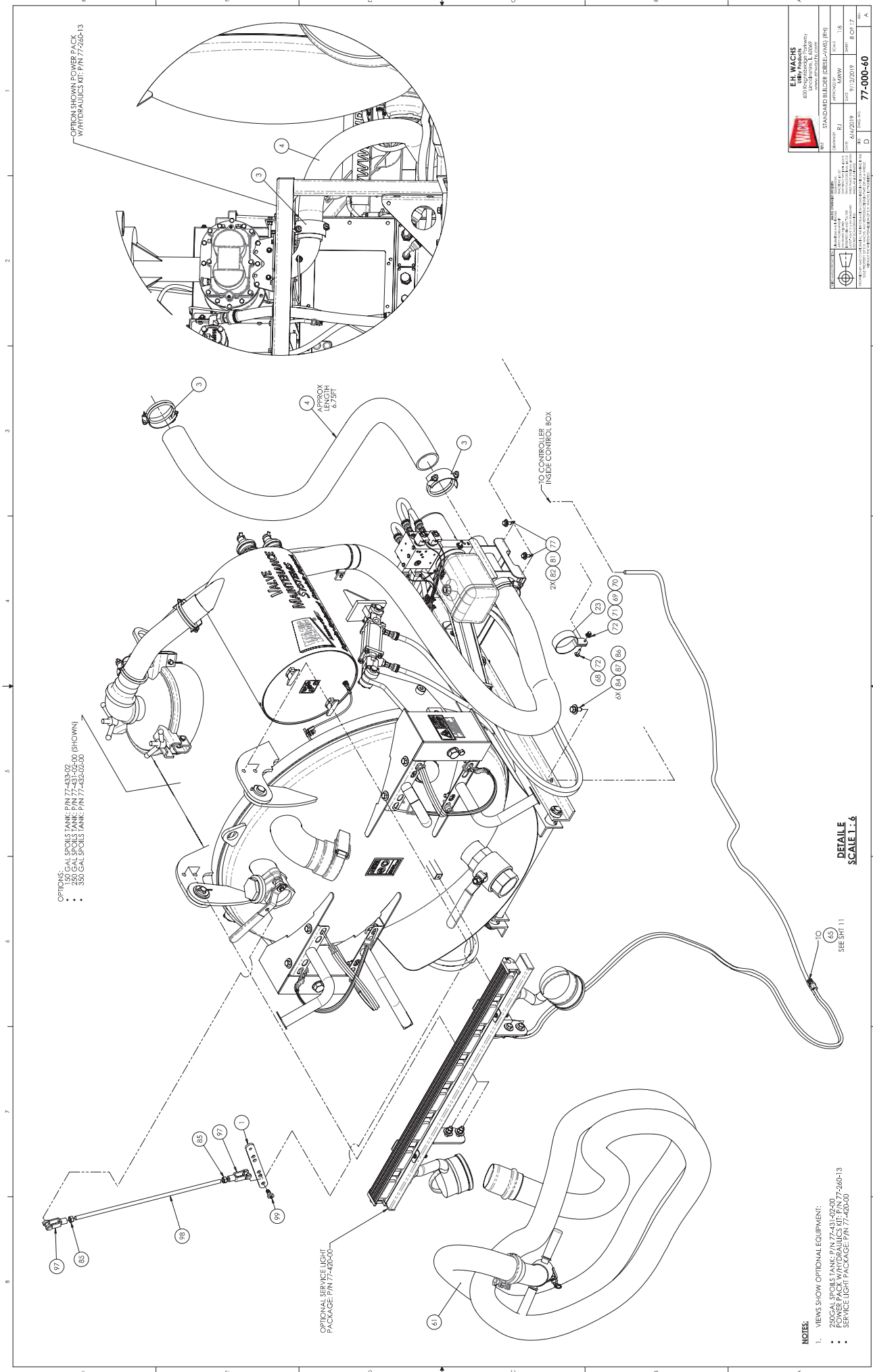

OPTIONS:
 • 150 GAL. SPILLS TANK: P/N 77-432-02 (SHOWN)
 • 350 GAL. SPILLS TANK: P/N 77-432-02-30

OPTION SHOWN POWER PACK
 W/ HYDRAULICS KIT: P/N 77-260-13

OPTIONAL SERVICE LIGHT
 PACKAGE: P/N 77-420-00

TO CONTROLS
 INSIDE CONTROL BOX

NOTES:
 1. VIEWS SHOW OPTIONAL EQUIPMENT:
 • 200 GAL. SPILLS TANK: P/N 77-431-02-00
 • POWER PACK W/ HYDRAULICS KIT: P/N 77-260-13
 • SERVICE LIGHT PACKAGE: P/N 77-420-00

DETAIL
 SCALE 1:6

65
 SEE SH 11

WACHS	
E.H. WACHS 600 Northridge Parkway Northridge, CA 91329 WWW.WACHS.COM	
REV: STANDARD BUILDER (DIBEL-VMS) (RH)	SCALE: 1:6
DRAWN BY: MVM	SHEET: RCF-17
DATE: 9/10/2019	
NO. 77-000-60	

NOTES:

- 1. VIEWS SHOW OPTIONAL EQUIPMENT.
- POWER PACK W/HYDRAULICS KIT P/N 77-260-13

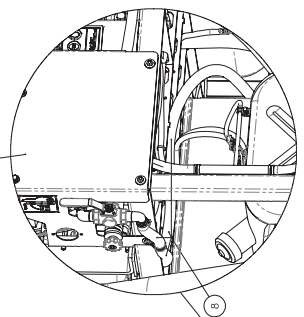
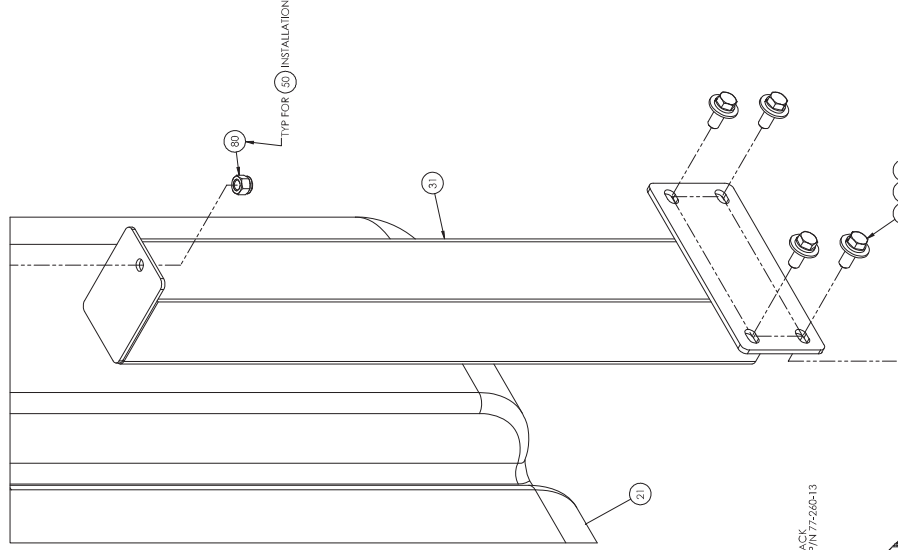
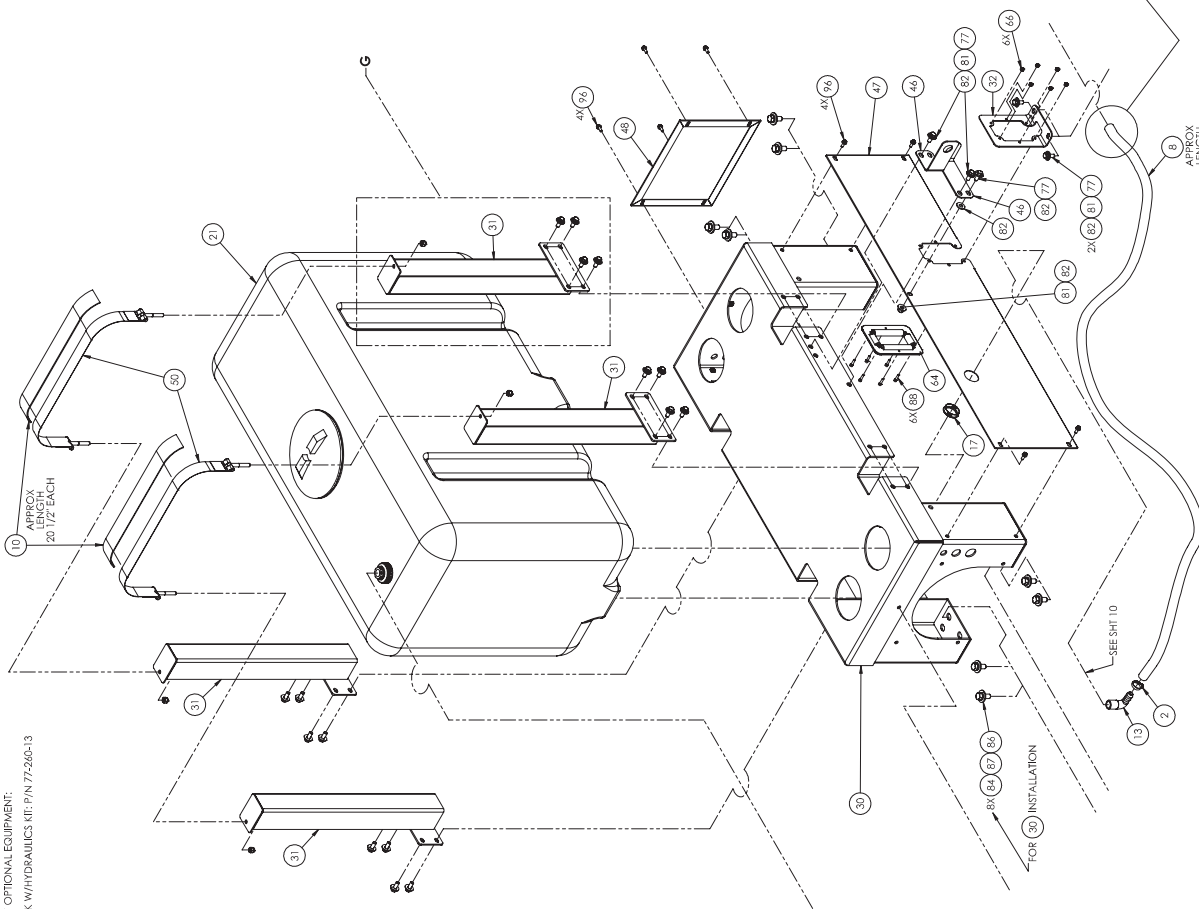

DETAIL
SCALE 1:2

SCALE 1:6

DETAIL

WACHS		E.H. WACHS	
STANDARD BUILDER (DIESEL-MS) (RH)		600 N. Highway 100, P.O. Box 100	
WWW.WACHS.COM		WWW.WACHS.COM	
DESIGNED BY	REVISED BY	DATE	SCALE
BJ	MW	9/1/2019	1:2
DATE	DATE	DATE	DATE
6/2/2019	6/2/2019	6/2/2019	6/2/2019
REV	DESCRIPTION	REV	DESCRIPTION
1	77-000-60	1	77-000-60

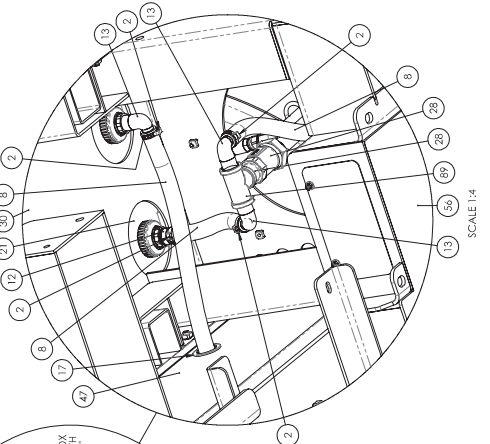
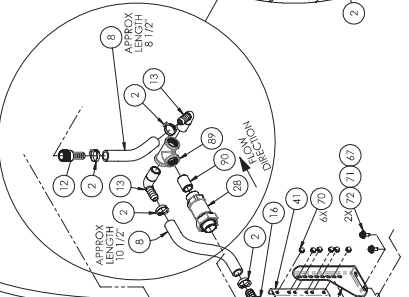
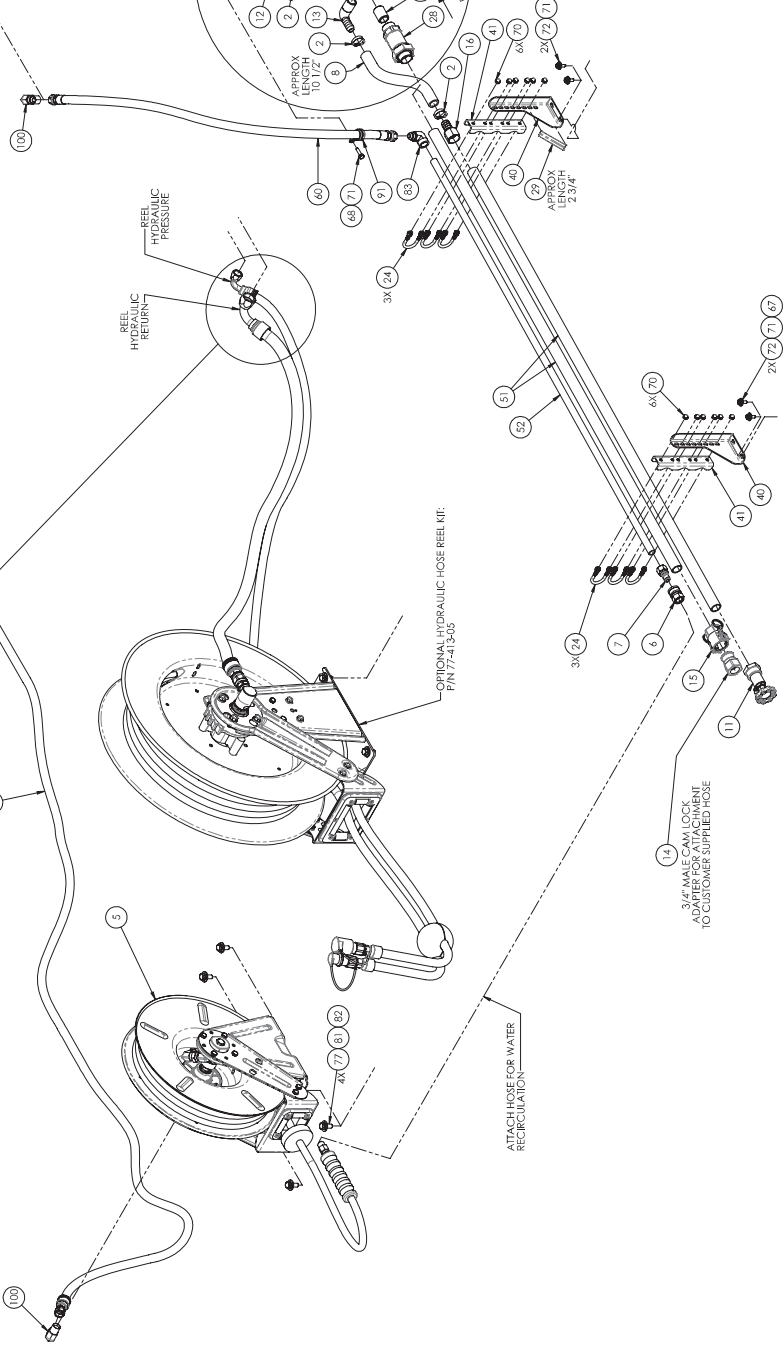
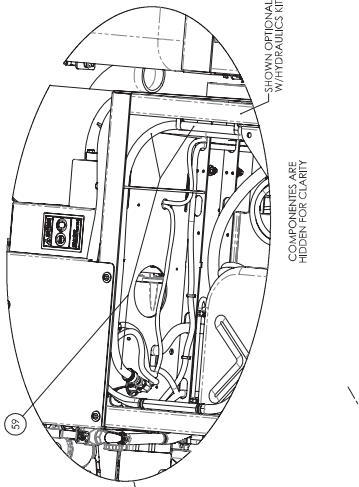
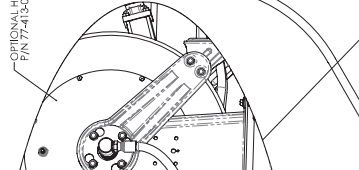
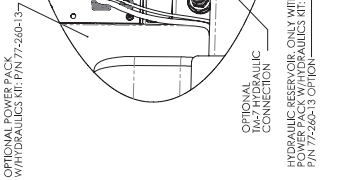

SCALE 1:4

NOTES:
 1. VIEWS SHOW OPTIONAL EQUIPMENT:
 • POWER PACK W/HYDRAULICS KIT: P/N 77-269-13
 • HYDRAULIC HOSE REEL KIT: P/N 77-413-05

DETAIL I

WACHS		E.H. WACHS 605 Engineering Parkway Waukegan, IL 60087 WWW.WACHS.COM	
REV	STANDARD BUILDER (BEEB-0045) (RH)	DATE	1-8
DESIGNED BY	RJ	APPROVED BY	MW
DATE	6/10/2019	DATE	6/10/2019
BY	6/10/2019	DATE	6/10/2019
NO.	77-000-60	REV.	A

NOTES:

1. VIEWS SHOW OPTIONAL EQUIPMENT:
 • POWER PACK WITH HYDRAULICS KIT, P/N 77-260-13

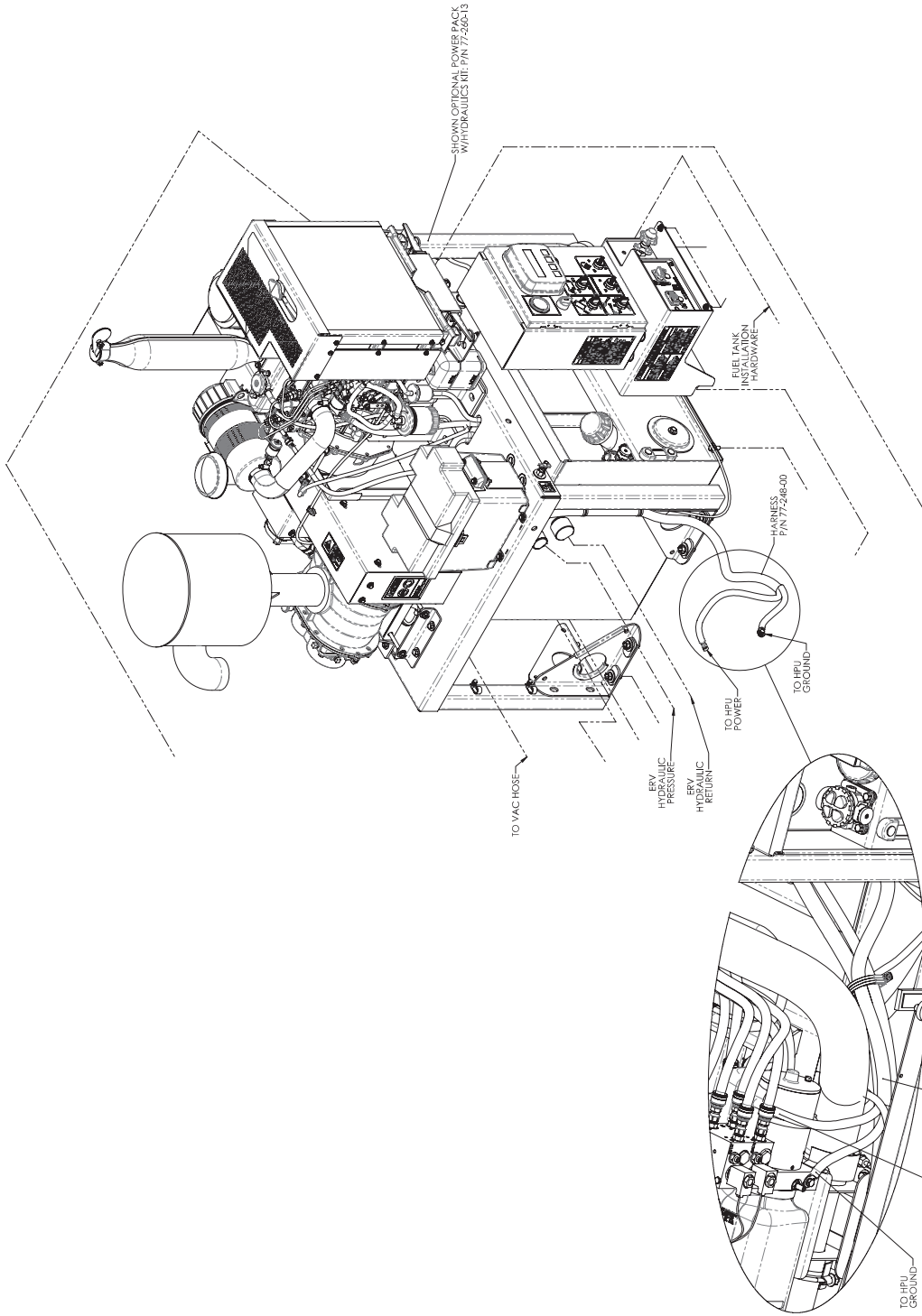

DETAIL J

WACHS		E.H. WACHS	
STANDARD BUILDER (DEE-L-MS) (RH)		600 Northridge Parkway Wachs Building Wachs, TX 75781-1000 WWW.WACHS.COM	
REV	DATE	BY	CHKD
1	08/20/19	WVW	MSK
2	09/20/19	WVW	MSK
3	11/01/17	WVW	MSK
PART NUMBER: 77-000-60			REV: A

NOTES:

1. VIEWS SHOW OPTIONAL EQUIPMENT:
 • POWER PACK W/HYDRAULICS KIT: P/N 77-260-13

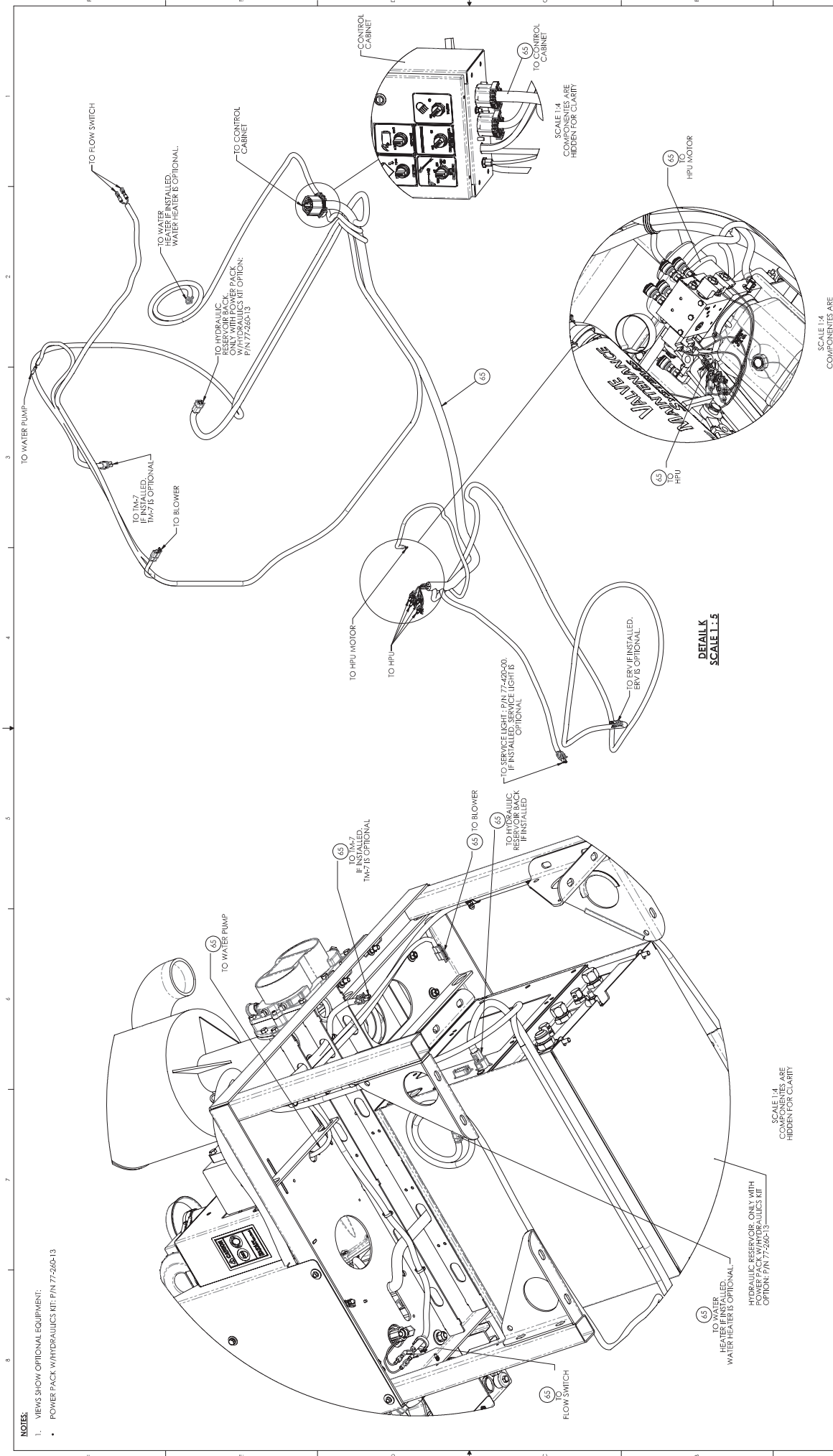

SCALE 1:4
 COMPONENTS ARE HIDDEN FOR CLARITY

SCALE 1:5
 COMPONENTS ARE HIDDEN FOR CLARITY

SCALE 1:4
 COMPONENTS ARE HIDDEN FOR CLARITY

SCALE 1:4
 COMPONENTS ARE HIDDEN FOR CLARITY

SCALE 1:4
 COMPONENTS ARE HIDDEN FOR CLARITY

E.H. WACHS	
605 Highland Parkway Waukegan, IL 60087 www.ehwachs.com	
REV	STANDARD BUILDER (DBEEL-0045) (RH)
DATE	11/15/19
BY	MMW
APP'D	MMW
DATE	9/10/2019
SCALE	1:5
FIG.	12 OF 17
REV	77-000-60

WACHS	
605 Highland Parkway Waukegan, IL 60087 www.ehwachs.com	
REV	STANDARD BUILDER (DBEEL-0045) (RH)
DATE	11/15/19
BY	MMW
APP'D	MMW
DATE	9/10/2019
SCALE	1:5
FIG.	12 OF 17
REV	77-000-60

WACHS	
605 Highland Parkway Waukegan, IL 60087 www.ehwachs.com	
REV	STANDARD BUILDER (DBEEL-0045) (RH)
DATE	11/15/19
BY	MMW
APP'D	MMW
DATE	9/10/2019
SCALE	1:5
FIG.	12 OF 17
REV	77-000-60

WACHS	
605 Highland Parkway Waukegan, IL 60087 www.ehwachs.com	
REV	STANDARD BUILDER (DBEEL-0045) (RH)
DATE	11/15/19
BY	MMW
APP'D	MMW
DATE	9/10/2019
SCALE	1:5
FIG.	12 OF 17
REV	77-000-60

WACHS	
605 Highland Parkway Waukegan, IL 60087 www.ehwachs.com	
REV	STANDARD BUILDER (DBEEL-0045) (RH)
DATE	11/15/19
BY	MMW
APP'D	MMW
DATE	9/10/2019
SCALE	1:5
FIG.	12 OF 17
REV	77-000-60

WACHS	
605 Highland Parkway Waukegan, IL 60087 www.ehwachs.com	
REV	STANDARD BUILDER (DBEEL-0045) (RH)
DATE	11/15/19
BY	MMW
APP'D	MMW
DATE	9/10/2019
SCALE	1:5
FIG.	12 OF 17
REV	77-000-60

WACHS	
605 Highland Parkway Waukegan, IL 60087 www.ehwachs.com	
REV	STANDARD BUILDER (DBEEL-0045) (RH)
DATE	11/15/19
BY	MMW
APP'D	MMW
DATE	9/10/2019
SCALE	1:5
FIG.	12 OF 17
REV	77-000-60

WACHS	
605 Highland Parkway Waukegan, IL 60087 www.ehwachs.com	
REV	STANDARD BUILDER (DBEEL-0045) (RH)
DATE	11/15/19
BY	MMW
APP'D	MMW
DATE	9/10/2019
SCALE	1:5
FIG.	12 OF 17
REV	77-000-60

WACHS	
605 Highland Parkway Waukegan, IL 60087 www.ehwachs.com	
REV	STANDARD BUILDER (DBEEL-0045) (RH)
DATE	11/15/19
BY	MMW
APP'D	MMW
DATE	9/10/2019
SCALE	1:5
FIG.	12 OF 17
REV	77-000-60

WACHS	
605 Highland Parkway Waukegan, IL 60087 www.ehwachs.com	
REV	STANDARD BUILDER (DBEEL-0045) (RH)
DATE	11/15/19
BY	MMW
APP'D	MMW
DATE	9/10/2019
SCALE	1:5
FIG.	12 OF 17
REV	77-000-60

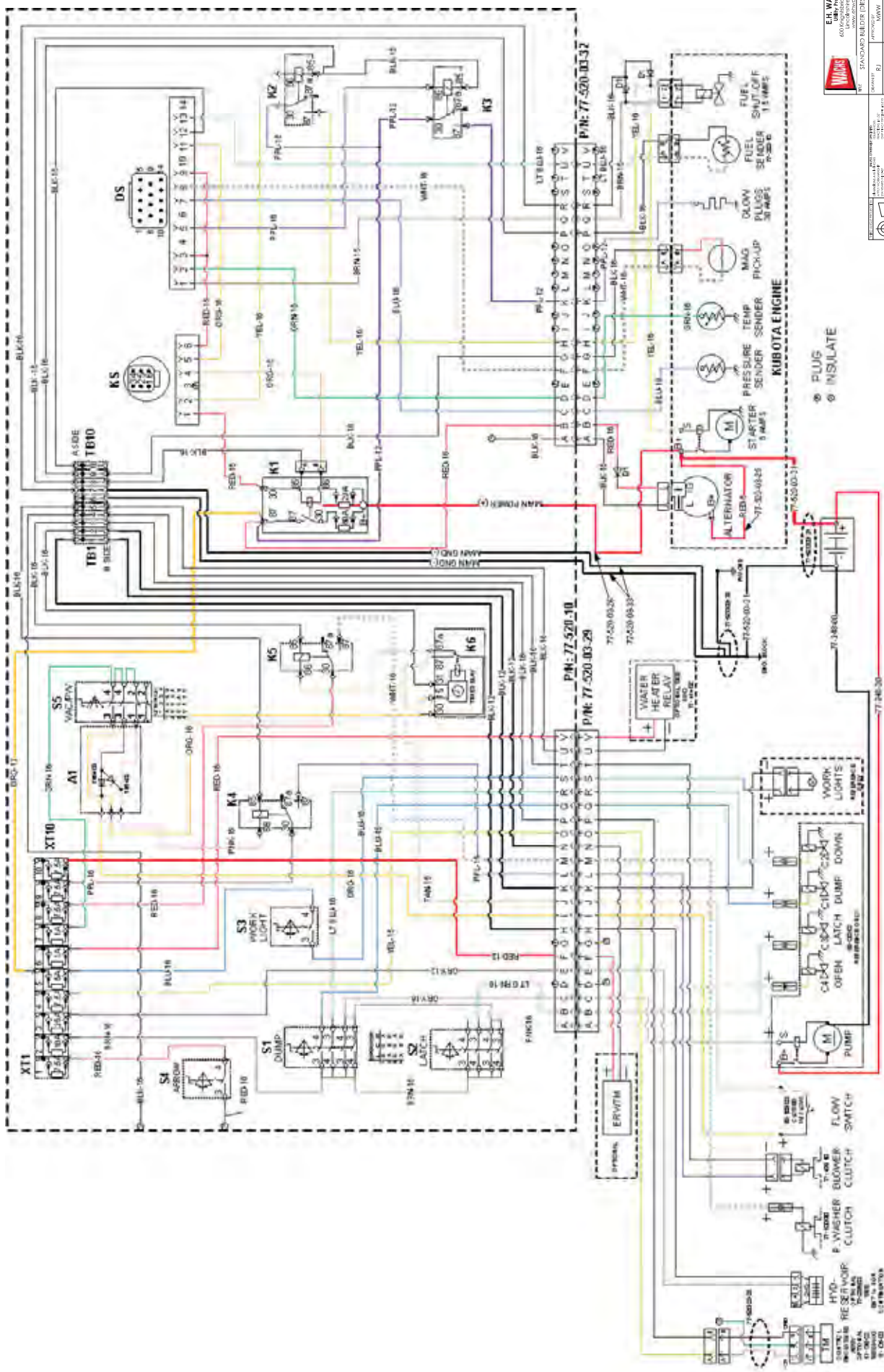

SEE SHIT 14 FOR CONTINUATION

WAGERS		E.H. WAGERS	
STANDARD BUILDER (DEER-4045) (B)		605 Kingsbridge Parkway	
www.wagers.com		www.wagers.com	
REV	DATE	BY	CHKD
1	01/02/09	BJ	LS
2	06/20/09	MW	LS
3	03/01/17		
4			
5			
6			
7			
8			
9			
10			
11			
12			
13			
14			
15			
16			
17			
18			
19			
20			
21			
22			
23			
24			
25			
26			
27			
28			
29			
30			
31			
32			
33			
34			
35			
36			
37			
38			
39			
40			
41			
42			
43			
44			
45			
46			
47			
48			
49			
50			
51			
52			
53			
54			
55			
56			
57			
58			
59			
60			
61			
62			
63			
64			
65			
66			
67			
68			
69			
70			
71			
72			
73			
74			
75			
76			
77			
78			
79			
80			
81			
82			
83			
84			
85			
86			
87			
88			
89			
90			
91			
92			
93			
94			
95			
96			
97			
98			
99			
100			

77-000-60

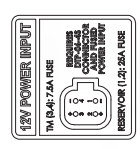

HARNESSES 77-520-03-29 SEE SHEET 13 FOR CONTINUATION

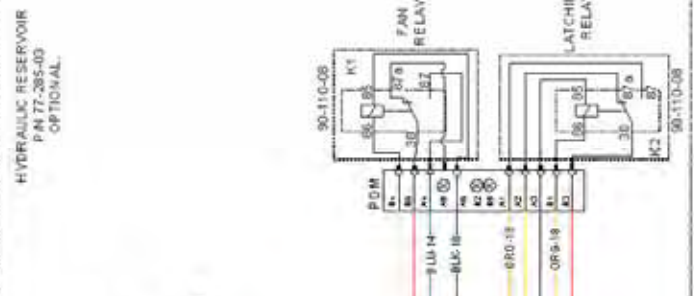

PLUG INSULATE

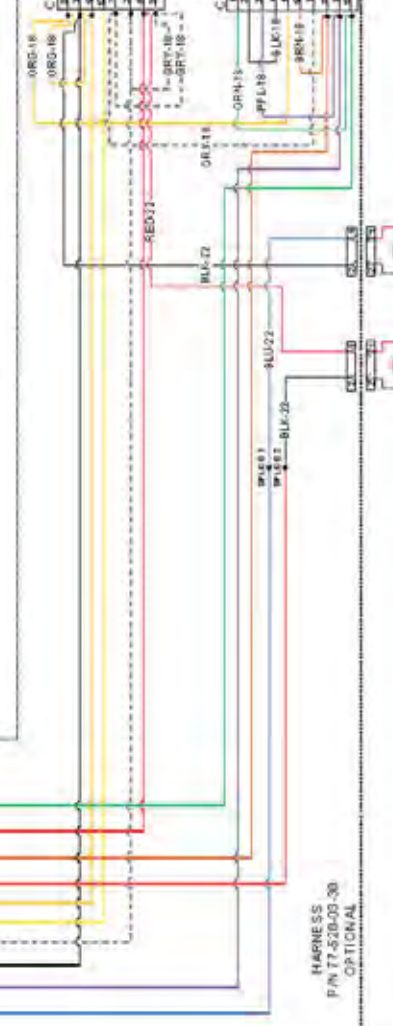
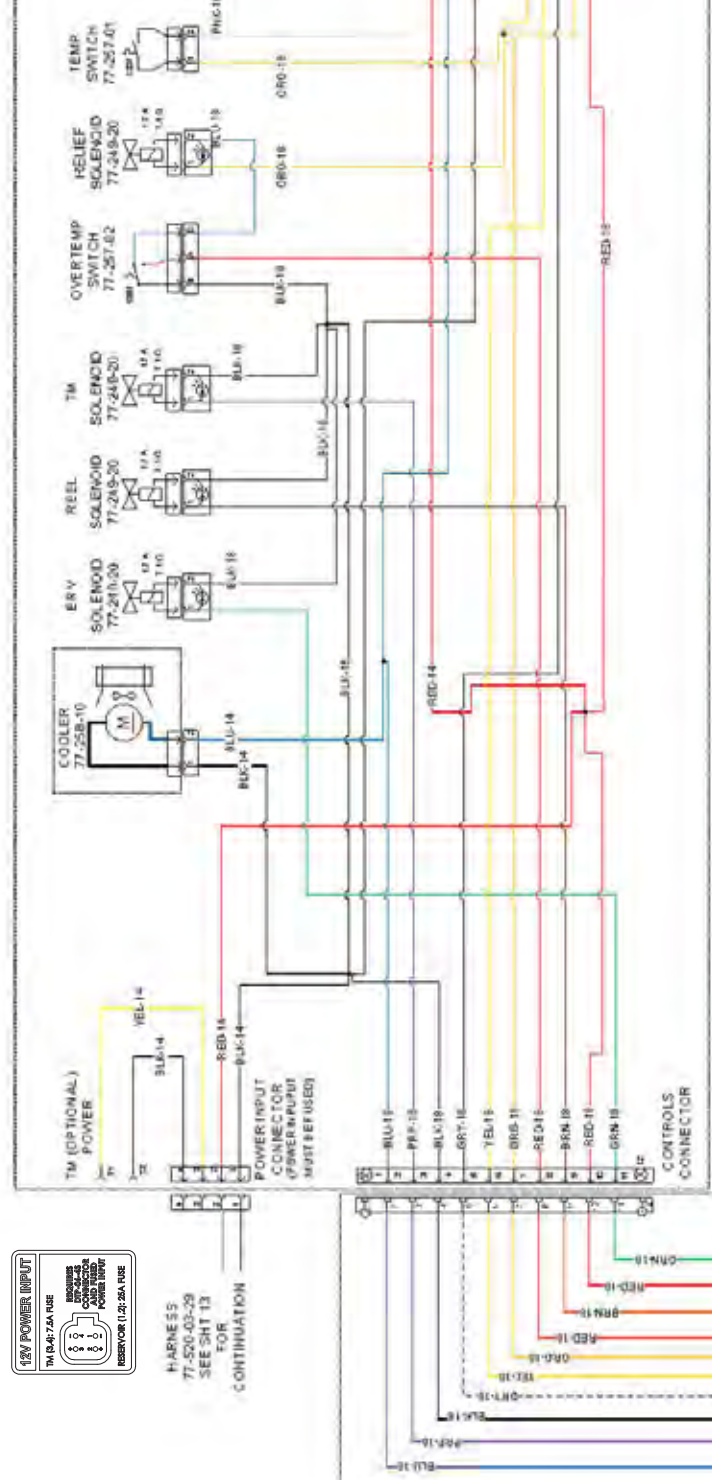
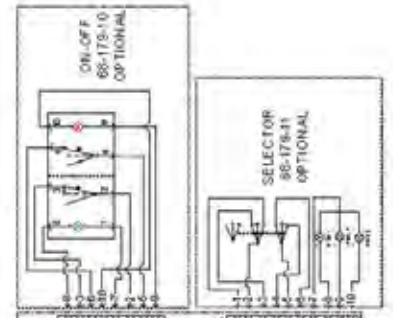

	E.H. WACKS 605 Northridge Parkway Northridge, CA 91321 WWW.WACKS.COM	REV: STANDARD BUILDER (RESERVOIR) (R) DATE: 01/02/09 BY: HJG	SHEET: 15 OF: 17 OF: 17	
	APPROVED FOR: [Signature] TITLE: [Title] DATE: 06/20/09 BY: [Name]	PART NUMBER: 77-000-60 DESCRIPTION: HYDRAULIC RESERVOIR (RESERVOIR) (R) REV: 02/09	SHEET: 15 OF: 17 OF: 17	REV: 02/09 PART NUMBER: 77-000-60 DESCRIPTION: HYDRAULIC RESERVOIR (RESERVOIR) (R) REV: 02/09
	APPROVED FOR: [Signature] TITLE: [Title] DATE: 06/20/09 BY: [Name]	PART NUMBER: 77-000-60 DESCRIPTION: HYDRAULIC RESERVOIR (RESERVOIR) (R) REV: 02/09	SHEET: 15 OF: 17 OF: 17	REV: 02/09 PART NUMBER: 77-000-60 DESCRIPTION: HYDRAULIC RESERVOIR (RESERVOIR) (R) REV: 02/09
	APPROVED FOR: [Signature] TITLE: [Title] DATE: 06/20/09 BY: [Name]	PART NUMBER: 77-000-60 DESCRIPTION: HYDRAULIC RESERVOIR (RESERVOIR) (R) REV: 02/09	SHEET: 15 OF: 17 OF: 17	REV: 02/09 PART NUMBER: 77-000-60 DESCRIPTION: HYDRAULIC RESERVOIR (RESERVOIR) (R) REV: 02/09
	APPROVED FOR: [Signature] TITLE: [Title] DATE: 06/20/09 BY: [Name]	PART NUMBER: 77-000-60 DESCRIPTION: HYDRAULIC RESERVOIR (RESERVOIR) (R) REV: 02/09	SHEET: 15 OF: 17 OF: 17	REV: 02/09 PART NUMBER: 77-000-60 DESCRIPTION: HYDRAULIC RESERVOIR (RESERVOIR) (R) REV: 02/09

OVERHEAT INDICATOR 77-272-20
 OPTIONAL
 FAN INDICATOR 77-272-10
 OPTIONAL
 SEE SHEET 13 FOR CONTINUATION

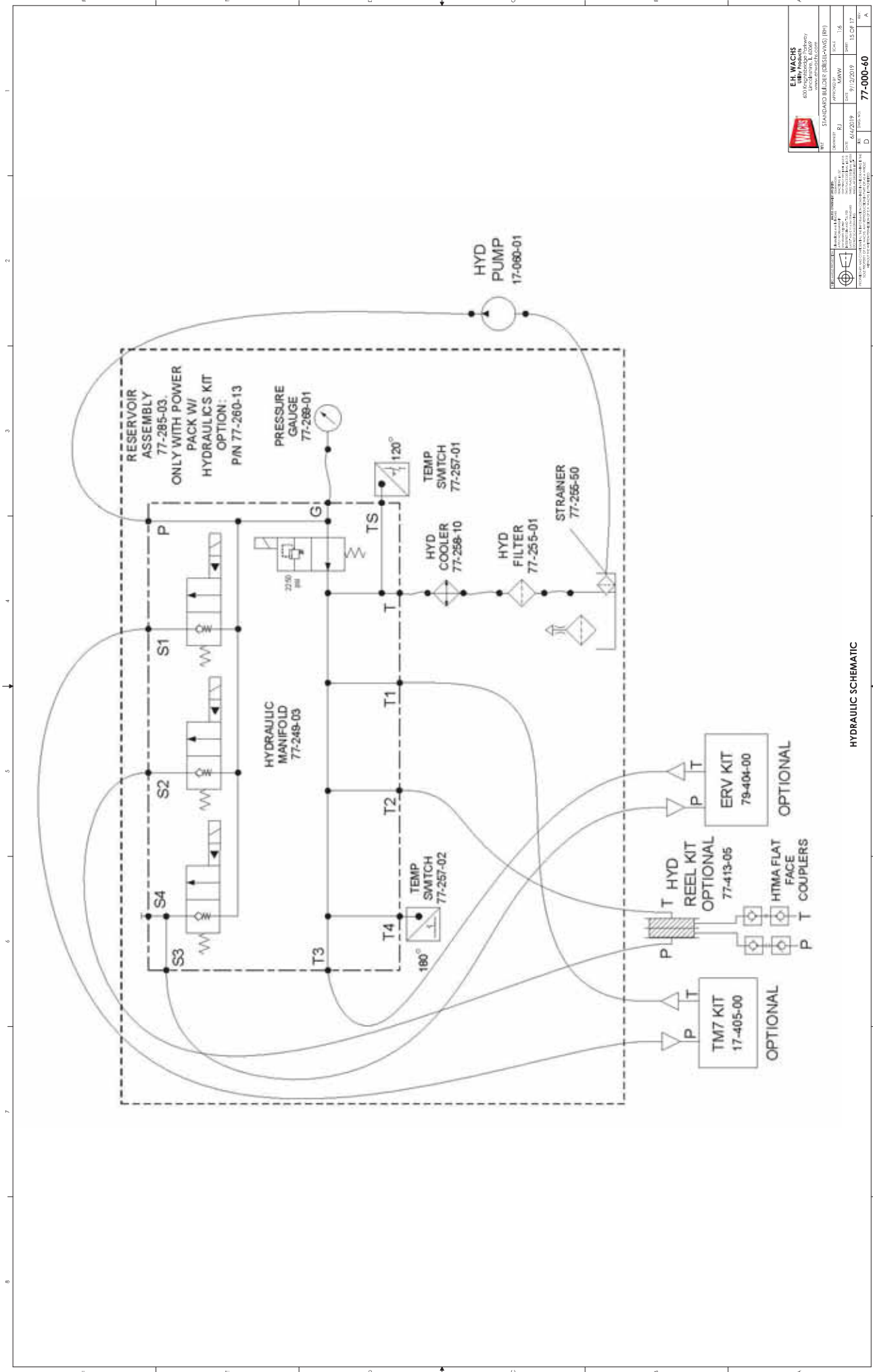

HYDRAULIC SCHEMATIC

		E.H. WACHS 605 Northridge Parkway Northridge, CA 91329 WWW.WACHS.COM	
REV:	STANDARD BUILDER (RESUBMS) (B)	DATE:	1-8
DESIGNED BY:	B.J.	APPROVED BY:	M.W.
DATE:	6/20/19	DATE:	10/01/17
BY:	WACHS	DATE:	77-000-60
NO.:		REV.:	A

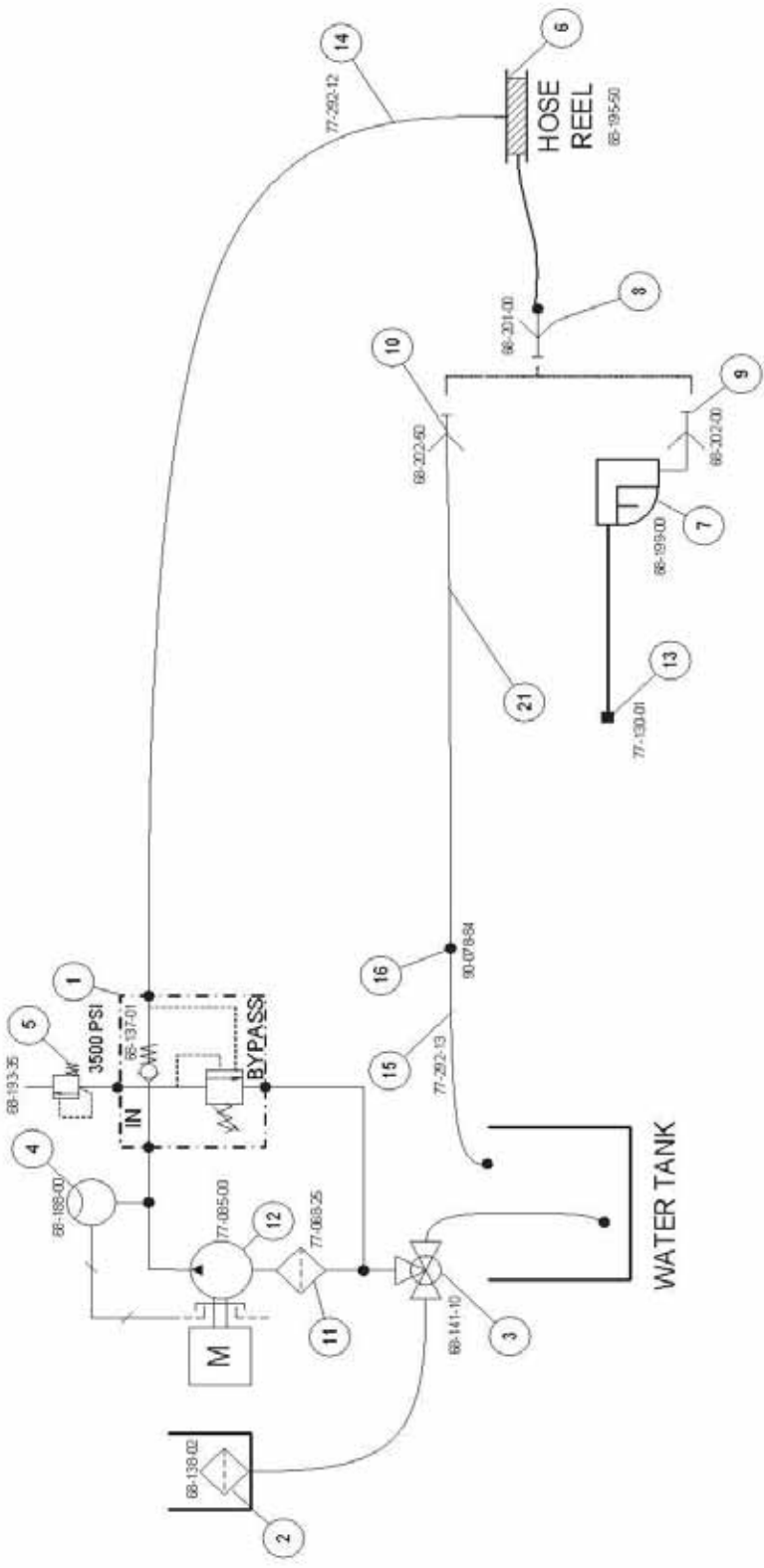

PARTS LIST FOR PRESSURE WASHER SYSTEM SCHEMATICS. REFERENCE ONLY. BALLOONS DO NOT CORRESPOND WITH BOM TABLE ON SHEET 2.

SCHEMATIC ITEM	PART NUMBER	DESCRIPTION
1	68-150-1	VALVE TRAPPED PRESSURE UNLOADER
2	68-138-02	STRAINER
3	68-141-10	BALL VALVE, 3-WAY
4	68-188-00	FLOW SWITCH
5	68-195-35	SAFETY RELIEF, 3500 PSI
6	68-195-50	HOSE REEL
7	68-199-00	SPRAY GUN
8	68-201-00	GD COUPLER, 3/8" X 3/8" NPT-F
9	68-202-00	GD PLUG, 3/8" X 3/8" NPT-F
10	68-202-50	GD PLUG, 3/8" X 3/8" NPT-F
11	77-068-25	STRAINER
12	77-085-00	PUMP PRESSURE WASHER, 2.6 GPM, 3000 PSI
13	77-130-01	NOZZLE, 000 X 1.5 DEGREE
14	77-292-12	1.51 5/16" HOSE ASSEMBLY, .08 F.I.X-.08 F.I.X-.08 HOSE
15	77-292-13	4.3 1/2" HOSE ASSEMBLY, .08 F.I.X-.08 F.I.X-.08 HOSE
16	90-078-84	ADAPTER, 8.134" - 1.6M X 3/8" NPT-F 90

PRESSURE WASHER SYSTEM SCHEMATIC

E.H. WACHS
 605 Northridge Parkway
 Northridge, CA 91329
 WWW.EHWACHS.COM

REV: STANDARD BULLETIN (EHWACHS) (P4)

DESIGNED BY: BJ
 DRAWN BY: MVM
 DATE: 9/20/09
 SHEET: 1/12
 PROJECT: MCFP 17

NO. 77-000-60



P/N 77-260-12
KIT, DIESEL SKID POWER PACK - NO HYDRAULICS



P/N 77-260-13
KIT, DIESEL SKID POWER PACK - W/ HYDRAULICS

POWER PACK OPTIONS (CHOOSE ONE)



P/N 77-432-02
350 GALLONS SPOILS TANK



P/N 77-431-02-00
250 GALLONS SPOILS TANK

SPOILS TANK OPTIONS (CHOOSE ONE)



P/N 77-432-02-00
350 GALLONS SPOILS TANK



P/N 77-260-00
ERV-750 WITH BLUE TOOTH FOR VMS KIT

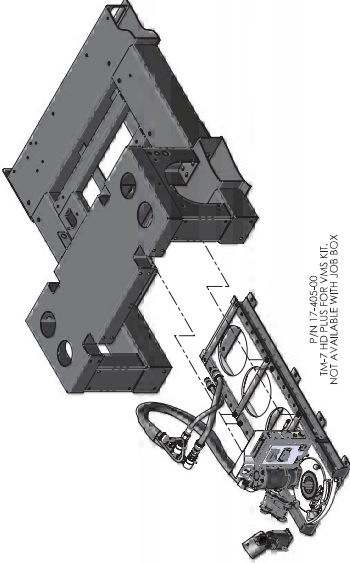

P/N 77-405-00
KIT, VALVE MACHINE
NOT AVAILABLE WITH JOB BOX

VALVE MACHINE(S) OPTIONS



P/N 77-402-01
HC-100 - VITALS CONTROLLER KIT - N-AMER

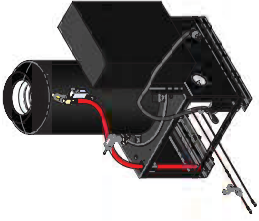

P/N 77-41-05
WATER HEATER - VMS KIT

OTHER OPTIONS

DESCRIPTION	PART NUMBER	NOTES
AVAILABLE OPTIONS		
POWER PACK (CHOOSE ONE)		
KIT, DIESEL SKID POWER PACK - NO HYDRAULICS	77-260-12	
KIT, DIESEL SKID POWER PACK - W/ HYDRAULICS	77-260-13	REQUIRED FOR TM7 P/N 17-405-00, ERV-750 P/N 79-404-00 AND HYDRAULIC HOSE REEL P/N 77-260-13 FOR INSTALLATION.
SPOILS TANK (CHOOSE ONE)		
150 GALLON SPOILS TANK	77-432-02	
250 GALLON SPOILS TANK	77-431-02-00	
350 GALLON SPOILS TANK	77-432-02-00	
VALVE MACHINE(S)		
ERV-750 WITH BLUE TOOTH FOR VMS KIT	79-404-00	REQUIRES POWER PACK - W/ HYDRAULICS P/N 77-260-13 FOR INSTALLATION
TM7 HD PLUS WITH BLUE TOOTH FOR VMS KIT	17-405-00	N/A IF JOB BOX P/N 77-409-00 INSTALLED
HC-100 - VITALS CONTROLLER KIT - N-AMER	77-402-01	REQUIRES POWER PACK - W/ HYDRAULICS P/N 77-260-13 FOR INSTALLATION
LX FEATURES		
LIGHT BAR KIT	77-409-00	
JOB BOX FOR VMS KIT	77-409-00	N/A IF TM7 P/N 17-405-00 INSTALLED
HYDRAULIC HOSE REEL KIT, BOTTOM ROLLER	77-413-05	REQUIRES POWER PACK - W/ HYDRAULICS P/N 77-260-13 FOR INSTALLATION
OTHER OPTIONS		
HOT WATER HEATER FOR VMS KIT	77-41-02	

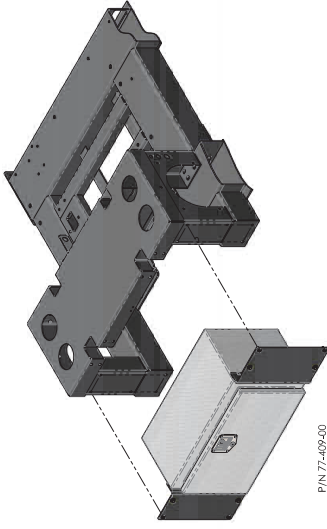

P/N 77-409-00
JOB BOX FOR VMS KIT
NOT AVAILABLE WITH TM7



P/N 77-409-00
LIGHT BAR KIT



P/N 77-413-05
HYDRAULIC HOSE REEL KIT, BOTTOM ROLLER

WACHS		E.H. WACHS	
6050 Technology Parkway Waco, TX 76798-3608 WWW.WACHS.COM		6050 Technology Parkway Waco, TX 76798-3608 WWW.WACHS.COM	
REV: STANDARD BUILDER (DIESEL-VMS) (RH)	REV: STANDARD BUILDER (DIESEL-VMS) (RH)	DATE: 01/20/19	DATE: 01/20/17
DESIGNED BY: B.J.	DESIGNED BY: B.J.	APPROVED BY: M.W.M.	APPROVED BY: M.W.M.
SCALE: 1:8	SCALE: 1:8		
DRAFTING		DRAFTING	
DATE: 01/20/19	DATE: 01/20/19	DATE: 01/20/19	DATE: 01/20/17
D		D	
77-000-60		77-000-60	
A		A	

LX FEATURES

REV.	DESCRIPTION	DATE	APP.
A	NEW RELEASE ECO BOST	9/13/2019	EMW

REVISION HISTORY	
------------------	--

10. VIEWS SHOW OPTIONAL EQUIPMENT:
 ERV-750 WITH BLUECOOL KIT P/N 79-404-00
 GAS POWER PACK KIT P/N 77-280-13
 SERVICE LIGHT PACKAGE P/N 77-420-00
 HYDRAULIC HOSE REEL KIT P/N 77-415-85

9. CUSTOMER AND UPGRADES ARE RESPONSIBLE FOR NOT WEIGHTING (GVWR), ALL PASSENGERS, EQUIPMENT, FUEL, VACUUM SPOILS, WATER, AND CARGO MUST BE ACCOUNTED FOR. UPGRADES SHALL SUPPLY A LABEL WITH GVWR AND COMPLETED VEHICLE WEIGHT PLACED ON THE VEHICLE ABOVE ITS GVWR. SPOILS AND WATER WEIGHTS FOR THE SUPPLIED VAS CONFIGURATION ARE PROVIDED ON THE VAS. SEE SHEET 6 FOR LABEL INFORMATION AND PLACEMENT.

NOTES:
 1. MATERIAL PER COMPONENT
 2. APPROX WEIGHTS SEE WEIGHT AND CENTER OF GRAVITY TABLES
 3. APPROX WEIGHTS SEE WEIGHT AND CENTER OF GRAVITY TABLES
 4. LEGEND USED FOR COMBINATION OF EXPLODED LINE
 5. SEE SHEET 15 FOR FLEETING SCHEMATIC.
 6. SEE SHEET 13 FOR HYDRAULIC SCHEMATIC.
 7. SEE SHEET 16 FOR PRESSURE WASHER SYSTEM SCHEMATIC.
 8. WEIGHT OF SKID WITH FULL SPOILS AND FULL WATER.

11 X 1/2" GRADE 8 BOLTS & 7X 1/2" GRADE 8 BOLTS & NUTS REQUIRED FOR MOUNTING. SEE NOTE 8.

WEIGHT AND CENTER OF GRAVITY TABLE FOR MIN WEIGHT CONFIGURATION, INSTALLED: 150 GAL SPOILS TANK, 100 GAL WATER TANK, 100 GAL FUEL TANK, 100 GAL HYDRAULIC RESERVOIR ON HPU FULL, ANTI-FREEZE TANK FULL. 77-433-02, NO VALVE MACHINE OPTIONS, 1X FEATURES OR HOT WATER HEATER, INSTALLED.

WEIGHT AND CENTER OF GRAVITY TABLE FOR MAX WEIGHT CONFIGURATION, INSTALLED: 150 GAL SPOILS TANK, 100 GAL WATER TANK, 100 GAL FUEL TANK, 100 GAL HYDRAULIC RESERVOIR ON HPU FULL, ANTI-FREEZE TANK FULL. P/N: 77-432-00-04, ERV-750 KIT P/N: 79-404-00, TM-7 HD PLUS KIT P/N: 77-405-00, HC-100 VITALS COMPACTOR KIT P/N: 77-422-00, LIGHT BAR KIT P/N: 77-420-00, HYDRAULIC HOSE REEL KIT P/N: 77-415-85, BRIDGEMAN WATER HEATER, NOT INSTALLED.

SEE DRAWING 77-000-55 FOR 250 GALLON SPOILS TANK WEIGHT AND CENTER OF GRAVITY

SEE NOTE 9

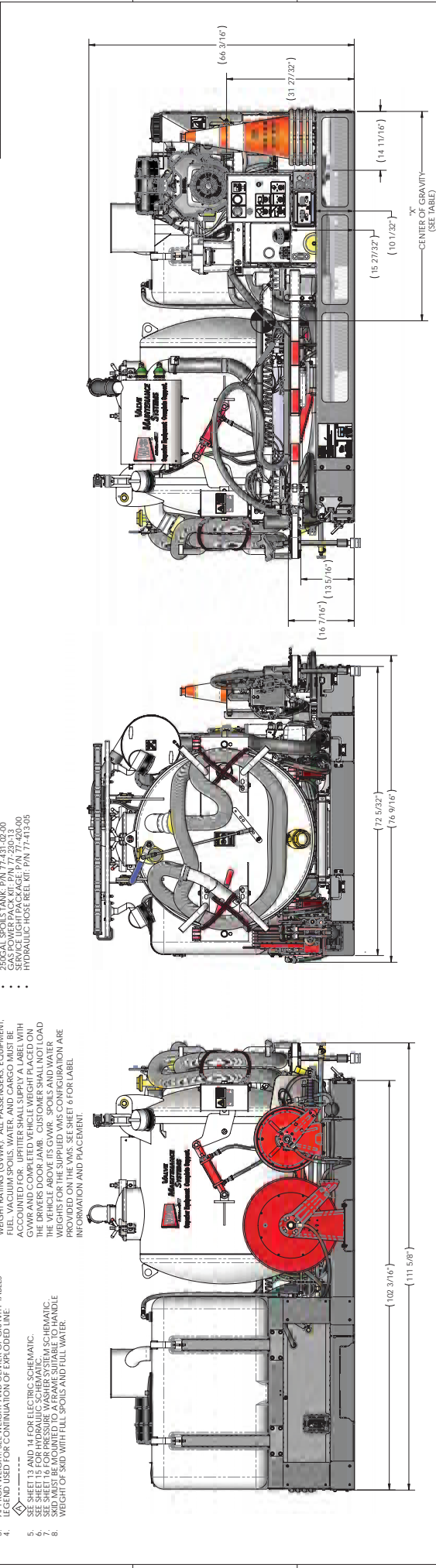

150 GAL SPOILS TANK	100 GAL WATER TANK "X"	(INCHES), APPROX	WEIGHT APPROX. (LBS)
EMPTY	54"	3160	
FULL (WATER)	47 5/8"	3995	
EMPTY	63 1/8"	4611	
FULL (WATER)	57 1/8"	5446	

350 GAL SPOILS TANK	100 GAL WATER TANK "X"	(INCHES), APPROX	WEIGHT APPROX. (LBS)
EMPTY	53 3/4"	4246	
FULL (WATER)	49 1/2"	5081	
EMPTY	62 1/2"	6772	
FULL (WATER)	58 5/8"	7606	

WEIGHT AND CENTER OF GRAVITY TABLE FOR MIN WEIGHT CONFIGURATION, INSTALLED: 150 GAL SPOILS TANK, 100 GAL WATER TANK, 100 GAL FUEL TANK, 100 GAL HYDRAULIC RESERVOIR ON HPU FULL, ANTI-FREEZE TANK FULL. 77-433-02, NO VALVE MACHINE OPTIONS, 1X FEATURES OR HOT WATER HEATER, INSTALLED.

WEIGHT AND CENTER OF GRAVITY TABLE FOR MAX WEIGHT CONFIGURATION, INSTALLED: 150 GAL SPOILS TANK, 100 GAL WATER TANK, 100 GAL FUEL TANK, 100 GAL HYDRAULIC RESERVOIR ON HPU FULL, ANTI-FREEZE TANK FULL. P/N: 77-432-00-04, ERV-750 KIT P/N: 79-404-00, TM-7 HD PLUS KIT P/N: 77-405-00, HC-100 VITALS COMPACTOR KIT P/N: 77-422-00, LIGHT BAR KIT P/N: 77-420-00, HYDRAULIC HOSE REEL KIT P/N: 77-415-85, BRIDGEMAN WATER HEATER, NOT INSTALLED.

SEE DRAWING 77-000-55 FOR 250 GALLON SPOILS TANK WEIGHT AND CENTER OF GRAVITY

SEE NOTE 9

11 X 1/2" GRADE 8 BOLTS & 7X 1/2" GRADE 8 BOLTS & NUTS REQUIRED FOR MOUNTING. SEE NOTE 8.

WEIGHT AND CENTER OF GRAVITY TABLE FOR MIN WEIGHT CONFIGURATION, INSTALLED: 150 GAL SPOILS TANK, 100 GAL WATER TANK, 100 GAL FUEL TANK, 100 GAL HYDRAULIC RESERVOIR ON HPU FULL, ANTI-FREEZE TANK FULL. 77-433-02, NO VALVE MACHINE OPTIONS, 1X FEATURES OR HOT WATER HEATER, INSTALLED.

WEIGHT AND CENTER OF GRAVITY TABLE FOR MAX WEIGHT CONFIGURATION, INSTALLED: 150 GAL SPOILS TANK, 100 GAL WATER TANK, 100 GAL FUEL TANK, 100 GAL HYDRAULIC RESERVOIR ON HPU FULL, ANTI-FREEZE TANK FULL. P/N: 77-432-00-04, ERV-750 KIT P/N: 79-404-00, TM-7 HD PLUS KIT P/N: 77-405-00, HC-100 VITALS COMPACTOR KIT P/N: 77-422-00, LIGHT BAR KIT P/N: 77-420-00, HYDRAULIC HOSE REEL KIT P/N: 77-415-85, BRIDGEMAN WATER HEATER, NOT INSTALLED.

SEE DRAWING 77-000-55 FOR 250 GALLON SPOILS TANK WEIGHT AND CENTER OF GRAVITY

SEE NOTE 9

11 X 1/2" GRADE 8 BOLTS & 7X 1/2" GRADE 8 BOLTS & NUTS REQUIRED FOR MOUNTING. SEE NOTE 8.

WEIGHT AND CENTER OF GRAVITY TABLE FOR MIN WEIGHT CONFIGURATION, INSTALLED: 150 GAL SPOILS TANK, 100 GAL WATER TANK, 100 GAL FUEL TANK, 100 GAL HYDRAULIC RESERVOIR ON HPU FULL, ANTI-FREEZE TANK FULL. 77-433-02, NO VALVE MACHINE OPTIONS, 1X FEATURES OR HOT WATER HEATER, INSTALLED.

WEIGHT AND CENTER OF GRAVITY TABLE FOR MAX WEIGHT CONFIGURATION, INSTALLED: 150 GAL SPOILS TANK, 100 GAL WATER TANK, 100 GAL FUEL TANK, 100 GAL HYDRAULIC RESERVOIR ON HPU FULL, ANTI-FREEZE TANK FULL. P/N: 77-432-00-04, ERV-750 KIT P/N: 79-404-00, TM-7 HD PLUS KIT P/N: 77-405-00, HC-100 VITALS COMPACTOR KIT P/N: 77-422-00, LIGHT BAR KIT P/N: 77-420-00, HYDRAULIC HOSE REEL KIT P/N: 77-415-85, BRIDGEMAN WATER HEATER, NOT INSTALLED.

SEE DRAWING 77-000-55 FOR 250 GALLON SPOILS TANK WEIGHT AND CENTER OF GRAVITY

SEE NOTE 9

11 X 1/2" GRADE 8 BOLTS & 7X 1/2" GRADE 8 BOLTS & NUTS REQUIRED FOR MOUNTING. SEE NOTE 8.

WEIGHT AND CENTER OF GRAVITY TABLE FOR MIN WEIGHT CONFIGURATION, INSTALLED: 150 GAL SPOILS TANK, 100 GAL WATER TANK, 100 GAL FUEL TANK, 100 GAL HYDRAULIC RESERVOIR ON HPU FULL, ANTI-FREEZE TANK FULL. 77-433-02, NO VALVE MACHINE OPTIONS, 1X FEATURES OR HOT WATER HEATER, INSTALLED.

WEIGHT AND CENTER OF GRAVITY TABLE FOR MAX WEIGHT CONFIGURATION, INSTALLED: 150 GAL SPOILS TANK, 100 GAL WATER TANK, 100 GAL FUEL TANK, 100 GAL HYDRAULIC RESERVOIR ON HPU FULL, ANTI-FREEZE TANK FULL. P/N: 77-432-00-04, ERV-750 KIT P/N: 79-404-00, TM-7 HD PLUS KIT P/N: 77-405-00, HC-100 VITALS COMPACTOR KIT P/N: 77-422-00, LIGHT BAR KIT P/N: 77-420-00, HYDRAULIC HOSE REEL KIT P/N: 77-415-85, BRIDGEMAN WATER HEATER, NOT INSTALLED.

SEE DRAWING 77-000-55 FOR 250 GALLON SPOILS TANK WEIGHT AND CENTER OF GRAVITY

SEE NOTE 9

11 X 1/2" GRADE 8 BOLTS & 7X 1/2" GRADE 8 BOLTS & NUTS REQUIRED FOR MOUNTING. SEE NOTE 8.

E.H. WACHS
 600 N. Highway 100, Suite 100
 Houston, TX 77060
 Phone: 281-291-1111
 Fax: 281-291-1112
 Website: www.ehwachs.com

STANDARD BUILDER (GAS VAS) (BR)
 DATE: 04/20/19
 SHEET: 1 OF 11
 Dwg No: 77-000-61

NOTES:

1. VIEWS SHOW OPTIONAL EQUIPMENT:

- ERV/750 WITH BLUETOOTH KIT: P/N 79-404-00
- POWER PACK W/HYDRAULICS KIT: P/N 77-230-13
- SHOCK LIGHT PACKAGE: P/N 77-425-05
- HC-100 VITALS CONTROLLER KIT: P/N 79-422-01

3 GALLON ANTI-FREEZE TANK

VALVE KEY STORAGE TRAY

OPTIONAL HC-100 VITALS CONTROLLER KIT: P/N 79-422-01

OPTIONAL ERV/750 WITH BLUETOOTH KIT: P/N 79-404-00

3" X 10' SUCTION HOSE

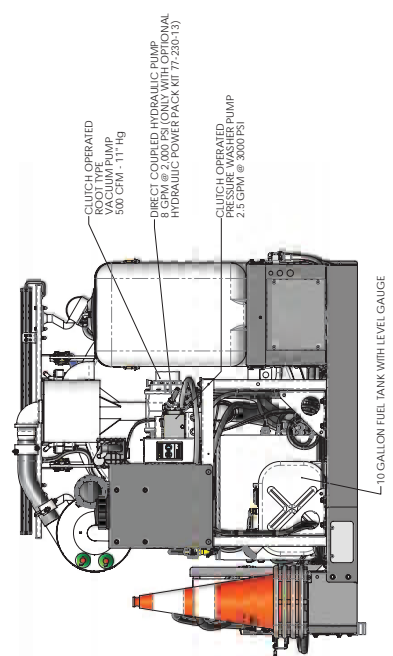

OPTIONS:
150 GAL SPOILS TANK: P/N 77-483-02
250 GAL SPOILS TANK: P/N 77-481-02-00 (SHOWN)
350 GAL SPOILS TANK: P/N 77-482-02-00

2X ADJUSTABLE WORK LIGHTS
OPTIONAL SERVICE LIGHT PACKAGE: P/N 77-420-00

TWIN CHINDER DOOR LATCH SELF-CONTAINED BATTERY POWERED HYDRAULICS

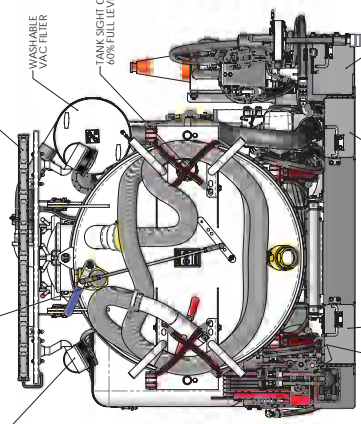

OPTIONAL 7 1/2 HD PLUS KIT: P/N 17-405-00 OR LOCKABLE JOB BOX: KIT: P/N 17-405-08

OPTIONAL HYDRAULIC HOSE REEL KIT: 50' TWIN HOSE KIT: P/N 77-413-05 HTMA CLASS B CIRCUIT

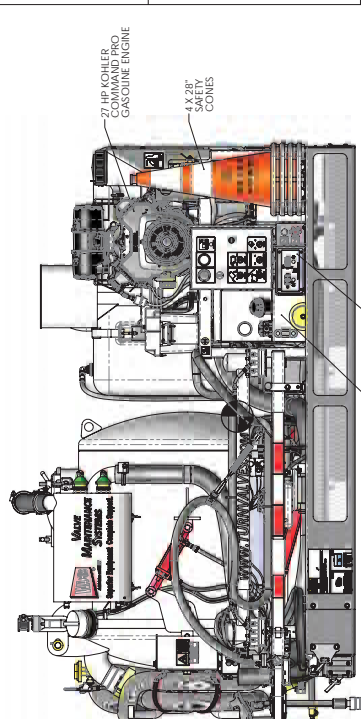

OPTIONAL TEMPERATURE ACTIVATED COOLER WITH OVERHEAT PROTECTION, COOLER WITH OVERHEAT PROTECTION, HYDRAULICS KIT: P/N 77-230-13

CIRCUITRY CONTROLS AVAILABLE WITH HYDRAULICS KIT: P/N 77-413-05 INCLUDING: KEY SWITCH, THROTTLE CHOKE, VACUUM GAUGE, HHO PRESSURE GAUGE, HYDRAULIC OIL TEMPERATURE GAUGE, PRESSURE WASHER CONTROLS, HYDRAULIC CIRCUIT CONTROLS

E.H. WACHS
600 S. HIGHWAY 100
MOUNTAIN VIEW, TEXAS 76150
WWW.EHWACHS.COM

WACHS

STANDARD BUILDER (GAS-VARS) (R/R)

DATE	REV.	DESCRIPTION
01/20/19	1.12	REVISED TO ADD 27 HP KOHLER ENGINE
04/28/19	1.13	REVISED TO ADD 27 HP KOHLER ENGINE
07/20/19	1.14	REVISED TO ADD 27 HP KOHLER ENGINE

77-000-61

NOTES:

1. VIEWS SHOW OPTIONAL EQUIPMENT:
- ERV-760 WITH BLUELOCH KIT, P/N 79-404-00
- 250 GAL SPILLS TANK P/N 77-431-02-00
- SOWER PACK W/WORKING LIGHTS P/N 77-236-13
- HYDRAULIC HOSE REEL KIT P/N 77-413-05
- HC-100 VIALS CONTROLLER KIT P/N 79-422-01

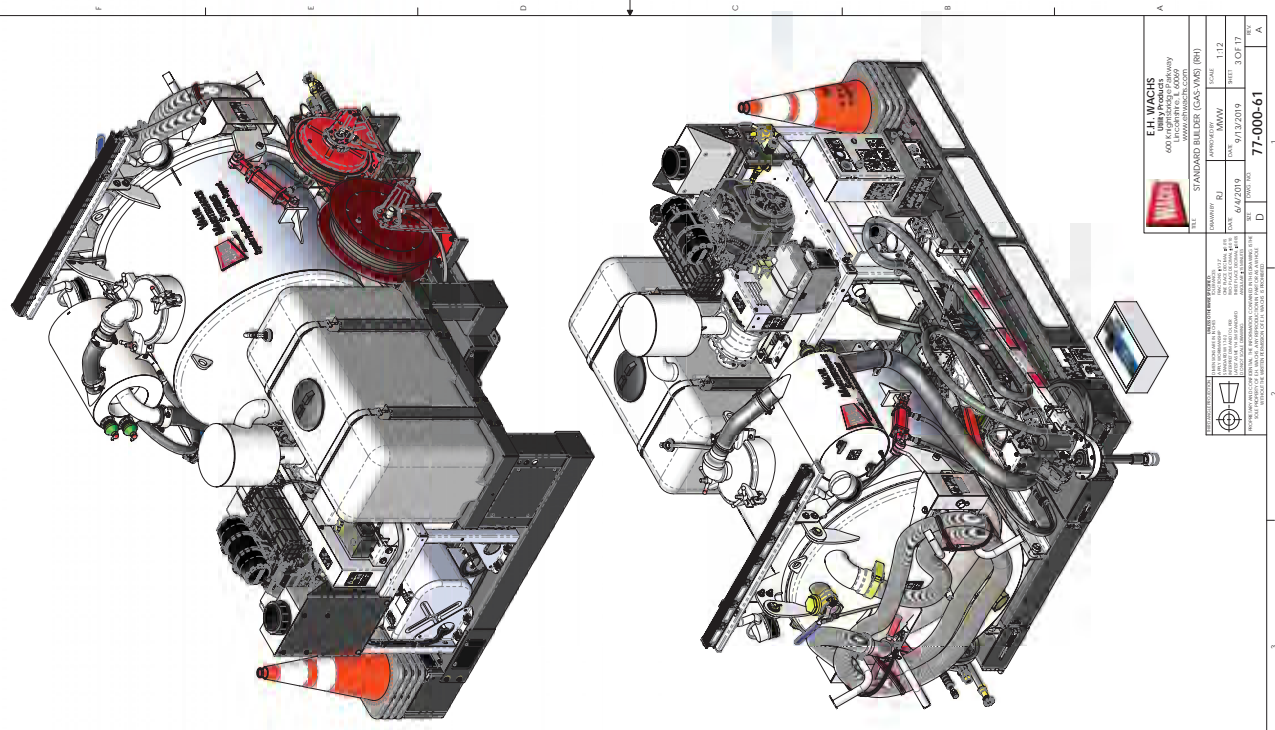

ITEM NO.	PART NUMBER	DESCRIPTION	ESTIMATE LENGTH	QTY.
47	77-290-22	SIDE COVER PANEL		1
48	77-290-24	WELDMENT, KEY BOX		1
49	77-290-28	STRAP, WATER TANK		2
50	77-290-29	STAINLESS STEEL PIPE, 3/4" SCH 40		2
51	77-290-30	STAINLESS STEEL PIPE, 3/8" SCH 40		1
52	77-290-31	LATCH CATCH		2
53	77-290-44	LABEL, 100 GAL WATER TANK		1
54	77-290-46	LABEL, CVWR WARNING		1
55	77-290-00	WELDMENT, VMS SKID RH CONTROLS		1
56	77-291-01	WELDMENT, CONE HOLDER		1
57	77-291-28	2# TRAFFIC CONE		4
58	77-292-12	151 5/16" HOSE ASSEMBLY, 08 FJX-08 FJX-08 HOSE		1
59	77-292-13	43 13/16" HOSE ASSEMBLY, 08 FJX-08 FJX-08 HOSE		1
60	77-312-20	3" X 20' CLEAR SUCTION HOSE ASSEMBLY		1
61	77-406-00	WASH DOWN WAND		1
62	77-408-01	PRESSURE WASHER WAND, W/ROTATING NOZZLE		1
63	77-413-04	ROLLER ASSEMBLY		3
64	77-520-03-29	WIRE HARNESS, SKID POWER PACK		1
65	90-045-04	NUT, 10-24 NYLOCK		18
66	90-051-10	HHCS, 1/4-20 X 3/4 GRADE 5 ZN		12
67	90-051-10	HHCS, 1/4-20 X 1		12
68	90-055-01	NUT, 1/4-20 HEX		2
69	90-055-18	NUT, 1/4-20 ACCR/N		13
70	90-055-52	WASHER, 1/4 SPLIT RING		25
71	90-055-53	WASHER, FLAT, 1/4		25
72	90-061-07	HHCS, 5/16-18 X 3/4		6
73	90-065-01	NUT, 5/16-18 HEX GRADE 8		6
74	90-065-51	WASHER, 5/16 SPLIT RING		6
75	90-065-52	WASHER, 5/16 FLAT		6
76	90-071-10	HHCS, 3/8-16 X 1		48
77	90-071-20	HHCS, 3/8-16 X 2 GR 5 ZN		4
78	90-075-01	NUT, 3/8-16 HEX GR 5 ZN		3
79	90-075-05	NUT, 3/8-16 NYLOCK GR 5 ZN		4
80	90-075-52	WASHER, 3/8 SPLIT RING		52
81	90-075-53	WASHER, 3/8 FLAT		56
82	90-078-84	ADAPTER, -8 (3/4" - 16) M X 3/8" NPT F 90		1
83	90-091-12	HHCS, 1/2-13 X 1 1/4 GRADE 8		14
84	90-095-15	NUT 1/2-13 HEX GR 8 YELLOW ZINC		2
85	90-095-52	WASHER, 1/2 FLAT		14
86	90-095-58	WASHER, 1/2 SPLIT RING		14
87	90-140-07	SHCS, 10-24 X 3/4 SS 8-8		18
88	90-218-15	TEE, 3/4 NPT POLY SCH 80		1
89	90-218-18	PIPPLE, 3/4 NPT, 1 3/8 PVC SCH 80		1
90	90-903-10	CUSHIONED LOOP CLAMP, 1"		1
91	90-903-15	CUSHIONED LOOP CLAMP, 1 1/2"		5
92	90-903-20	CUSHIONED LOOP CLAMP, 2"		3
93	90-903-75	CUSHIONED LOOP CLAMP, 3/4"		3
94	90-903-75	CUSHIONED LOOP CLAMP, 3/4"		1
95	90-1062-58	HHCS, 1/4-20 X 5/8" GR 5 ZN		28
96	90-1583-61-0	CLEVIS ROD END, 1/2 X 13"		2
97	90-651-6-96	THREADED ROD, 1/2-13" X 24"		1
98	90-9132-16-8	BOLT, SHOULDER, 1/2 X 5/8 X SS		1
99	910-8-R-CTK-5	ELBOW, 1/2" MPT X 8 MJC (9-4"-16)		2

ITEM NO.	PART NUMBER	DESCRIPTION	ESTIMATE LENGTH	QTY.
1	68-153-11	HANDLE, CLEVIS ROD		1
2	68-158-16	HOSE CLAMP, CRIMP-23.9 - 27.1 MM		5
3	68-158-57	HOSE CLAMP, S S P/BAL CLOCKWISE		2
4	68-164-03	HOSE, 3" VACUUM - BLACK (6-79FT)		1
5	68-195-50	HOSE, REEL, REELCRAFT, (3/8" X 50') BOTTOM WIND		1
6	68-202-50	OD PLUG, 3/8" X 3/8" NPT F	(8 1/2"), (10 1/2"), (80)	3
7	68-233-00	HOSE, 3/4" IP LOCK ON		2X (9')
8	68-236-00	STRIP, EPDM ADHESIVE BACKED FOAM RUBBER, 2" W X 1/4" THK		2
9	68-236-00	STRIP, EPDM ADHESIVE BACKED FOAM RUBBER, 2" W X 1/4" THK	2X (20 1/2')	2
10	68-242-51	DRAIN VALVE, 3/4" NPT FEMALE INLET X 3/4" MIGHT OUTLET		1
11	68-243-20	ADAPTER, 3/4" NPT M X 3/4" HOSE BARB - NYLON		1
12	68-243-30	ELBOW, 3/4" NPT M X 3/4" HOSE BARB - NYLON		3
13	68-243-70	HOSE TO CAN LEVER ADAPTER, 3/4" CAM X 3/4" GHT F		1
14	68-243-71	CAM LEVER SOCKET, 3/4" X 3/4" NPT F		1
15	68-243-80	ADAPTER, 3/4" BARB X 3/4" NPT F		1
16	68-247-01	SMART BUSHING, 1.38 ID X 1.75 HOLE X 1.25 PANEL		1
17	68-420-02	WAND WELDMENT, 7/8" X 8", 3" HOSE		1
18	68-420-03	WAND WELDMENT, 1 1/4" X 8", 3" HOSE		1
19	68-420-04	WAND WELDMENT, 2 1/2" X 8", 3" HOSE		1
20	77-162-63	100 GALLON WATER TANK ASSEMBLY		1
21	77-175-11	BUMPER, PUSH IN 1/4" HOLE		6
22	77-209-02	CLAMP, 3.5" OD		1
23	77-209-04	U-BOLT, ZINC-PLATED STEEL, 1/4"-20, 1-1/8" ID, 2" HEIGHT		6
24	77-235-94	LATCH CATCH		1
25	77-235-95	LATCH ASSY, RH		1
26	77-236-95	LATCH ASSY, LH		1
27	77-276-11	DOUBLE CHECK VALVE, 3/4" NPT F X 3/4" NPT F		2
28	77-277-50	PVC EDGE TRIM, 0.090" TO 0.190" EDGE THICKNESS (2.3/4')		1
29	77-290-01	WATER TANK BASE WELDMENT		1
30	77-290-02	WELDMENT, WATER TANK STAKE		4
31	77-290-03	HOSE ROLLER GUIDE BRACKET		1
32	77-290-04	WELDMENT, BASKET SIDE		1
33	77-290-05	WELDMENT, LATCH BRACKET		1
34	77-290-06	WAND HOLDER WELDER WELDMENT		1
35	77-290-07	PRESSURE WASHER WAND HOLDER WELDMENT		1
36	77-290-08	WELDMENT, DOOR SKID		2
37	77-290-09	WELDMENT, BASKET DOOR		1
38	77-290-11	WELDMENT, SUPPORT BRACKET		1
39	77-290-12	PIPE SUPPORT BRACKET		2
40	77-290-13	PIPE SUPPORT		2
41	77-290-15	BASKET BACK PANEL		1
42	77-290-16	COVER PLATE		2
43	77-290-17	COVER PLATE		1
44	77-290-18	COVER PLATE		1
45	77-290-20	HOSE BRACKET		1
46	77-290-21	BACK COVER PANEL		1

E.H. WACHS
 605 E. Highway 100, Suite 401
 Waco, TX 76798
 WWW.EHWACHS.COM

STANDARD BUILDER (GAS VES) (RH)

DATE: 04/20/18
 USER: 01/23/2019
 SHEET: 112
 TOTAL SHEETS: 112

77-000-61

NOTES:

- 1. VIEWS SHOW OPTIONAL EQUIPMENT:
- ERV-750 WITH BLUETOOTH KIT: P/N 79-404-00
- 250 GAL. SPILLS TANK: P/N 77-431-02-00
- 350 GAL. SPILLS TANK: P/N 77-432-02-00
- SERVICE LIGHT PACKAGE: P/N 77-420-00
- HYDRAULIC HOSE REEL KIT: P/N 77-413-05
- HD-100 W/AS CONTROLLER KIT: P/N 79-422-01

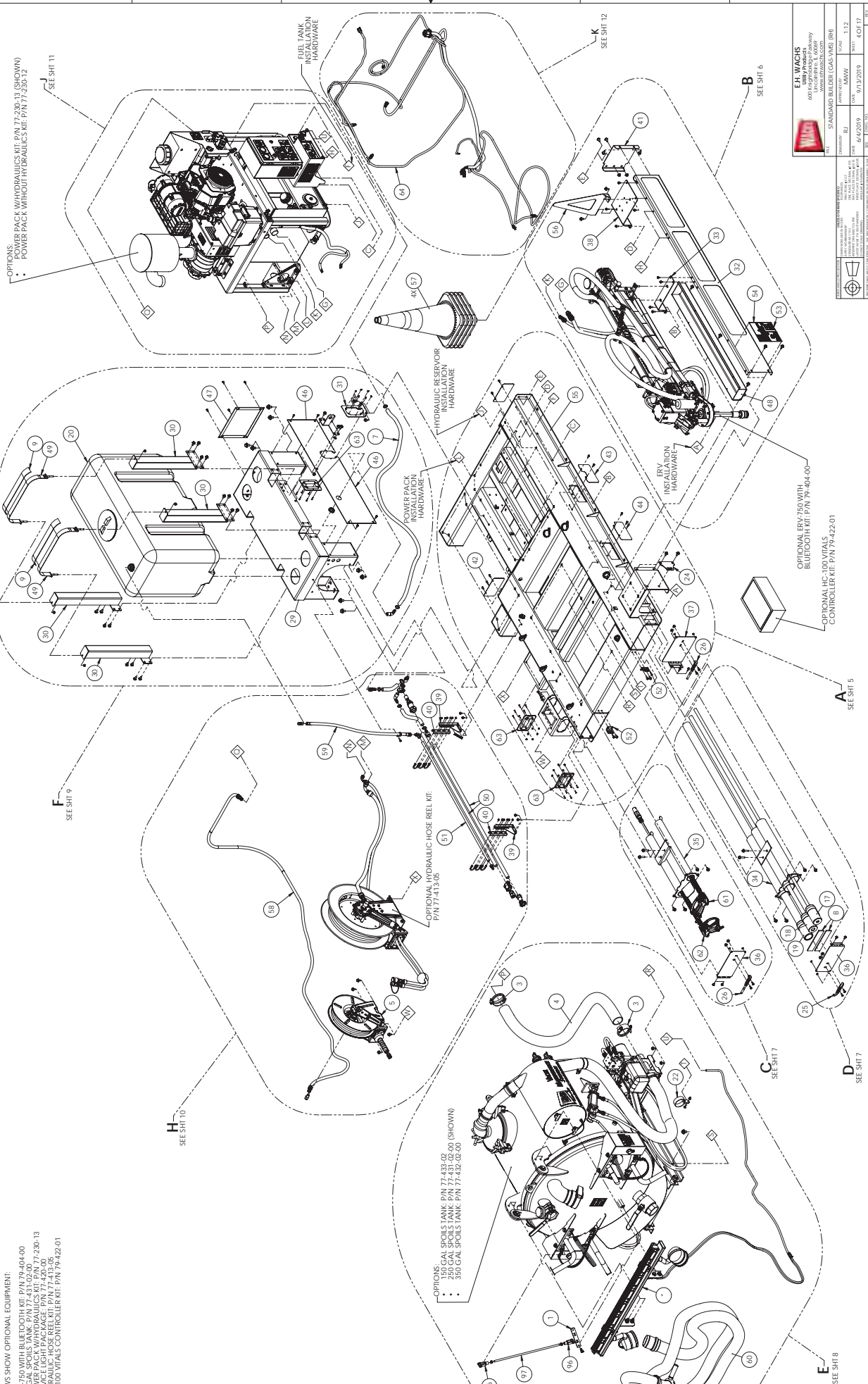

E.H. WACHS
 609 E. Highway 100, Suite 100
 Phoenix, AZ 85024
 480-944-8888
 www.ehwachs.com

REV	DATE	BY	CHKD
1.12	01/20/19	BL	1.12
1.13	01/20/19	BL	1.13
1.14	01/20/19	BL	1.14

77-000-61

REV	DATE	BY	CHKD
1.12	01/20/19	BL	1.12
1.13	01/20/19	BL	1.13
1.14	01/20/19	BL	1.14

OPTIONAL ERV-750 WITH BLUETOOTH KIT: P/N 79-404-00
 OPTIONAL HD-100 W/AS CONTROLLER KIT: P/N 79-422-01

OPTIONAL HYDRAULIC HOSE REEL KIT: P/N 77-413-05

POWER PACK WITH HYDRAULICS KIT: P/N 77-238-13 (SHOWN)

FUEL TANK: P/N 77-430-12

HYDRAULIC RESERVOIR INSTALLATION HARDWARE

OPTIONAL ERV-750 WITH BLUETOOTH KIT: P/N 79-404-00

OPTIONAL HD-100 W/AS CONTROLLER KIT: P/N 79-422-01

77-000-61

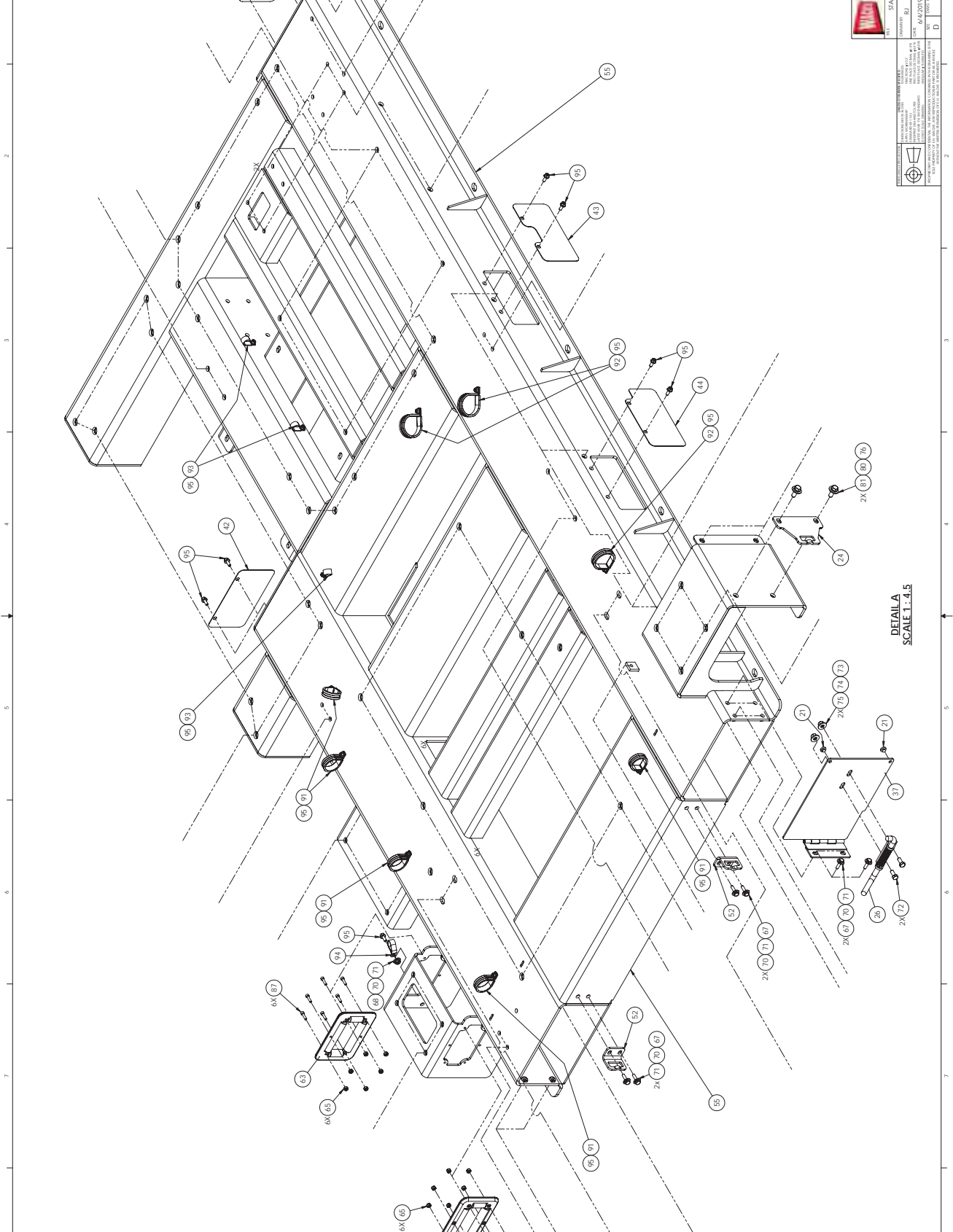

DETAIL A
SCALE 1:4.5

		E.H. WACHS	
STANDARD BUILDER (GAS-VAN) (BR)		SCALE 1:3	
DATE: 01/23/2019	REV: 01/23/2019	SHEET: 5 OF 17	
PROJECT: 77-000-61		DATE: 01/23/2019	
DRAWING: RL		SHEET: 5 OF 17	
DESIGNER: RL		DATE: 01/23/2019	
CHECKER: RL		DATE: 01/23/2019	
APPROVED: RL		DATE: 01/23/2019	
PROJECT: 77-000-61		SHEET: 5 OF 17	
DATE: 01/23/2019		SHEET: 5 OF 17	
PROJECT: 77-000-61		SHEET: 5 OF 17	
DATE: 01/23/2019		SHEET: 5 OF 17	

E.H. WACHS
 600 N. W. 10th Street, Suite 100
 Ft. Lauderdale, FL 33304
 Phone: (954) 562-1111
 Fax: (954) 562-1112
 Email: info@ehwachs.com
 Website: www.ehwachs.com

NOTES

1. VIEW SHOWS OPTIONAL EQUIPMENT.
- ERV/750 WITH BLUETOOTH KIT: PIN 79-404-00

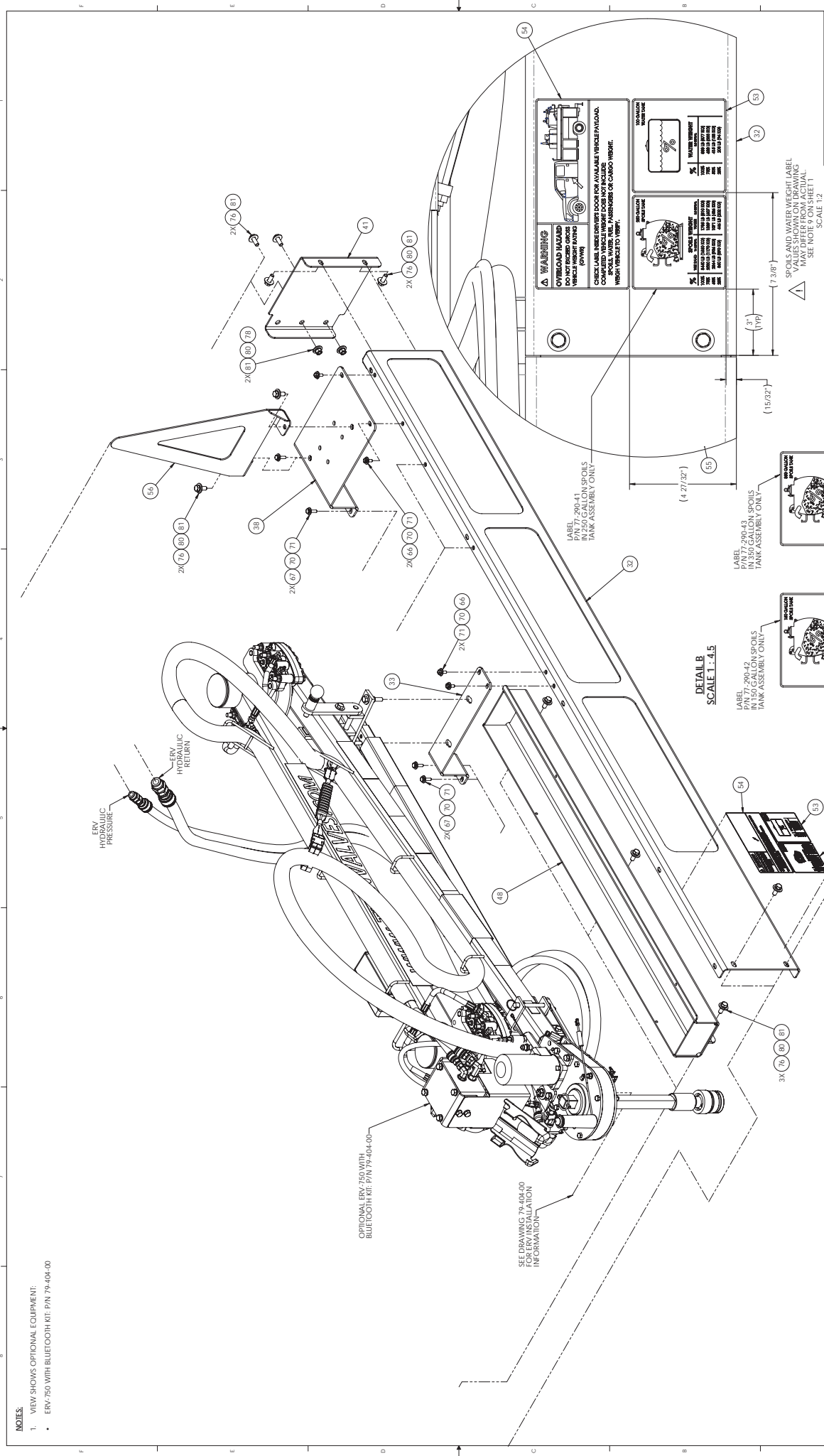

ERV
HYDRAULIC
PRESSURE

ERV
HYDRAULIC
RETURN

OPTIONAL ERV/750 WITH
BLUETOOTH KIT: PIN 79-404-00

SEE DRAWING 79-404-00
FOR
INSTALLATION
INFORMATION

56

2X (76 80 81)

57

2X (67 70 71)

58

2X (61 64 65)

59

2X (66 69 71)

60

2X (61 64 65)

61

2X (76 80 81)

62

63

2X (67 70 71)

64

2X (66 69 70)

65

2X (61 64 65)

66

2X (76 80 81)

67

2X (67 70 71)

68

2X (61 64 65)

69

2X (66 69 70)

70

2X (61 64 65)

71

2X (76 80 81)

72

2X (67 70 71)

73

2X (61 64 65)

74

2X (66 69 70)

75

2X (61 64 65)

76

2X (76 80 81)

77

2X (67 70 71)

78

2X (61 64 65)

79

2X (66 69 70)

80

2X (61 64 65)

81

82

83

84

85

86

87

88

89

90

91

92

93

94

95

96

97

98

99

100

101

102

103

104

105

106

107

108

109

110

111

112

113

114

115

116

117

118

119

120

121

122

123

124

125

126

127

128

129

130

131

132

133

134

135

136

137

138

139

140

141

142

143

144

145

146

147

148

149

150

151

152

153

154

155

156

157

158

159

160

161

162

163

164

165

166

167

168

169

170

171

172

173

174

175

176

177

178

179

180

181

182

183

184

185

186

187

188

189

190

191

192

193

194

195

196

197

198

199

200

201

202

203

204

205

206

207

208

209

210

211

212

213

214

215

216

217

218

219

220

221

222

223

224

225

226

227

228

229

230

231

232

233

234

235

236

237

238

239

240

241

242

243

244

245

246

247

248

249

250

251

252

253

254

255

256

257

258

259

260

261

262

263

264

265

266

267

268

269

270

271

272

273

274

275

276

277

278

279

280

281

282

283

284

285

286

287

288

289

290

291

292

293

294

295

296

297

298

299

300

301

302

303

304

305

306

307

308

309

310

31

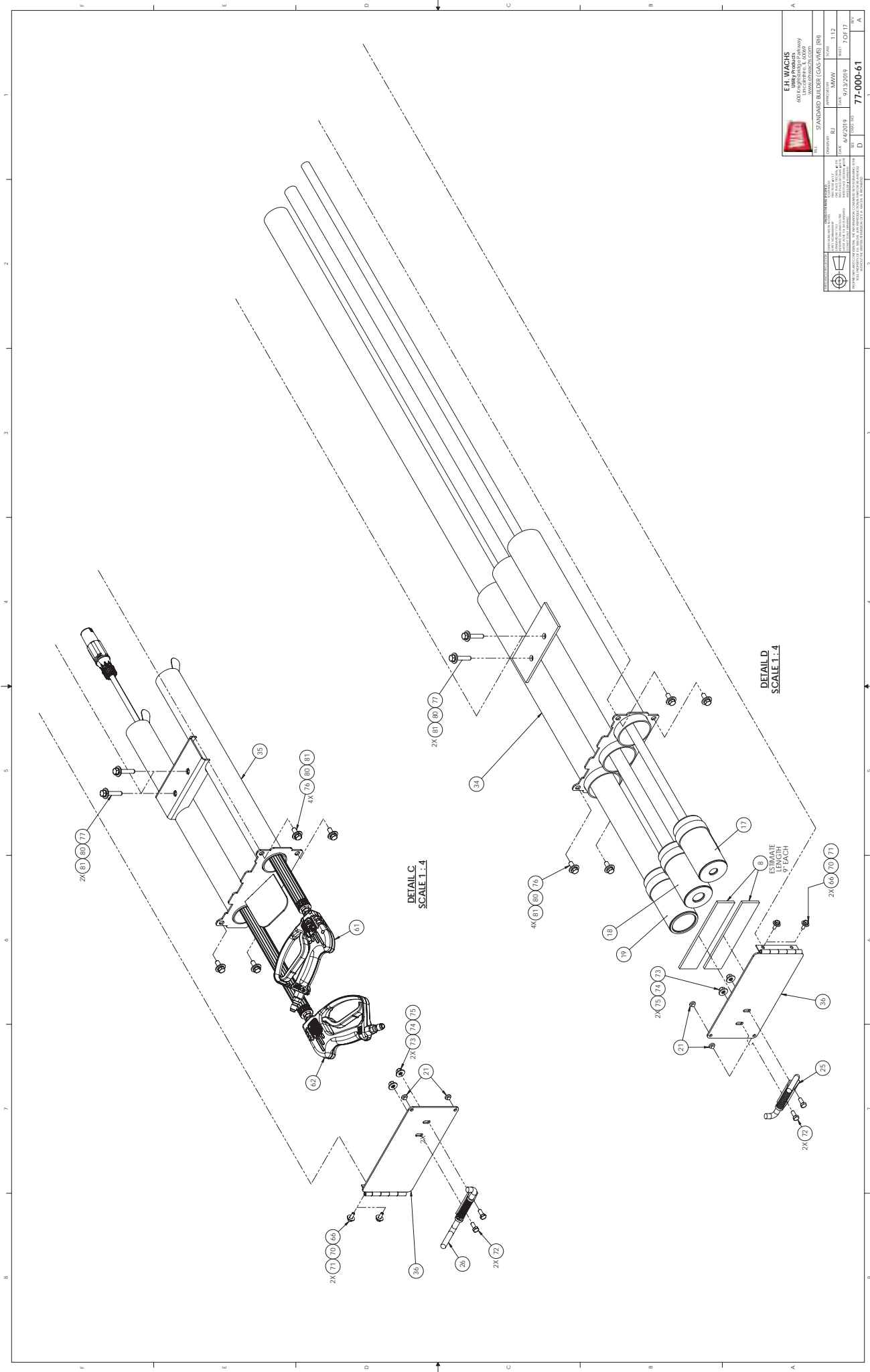

E.H. WACHS		SCALE 1:12	
600 KENNEDY BOULEVARD		SHEET 7 OF 17	
WILMINGTON, MASSACHUSETTS 01890		DATE 04/28/19	
WWW.EHWACHS.COM		REV 0001 000	
PROJECT 77-000-61		D	

THE INFORMATION CONTAINED HEREIN IS THE PROPERTY OF E.H. WACHS & COMPANY, INC. (EHWACHS). IT IS TO BE USED ONLY FOR THE PROJECT AND PURPOSE SPECIFIED HEREIN. NO PART OF THIS DOCUMENT IS TO BE REPRODUCED, STORED IN A RETRIEVING SYSTEM, OR TRANSMITTED IN ANY FORM OR BY ANY MEANS, ELECTRONIC, MECHANICAL, PHOTOCOPYING, RECORDING, OR BY ANY INFORMATION STORAGE AND RETRIEVAL SYSTEM, WITHOUT THE WRITTEN PERMISSION OF EHWACHS.

DETAIL C
SCALE 1:4

DETAIL
SCALE 1:4

8
 SAME
 LENGTH
 9" EACH

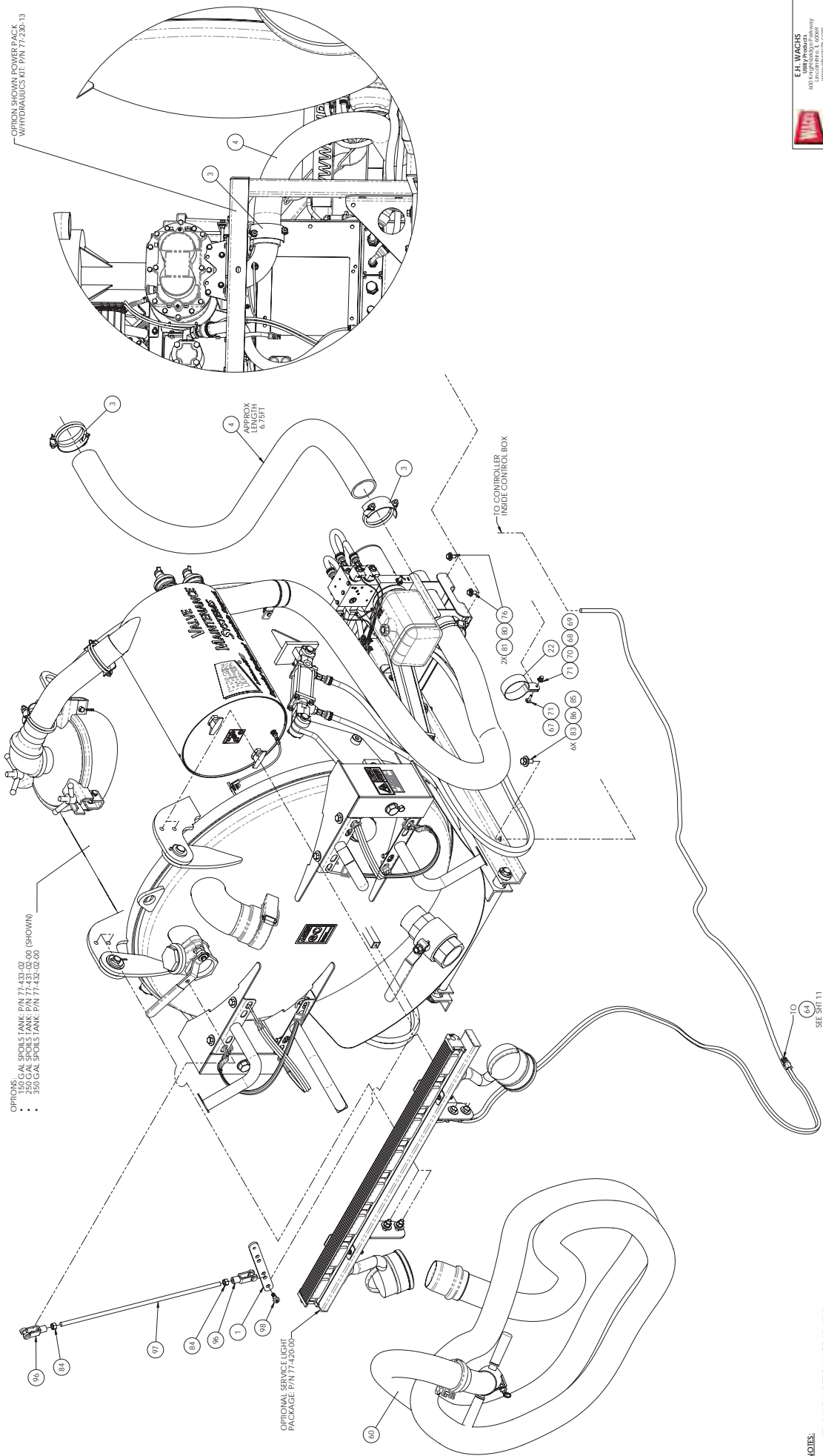

OPTIONS:
 • 64 GAL. SPOOLS TANK: P/N 77-432-02
 • 250 GAL. SPOOLS TANK: P/N 77-431-02-00 (SHOWN)
 • 350 GAL. SPOOLS TANK: P/N 77-432-02-00

OPTIONAL SERVICE LIGHT PACKAGE: P/N 77-420-04

60 CONTROLS ARE INSIDE CONTROL BOX

OPTION SHOWN POWER PACK WITH HYDRAULICS KIT: P/N 77-230-13

E.H. WACHS	
600 E. Highway 100, P.O. Box 100 Wachsville, FL 34787 www.ehwachs.com	
ITEM: STANDARD BUILDER (GAS-VARS) (BR)	SCALE: 1:6
DRAWING: RL	DATE: 01/23/2019
REV: 04/2019	REV: 001/17
REV: 02/01/2020	REV: 002/17
77-000-61	

DETAILS
 SCALE 1:6

64
 SEE SH11

- NOTES:**
1. VIEWS SHOW OPTIONAL EQUIPMENT:
 2. 250 GAL. SPOOLS TANK: P/N 77-431-02-00
 3. POWER PACK WITH HYDRAULICS KIT: P/N 77-230-13
 4. SERVICE LIGHT PACKAGE: P/N 77-420-04

NOTES:

- 1. VIEWS SHOW OPTIONAL EQUIPMENT.
- POWER PACK W/HYDRAULICS KIT: P/N 77-230-13

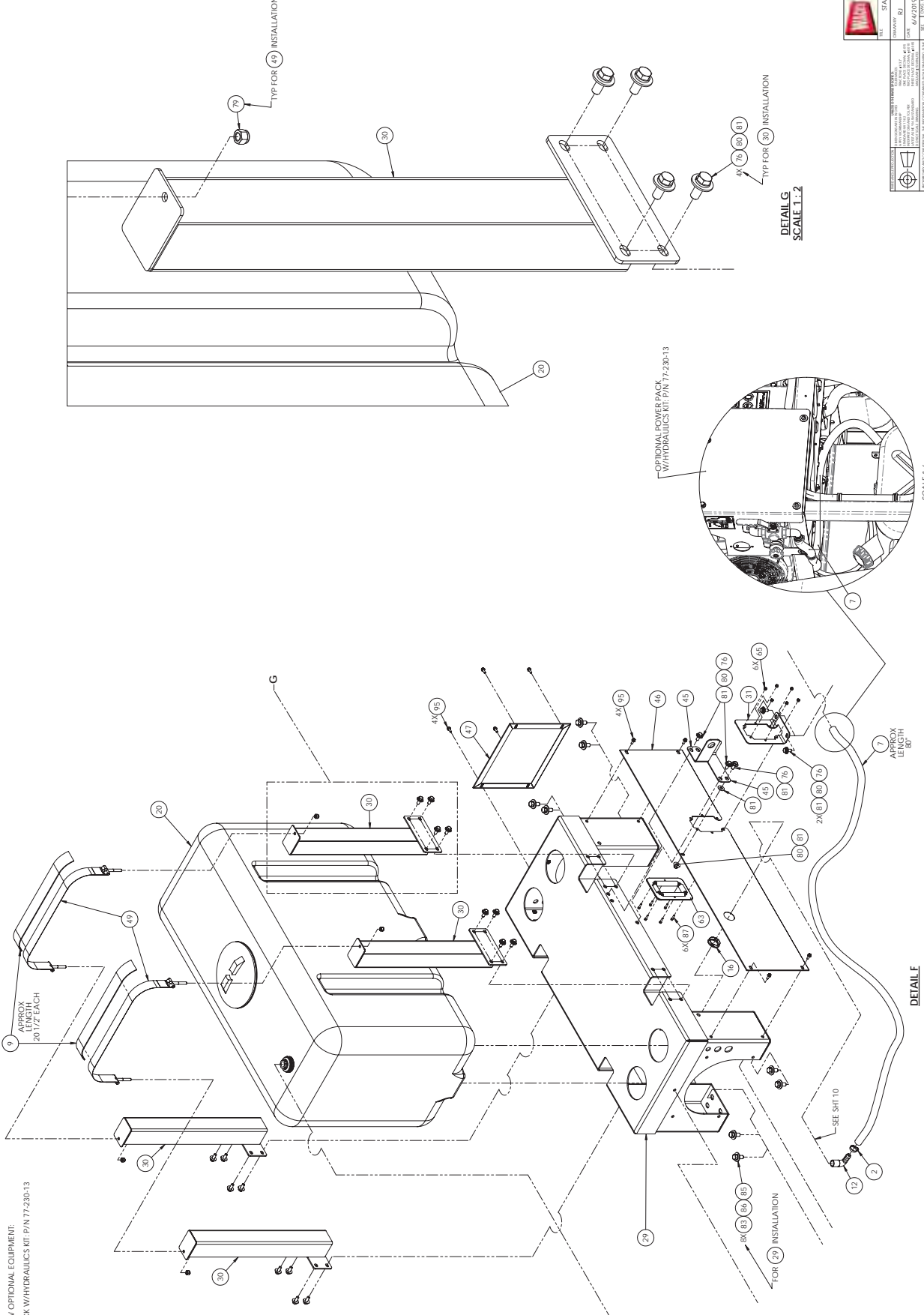

OPTIONAL POWER PACK
W/HYDRAULICS KIT: P/N 77-230-13

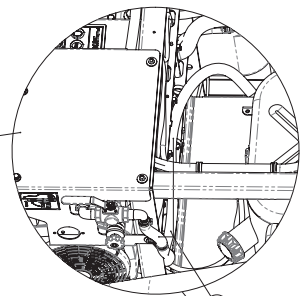

SCALE 1:6

DETAIL G
SCALE 1:2

E.H. WACHS		STANDARD BUILDER (GAS-VANS) (BR)	
600 N. HARRIS BLVD. SUITE 100 MCKINNEY, TX 75069 WWW.EHWACHS.COM		SCALE	1:2
DATE	01/23/2019	SHEET	17
REV	04/28/18	POST	17
BY	02/07/20	77-000-61	
D			

NOTES:

- 1. VIEWS SHOW OPTIONAL EQUIPMENT:
 - POWER PACK W/HYDRAULICS KIT: P/N 77-220-13

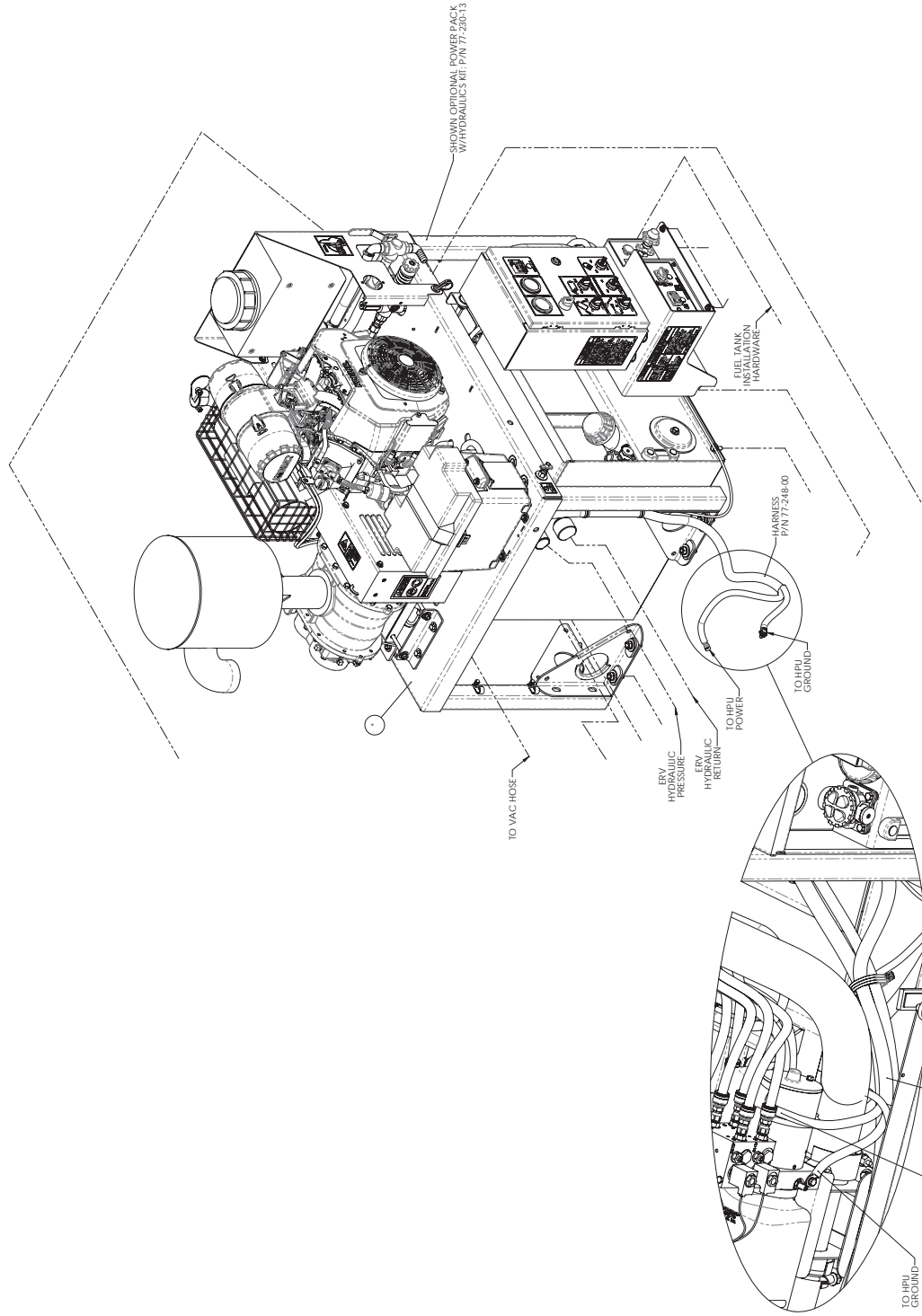

DETAIL

		E.H. WACHS 600 North Highway 100 P.O. Box 100 Wachs, MO 64601 www.ehwachs.com	
REV	STANDARD BUILDER (CAS-VAS) (RH)	SCALE	1:6
DATE	01/23/2019	DESIGNER	RL
DATE	04/22/2019	DRAWN	RL
DATE	02/02/2020	CHKD	RL
DATE	01/07/21	APP'D	RL
D		77-000-61	

NOTES:

- 1. VIEWS SHOW OPTIONAL EQUIPMENT: POWER PACK W/HYDRAULICS KIT: P/N 77-230-13

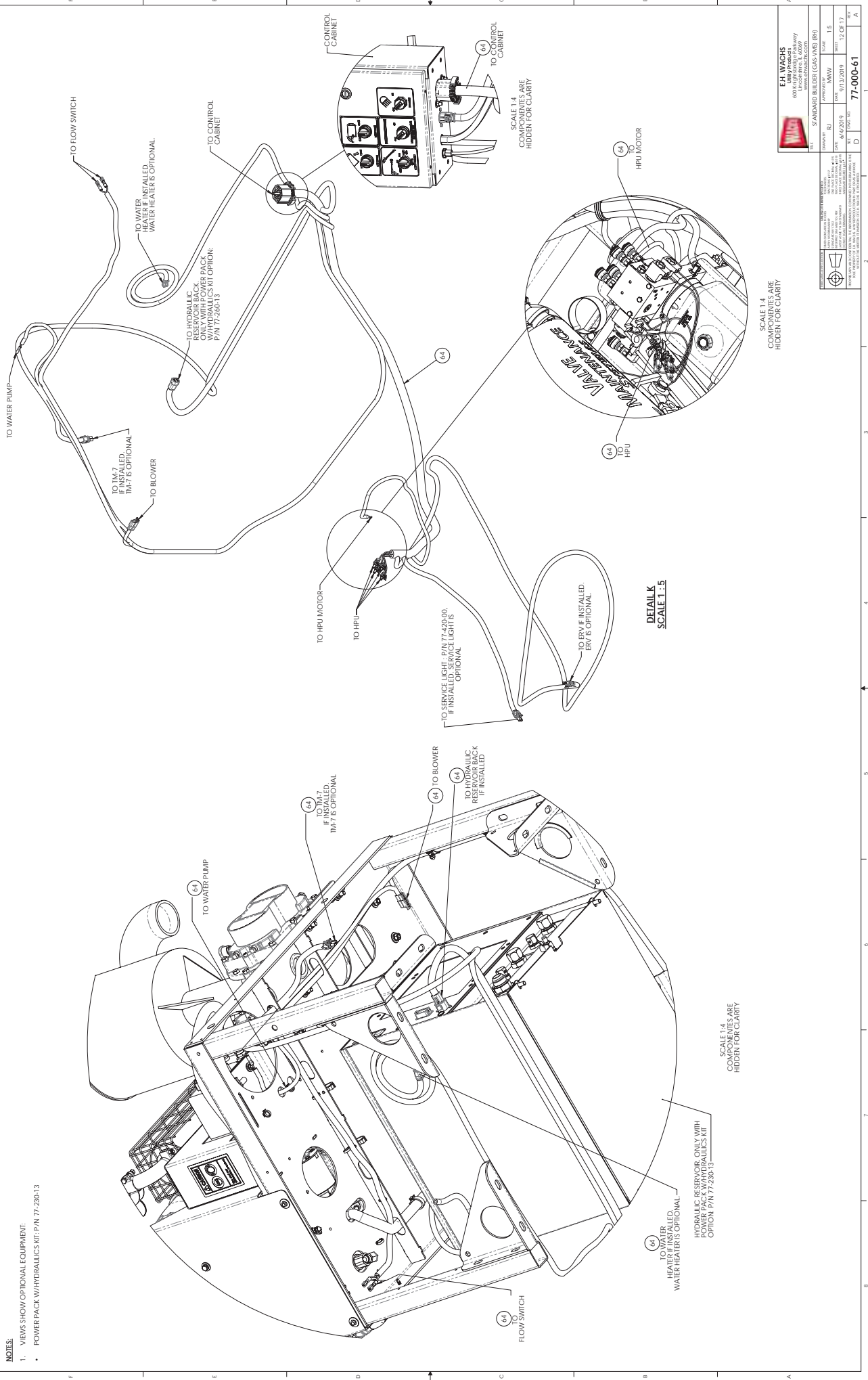

E.H. WACHS
600 E. HIGHWAY 160
MUNICIPALITY OF GAZPACH
MUNICIPALITY OF GAZPACH
WWW.MUNICIPALITYOFGAZPACH.COM

REV	DATE	BY	CHKD
1	07/20/19	BL	LS
2	07/22/19		
3	07/22/19		
4	07/22/19		
5	07/22/19		

E.H. WACHS
600 E. HIGHWAY 160
MUNICIPALITY OF GAZPACH
MUNICIPALITY OF GAZPACH
WWW.MUNICIPALITYOFGAZPACH.COM

REV	DATE	BY	CHKD
1	07/20/19	BL	LS
2	07/22/19		
3	07/22/19		
4	07/22/19		
5	07/22/19		

77-000-61

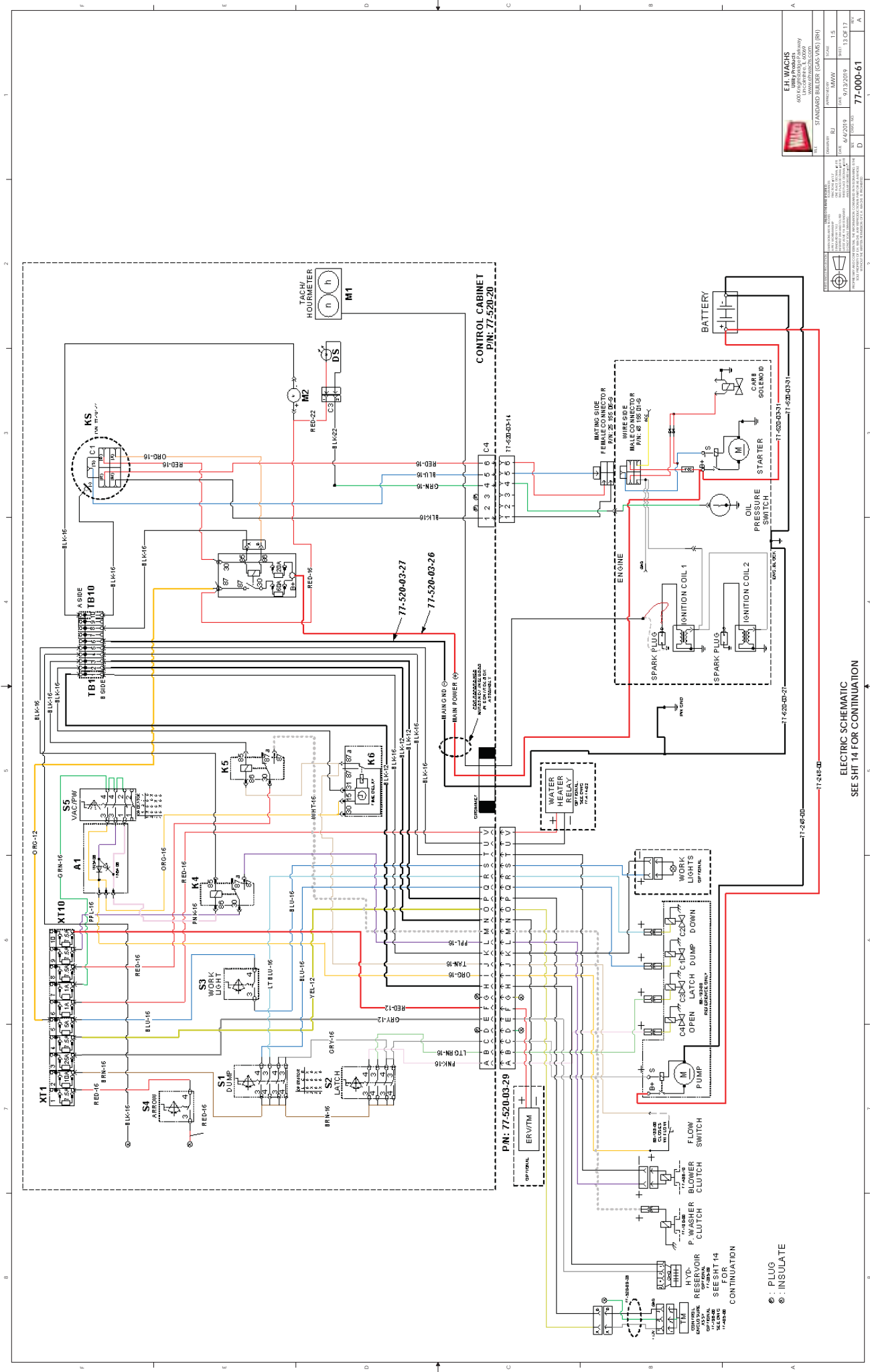

ELECTRIC SCHEMATIC
 SEE SH14 FOR CONTINUATION

⊙ : PLUG
 ⊗ : INSULATE

CONTINUATION
 SEE SH14 FOR CONTINUATION

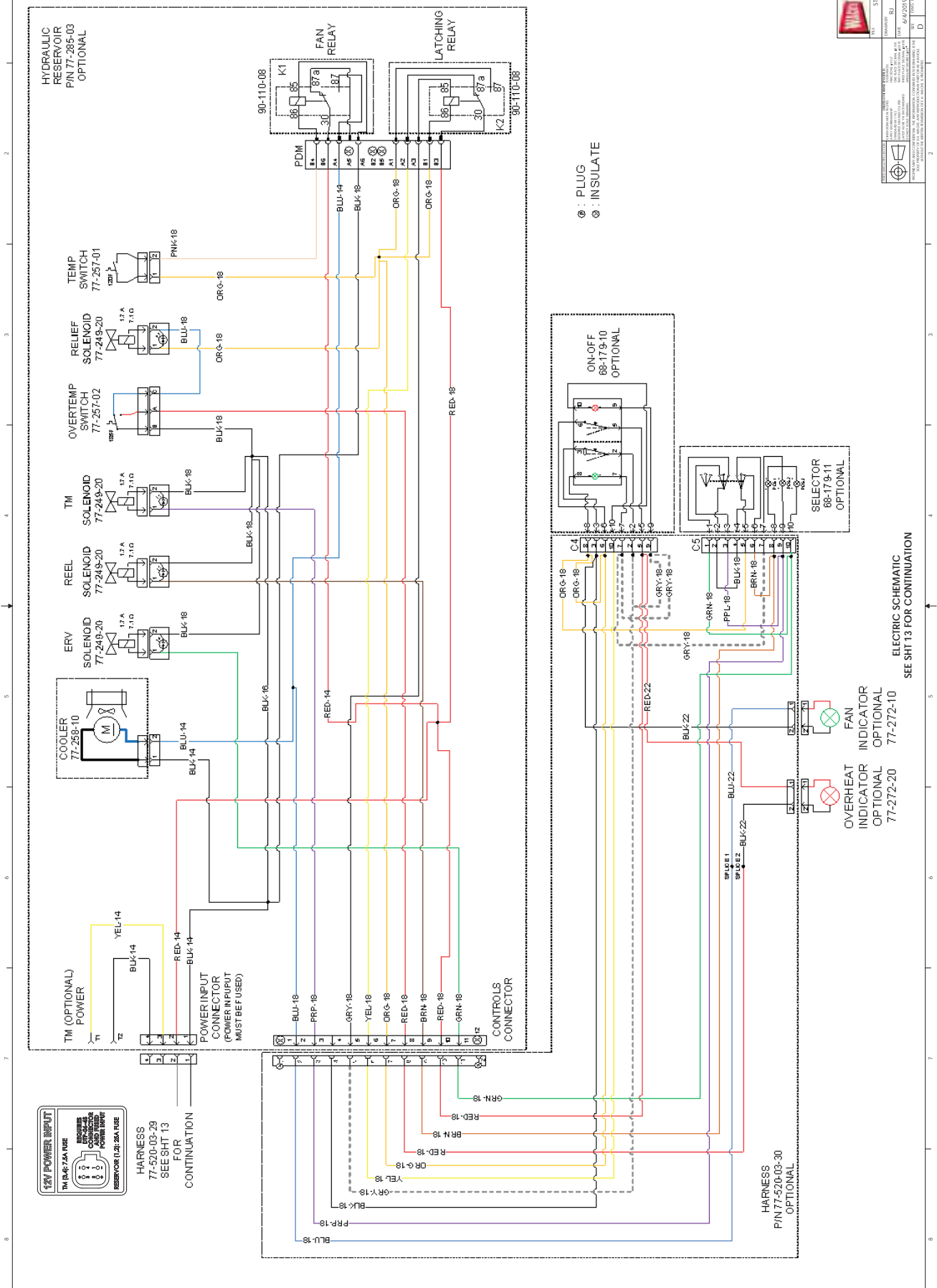

HARNESSES
77-520-03-29
SEE SHT 13
FOR
CONTINUATION

POWER INPUT
CONNECTOR
(POWER INPUT
MUST BE USED)

HARNESSES
P/N 77-520-03-30
OPTIONAL

OVERHEAT
INDICATOR
OPTIONAL
77-272-20

FAN
INDICATOR
OPTIONAL
77-272-10

ELECTRIC SCHEMATIC
SEE SHT 13 FOR CONTINUATION

⊙ PLUG
⊙ INSULATE

E.H. WACHS 600 N. HARRIS BLVD MOUNTAIN VIEW, MO 64061 WWW.WACHSUSA.COM		REV	DATE	BY	CHKD
STANDARD BUILDER (GAS, VMS) (RH)	BL	01/23/2019	1.5		
REV	DATE	BY	CHKD		
77-000-61	D	04/22/2018	1.0		
77-000-61	D	07/07/2007	1.0		

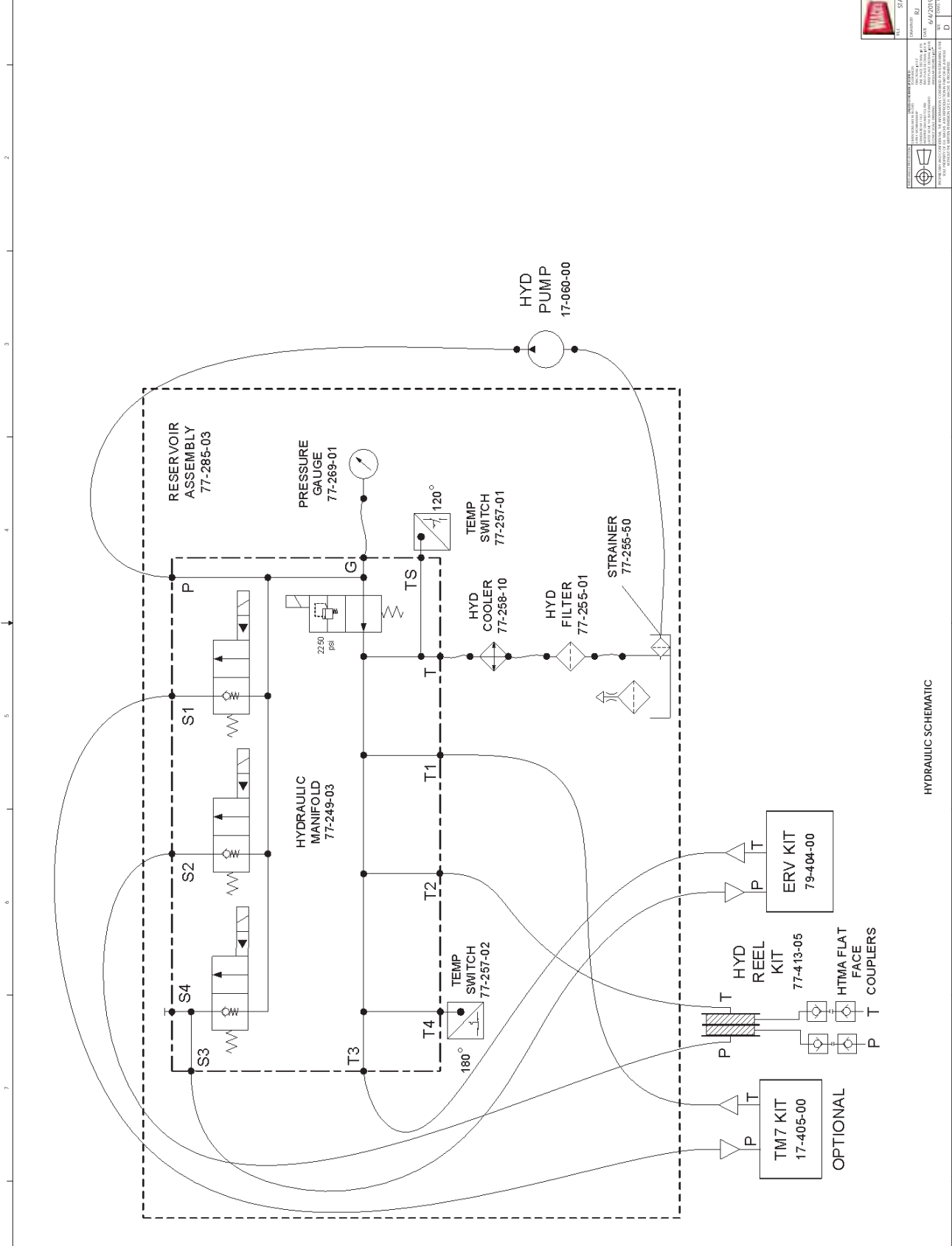

HYDRAULIC SCHEMATIC

		E.H. WACHS 600 North Highway 100 P.O. Box 100 Waco, TX 76788-0100 WWW.EHWACHS.COM	
DRAWING NO. 77-000-61	REV. D	APPROVED FOR MANUFACTURE DATE 01/23/2019	SCALE 1:1
DESIGNED BY 04/28/18	CHECKED BY 05/01/18	DRAWING NO. 77-000-61	SHEET NO. 15 OF 15

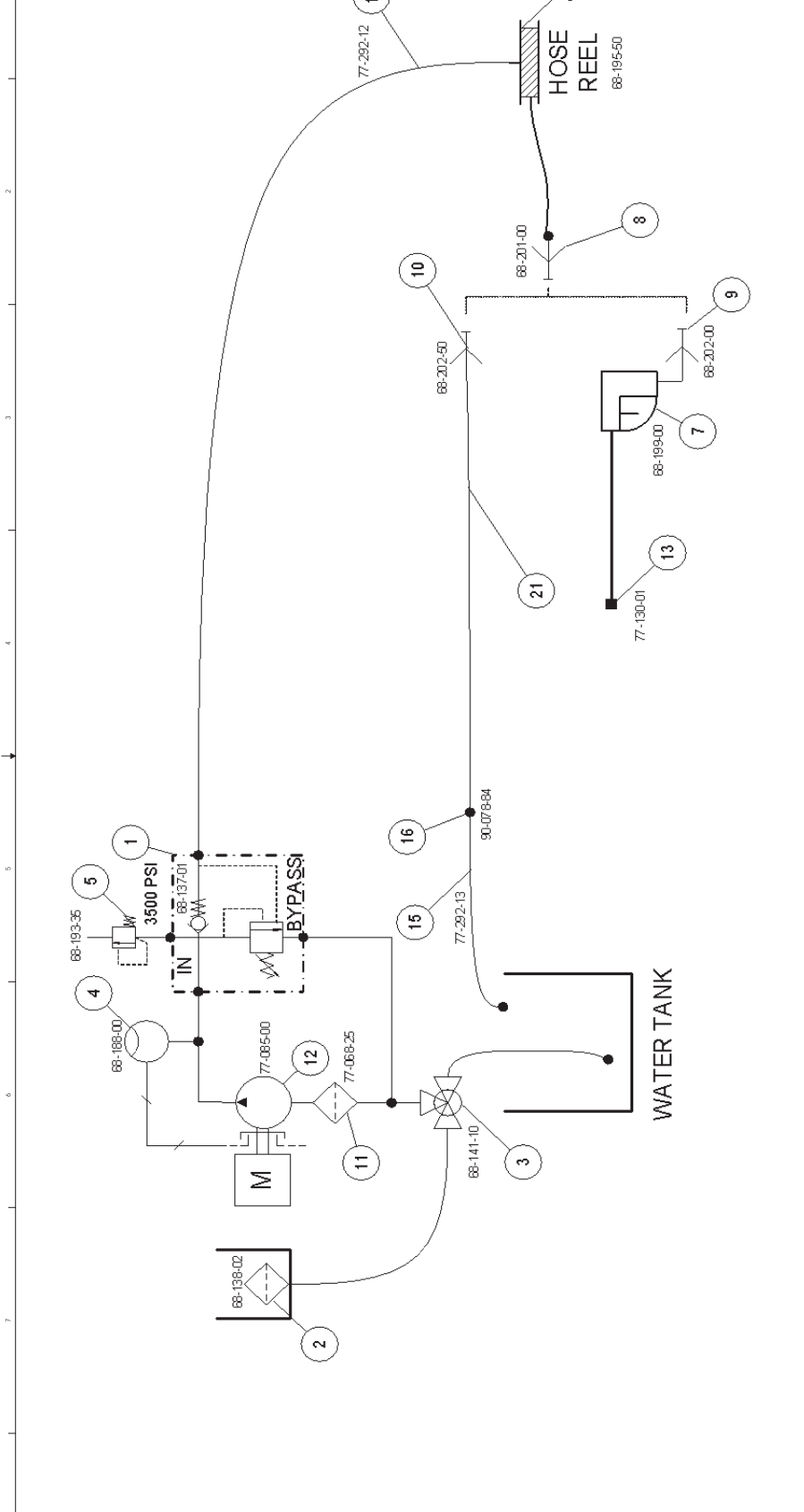

PARTS LIST FOR PRESSURE WASHER SYSTEM SCHEMATICS. REFERENCE ONLY. BALLOONS DO NOT CORRESPOND WITH ROW TABLE ON SHEET 3

SCHEMATIC ITEM	PART NUMBER	DESCRIPTION
1	68-138-01	VALVE, TRAPPED PRESSURE UNLOADER
2	68-138-02	STRAINER
3	68-141-10	BALL VALVE, 3-WAY
4	68-188-00	FLOW SWITCH
5	68-192-35	SAFETY RELIEF, 3500 PSI
6	68-195-50	HOSE REEL
7	68-199-00	SPRAY GUN
8	68-201-00	OD COUPLER, 3/8" X 3/8" NPT-F
9	68-202-00	OD PLUG, 3/8" X 3/8" NPT-M
10	68-202-50	OD PLUG, 3/8" X 3/8" NPT-F
11	77-069-25	STRAINER
12	77-085-00	PUMP PRESSURE WASHER 2.6 GPM, 3000 PSI
13	77-130-01	NOZZLE, .030 X 15 DEGREE
14	77-292-12	151 5/16" HOSE ASSEMBLY, .08 E.I. X .08 F.I. .08 HOSE
15	77-292-13	43 13/16" HOSE ASSEMBLY, .08 E.I. X .08 F.I. .08 HOSE
16	90-076-84	ADAPTER, 8 1/4" - 1.6MM I.D. 3/8" NPT-F 90

PRESSURE WASHER SYSTEM SCHEMATIC

E.H. WACHS
600 E. Highway 100, Suite 100
Mesa, AZ 85205
www.ehwachs.com

REV	STANDARD BUILDER (GAS WAS) (RH)	SCALE	1:12
DATE	01/23/2019	DESIGNED BY	RL
DATE	04/28/18	DRAWN BY	RL
DATE	01/23/2019	CHECKED BY	RL
DATE	01/23/2019	APPROVED BY	RL

77-000-61



P/N 77-290-19
KIT GAS SKID POWER PACK - NO HYDRAULICS



P/N 77-290-13
KIT GAS SKID POWER PACK - W/ HYDRAULICS



P/N 77-433-02
150 GALLONS SPOILS TANK



P/N 77-431-02-00
250 GALLONS SPOILS TANK



P/N 77-432-02-00
350 GALLONS SPOILS TANK



P/N 79-404-00
ERV-750 WITH BLUE TOOTH FOR VMS KIT

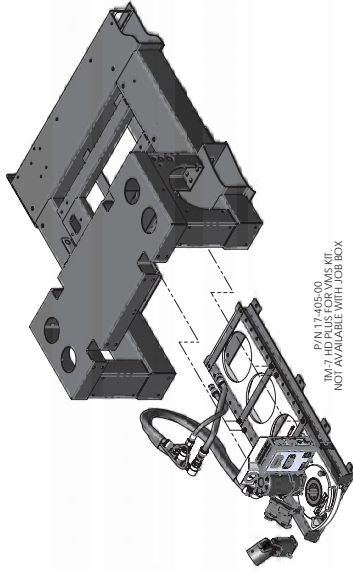

P/N 77-405-00
TM 7-1413-05
NOT AVAILABLE WITH JOB BOX



P/N 79-429-01
HC-100 - VITALS CONTROLLER KIT - N AMER

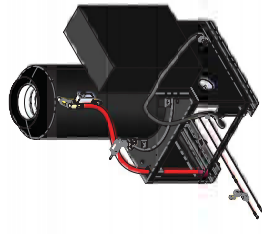

P/N 77-414-03
WATER HEATER - VMS KIT

DESCRIPTION	PART NUMBER	NOTES
AVAILABLE OPTIONS		
POWER PACK (CHOOSE ONE)		
KIT GAS SKID POWER PACK - NO HYDRAULICS	77-290-12	
KIT GAS SKID POWER PACK - W/ HYDRAULICS	77-290-13	REQUIRED FOR TM-7 P/N 17-405-00, ERV-750 P/N 79-404-00 AND HYDRAULIC HOSE REEL P/N 77-413-05 FOR INSTALLATION.
SPOILS TANK (CHOOSE ONE)		
150 GALLON SPOILS TANK	77-433-02	
250 GALLON SPOILS TANK	77-431-02-00	
350 GALLON SPOILS TANK	77-432-02-00	
VALVE MACHINE(S)		
ERV-750 WITH BLUE TOOTH FOR VMS KIT	79-404-00	REQUIRES POWER PACK - W/ HYDRAULICS P/N 77-290-13 FOR INSTALLATION
TM-7 HD PLUS WITH BLUE TOOTH FOR VMS KIT	77-405-00	N/A IF JOB BOX P/N 77-409-00 INSTALLED
HC-100 - VITALS CONTROLLER KIT - N AMER	79-422-01	REQUIRES POWER PACK - W/ HYDRAULICS P/N 77-290-13 FOR INSTALLATION
LX FEATURES		
LIGHT BAR KIT	77-420-00	N/A IF TM-7 P/N 17-405-00 INSTALLED
JOB BOX FOR VMS KIT	77-409-00	REQUIRES POWER PACK - W/ HYDRAULICS P/N 77-290-13 FOR INSTALLATION
HYDRAULIC HOSE REEL KIT - BOTTOM ROLLER	77-419-05	
OTHER OPTIONS		
HCI WATER HEATER FOR VMS KIT	77-414-02	

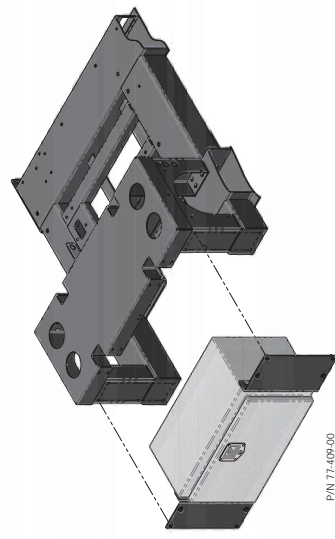

P/N 77-409-00
JOB BOX FOR VMS KIT
NOT AVAILABLE WITH TM-7



P/N 77-420-00
LIGHT BAR KIT



P/N 77-419-05
HYDRAULIC HOSE REEL KIT, BOTTOM ROLLER

E.H. WACHS 600 KENNEDY DRIVE MOUNTAIN VIEW, TEXAS 76051 WWW.EHWACHS.COM	
STANDARD BUILDER (GAS VMS) (BR)	1.8
APPROXIMATE VOLUME	1.8
DATE	01/23/2019
REV	04/28/09
REV	02/02/00
REV	07/01/11
REV	07/01/18
77-000-61	

LX FEATURES

NOTES:

1. MATERIAL: PER COMPONENT
2. FINISH: PER COMPONENT
3. KIT REQUIRES OTHER COMPONENTS / SYSTEMS TO FUNCTION
4. IF STORING OR TRANSPORTING, PACKAGE AND SECURE LOOSE COMPONENTS AND HARDWARE
5. SEE HIGHER LEVEL ASSEMBLY FOR SCHEMATICS AND INTERFACES
6. APPROX WEIGHT: 1169.4 LB

REVISION HISTORY			
REV.	DESCRIPTION	DATE	APP.
A	NEW RELEASE: ECO 3784	9/20/2019	MMW

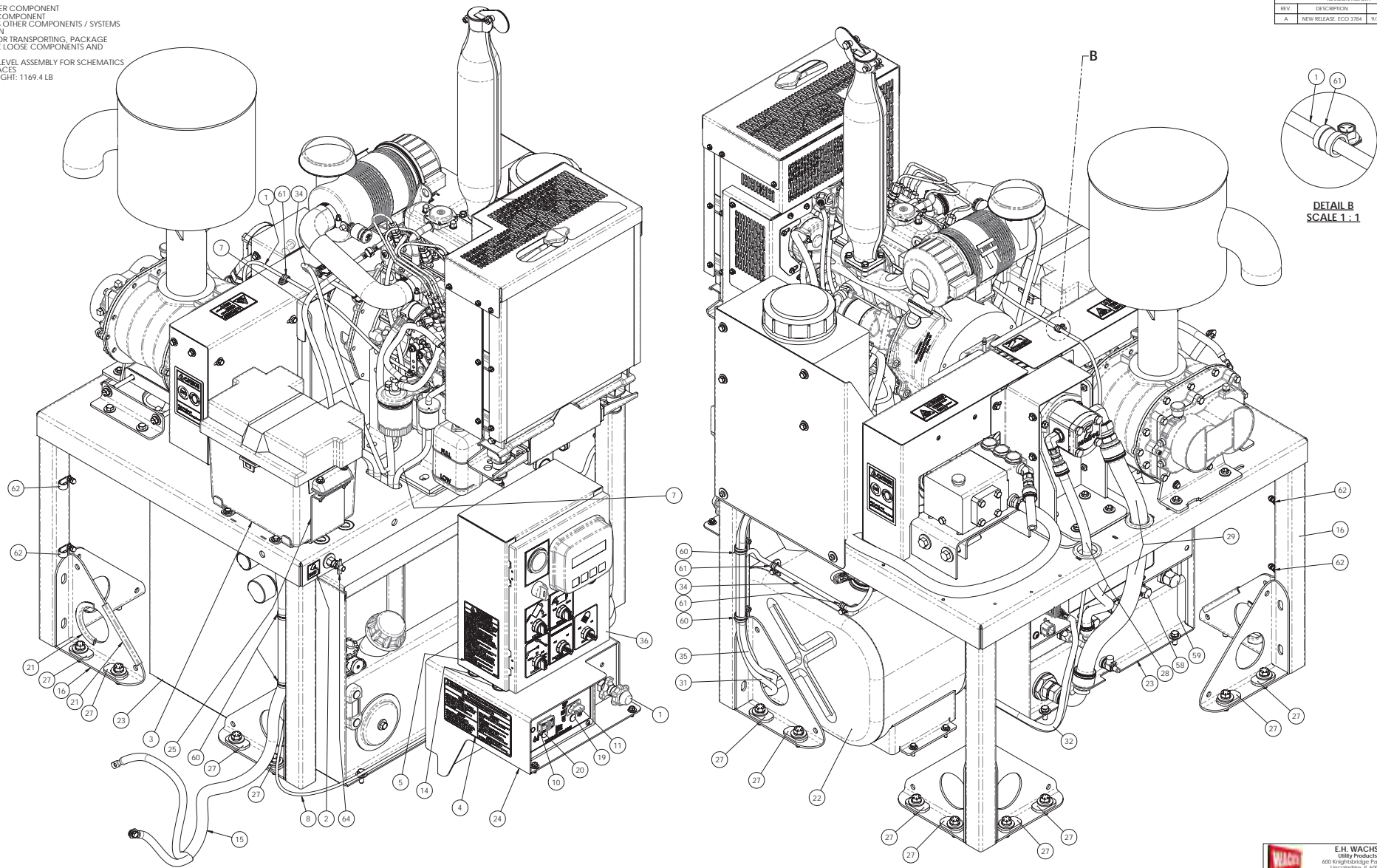

		E. H. WACHS Utility Products 600 Knightbridge Parkway Lincolnshire, IL 60069 www.ehwachs.com	
		KIT, DIESEL SKID POWER PACK	
DRAWN BY: RJ DATE: 4/23/2019	APPROVED BY: MMW DATE: 9/20/2019	SCALE: 1:4 SHEET: 1 OF 7	REV: A
77-260-13			

ITEM NO.	PART NUMBER	DESCRIPTION	QTY.	ESTIMATE LENGTH
1	17-065-01	THROTTLE CABLE X 10'	1	
2	59-131-00	LABEL, CORROSION PROTECTION	1	
3	67-051-00	CASE, BATTERY	1	
4	67-112-00	LABEL, MAINTENANCE SCHEDULE	1	
5	67-117-00	LABEL, SAFETY PRECAUTIONS	1	
6	68-158-04	HOSE CLAMP, CRIMP 11.5-14.0MM	4	
7	68-159-25	HOSE, 1/4" FUEL- SAE 30R9/CARB	2	(43'), (53')
8	68-171-01	TUBING, 1/4" VACUUM RATED NYLON	2	(47'), (57')
9	68-172-13	ADAPTER, 1/4" PLUG-IN X 1/4" PTC 90	2	
10	68-179-10	SEALED ROCKER SWITCH, 3 POSITION 2 LAMP	1	
11	68-179-11	SELECTOR SWITCH, 3 POSITION	1	
12	68-243-30	ELBOW, 3/4" NPT-M X 3/4" HOSE BARB - NYLON	1	
13	77-064-01	ASSEMBLY, INLET ELBOW	1	
14	77-242-01	ISOLATION MOUNT, 35 LB	5	
15	77-248-00	HARNES, HPU TO BATTERY	1	
16	77-260-03	POWERPACK, KUBOTA D1105 DIESEL - NO CTRL	1	
17	77-267-02	LABEL, HYDRAULIC CONTROLS 3 POSITION	1	
18	77-267-05	LABEL, THROTTLE	1	
19	77-272-10	INDICATOR, GREEN LED JWPF CONNECTOR	1	
20	77-272-20	INDICATOR, RED LED JWPF CONNECTOR	1	
21	77-277-50	PVC EDGE TRIM, 0.090" TO 0.190" EDGE THICKNESS	2	(6'), (7')
22	77-282-15	10 GALLON DIESEL FUEL TANK	1	
23	77-285-03	RESERVOIR ASSEMBLY, 3 CIRCUIT SKIDS	1	
24	77-290-10	WELDMENT, CONTROL MOUNT	1	
25	77-290-14	BATTERY HOLD DOWN BRACKET	2	
26	77-290-19	CONTROL PANEL	1	
27	77-290-40	CLAMPING WASHER	12	
28	77-292-02	32 1/8" HOSE ASSEMBLY, -08 FJ X -08 FJ 90 X -08 HOSE	1	
29	77-292-03	33 1/8" HOSE ASSEMBLY, -16 FJ X -16 FJ 90 X -16 HOSE	1	
30	77-313-50	BATTERY, DEEP CYCLE 12V	1	
31	77-520-03-26	WIRE HARNESS, POWER TO CTL BOX	1	
32	77-520-03-30	WIRE HARNESS, RESERVOIR CONTROLS	1	
33	77-520-03-31	WIRE HARNESS, BATTERY TO ENGINE	1	
34	77-520-03-32	WIRE HARNESS, KUBOTA D1105 DIESEL ENGINE	1	
35	77-520-03-33	WIRE HARNESS, GND TO CTL BOX - DIESEL	1	
36	77-520-10	CONTROL CABINET, VMT DIESEL	1	
37	90-018-50	PLUG, SAE-8 ORB	1	
38	90-051-07	HHCS, 1/4-20 X 3/4 GRADE 5 ZN	2	
39	90-051-10	HHCS, 1/4-20 X 1	8	
40	90-051-22	HHCS, 1/4-20 X 2-1/4	4	
41	90-052-05	BHCS, 1/4-20 X 1/2	4	
42	90-055-01	NUT, 1/4-20 HEX	14	
43	90-055-18	NUT, 1/4-20 ACORN	10	
44	90-055-52	WASHER, 1/4 SPLIT RING	24	
45	90-055-53	WASHER, FLAT, 1/4	18	
46	90-061-05	HHCS, 5/16-18 X 1/2	1	
47	90-065-51	WASHER, 5/16 SPLIT RING	1	
48	90-065-52	WASHER, 5/16 FLAT	1	
49	90-071-10	HHCS, 3/8-16 X 1	6	
50	90-071-20	HHCS, 3/8-16 X 2 GR 5 ZN	5	
51	90-075-01	NUT, 3/8-16 HEX GR 5 ZN	5	
52	90-075-52	WASHER, 3/8 SPLIT RING	11	
53	90-075-53	WASHER, 3/8 FLAT	16	
54	90-088-92	PLUG, SAE -12 ORB (1 1/16-12 THREAD)	1	
55	90-091-15	HHCS, 1/2-13 X 1-1/2 GRADE 8 ZN	12	
56	90-095-52	WASHER, 1/2 FLAT	13	
57	90-095-58	WASHER, 1/2 SPLIT RING	12	
58	90-098-77	-8 (3/4-16) JIC CAP	1	
59	90-218-40	-12 (1 1/16 - 12) JIC CAP	1	
60	90-903-10	CUSHIONED LOOP CLAMP, 1"	5	
61	90-903-50	CUSHIONED LOOP CLAMP, 1/2"	6	
62	90-903-75	CUSHIONED LOOP CLAMP, 3/4"	4	
63	90-1062-58	HHFS, 1/4-20 X 5/8" GR5 ZN	6	
64	90-4921K44	FITTING, DRAIN, 1/4" NPT	1	
65	90-5111K204	BULKHEAD FITTING, 1/4" PTC X 1/4" NPTF	1	
66	90-579K693	FITTING, 1/4" TUBE STEM TEE	1	

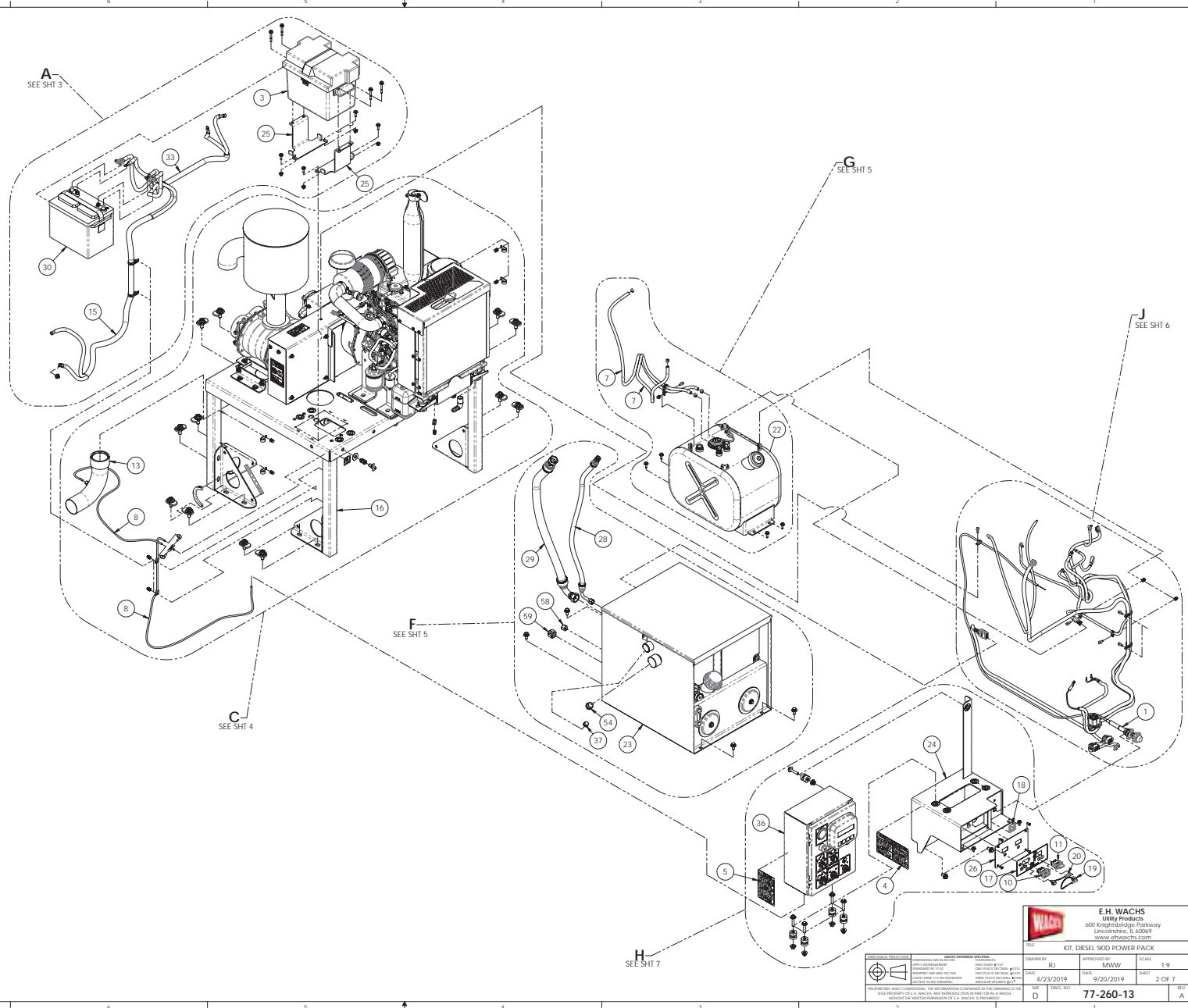

		E.H. WACHS Utility Products 600 Knightbridge Parkway Lincolnshire, IL 60069 www.ehwachs.com	
		KIT, DIESEL SKID POWER PACK	SCALE 1:1
DRAWN BY RJ	APPROVED BY RJM	DATE 4/23/2019	SHEET 2 OF 7
PROPOSED AND CHECKED FOR CONFORMANCE TO THE STANDARD OF THE SOCIETY OF AUTOMOTIVE ENGINEERS (SAE)		REV. 1	77-260-13

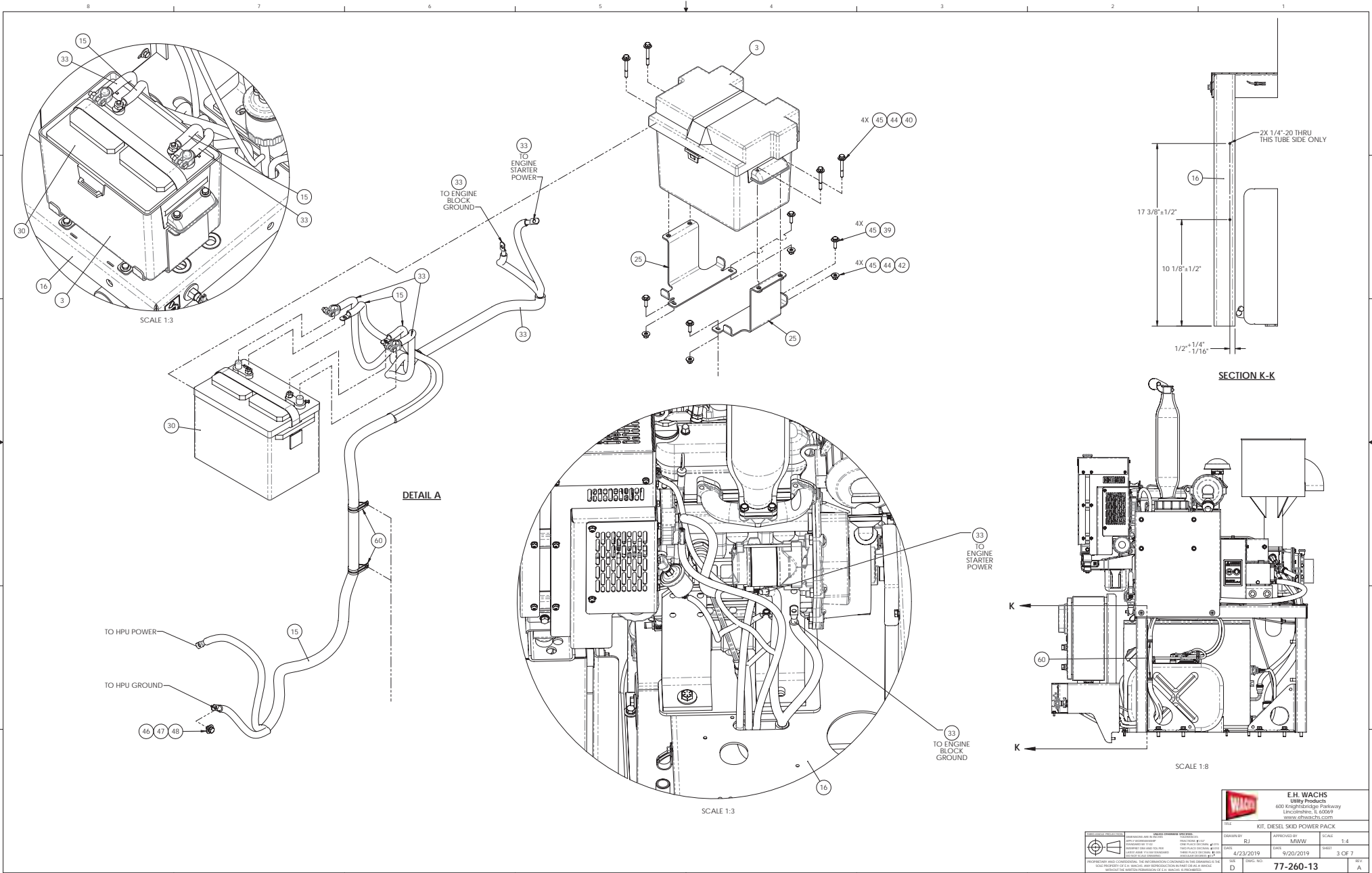

E.H. WACHS
Utility Products
600 Knightbridge Parkway
Lincolnshire, IL 60069
www.ehwachs.com

TITLE		KIT, DIESEL SKID POWER PACK	
DESIGNED BY	REVIEWED BY	DATE	SCALE
RJ	RMW	4/23/2019	1:4
DATE	DATE	DATE	SHEET
9/20/2019	9/20/2019	4/23/2019	3 OF 7
REV	DATE	BY	REV
D			A

77-260-13

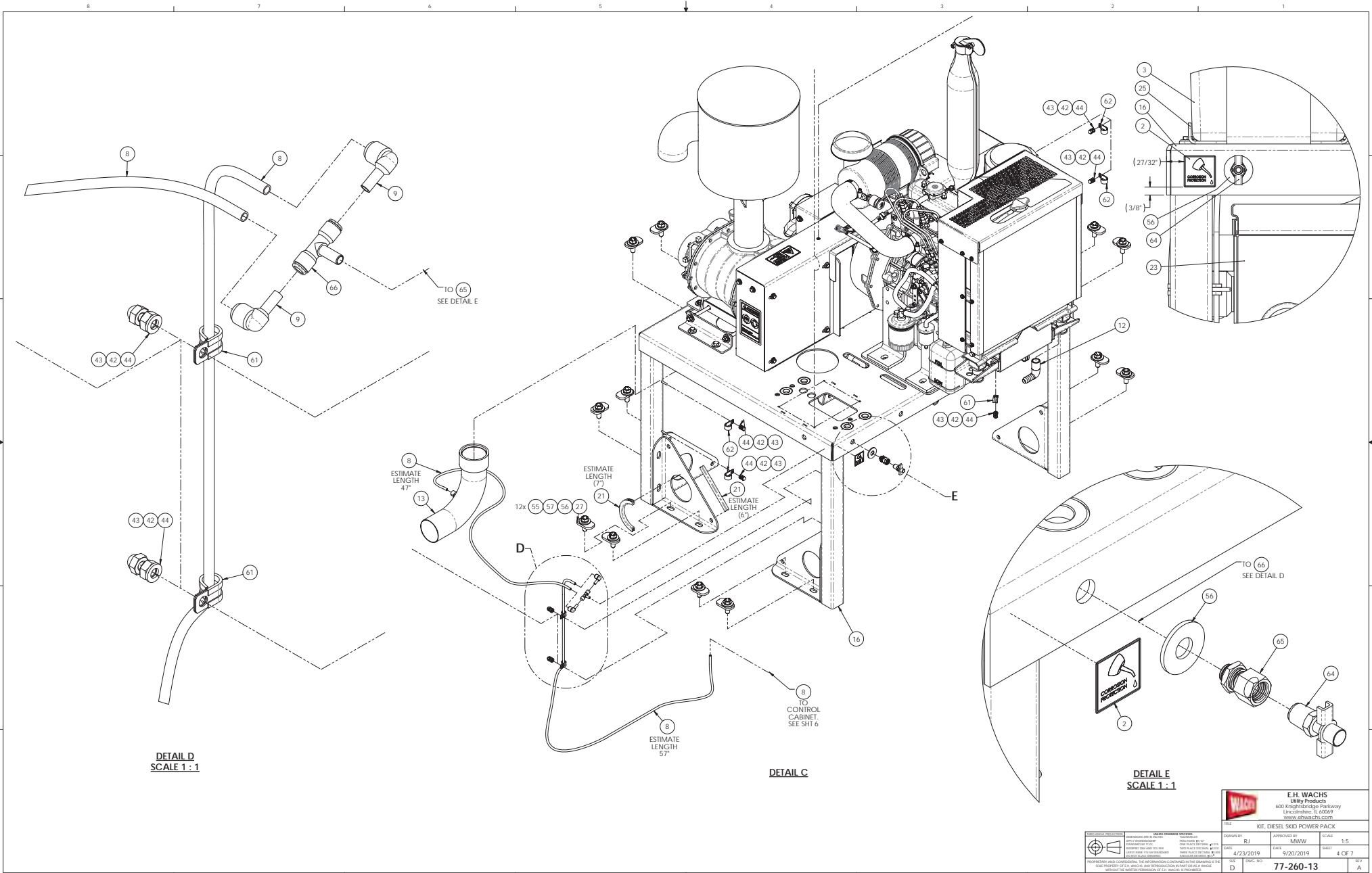

DETAIL D
SCALE 1:1

DETAIL C

DETAIL E
SCALE 1:1

		E. H. WACHS Utility Products 600 Knightbridge Parkway Lincolnshire, IL 60069 www.ehwachs.com	
		KIT, DIESEL SKID POWER PACK	SCALE 1:5
DRAWN BY RJ	APPROVED BY RW	DATE 4/23/2019	SHEET 4 OF 7
TITLE D	REV. NO. 1	77-260-13	

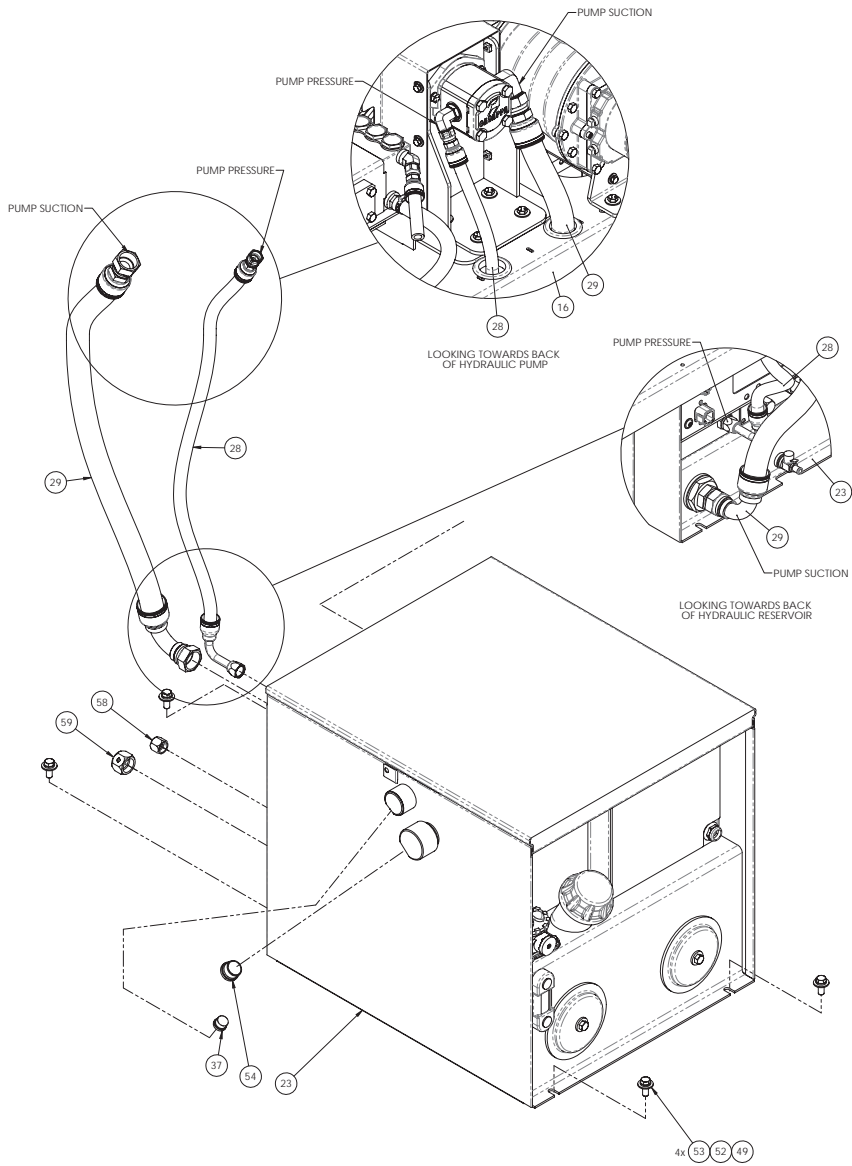

DETAIL F

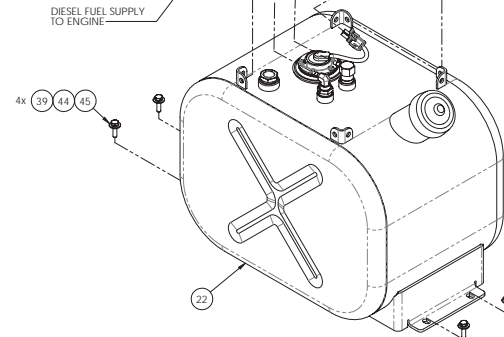
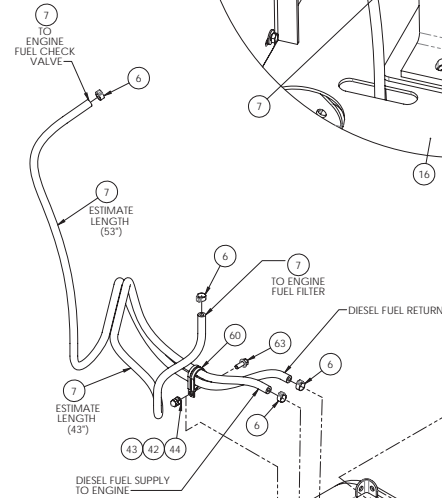
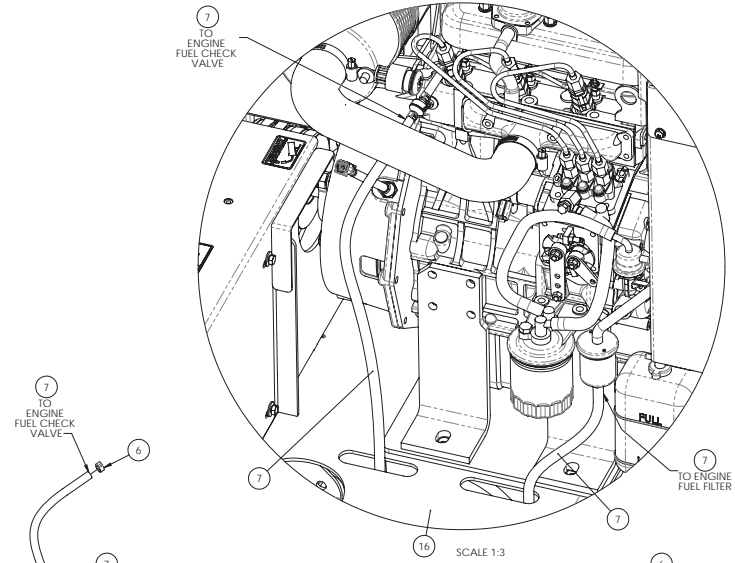

DETAIL G

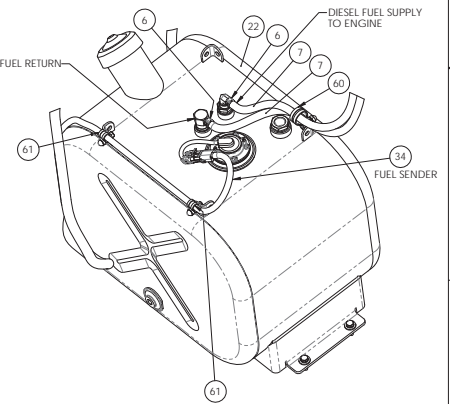

		E.H. WACHS Utility Products 600 Knightbridge Parkway Lincolnshire, IL 60069 www.ehwachs.com	
		KIT, DIESEL SKID POWER PACK	SCALE 1:4
DRAWN BY RJ	APPROVED BY RWV	DATE 4/23/2019	DATE 9/20/2019
SHEET D	TOTAL SHEETS 5	REV. NO. 1	REV. A

77-260-13

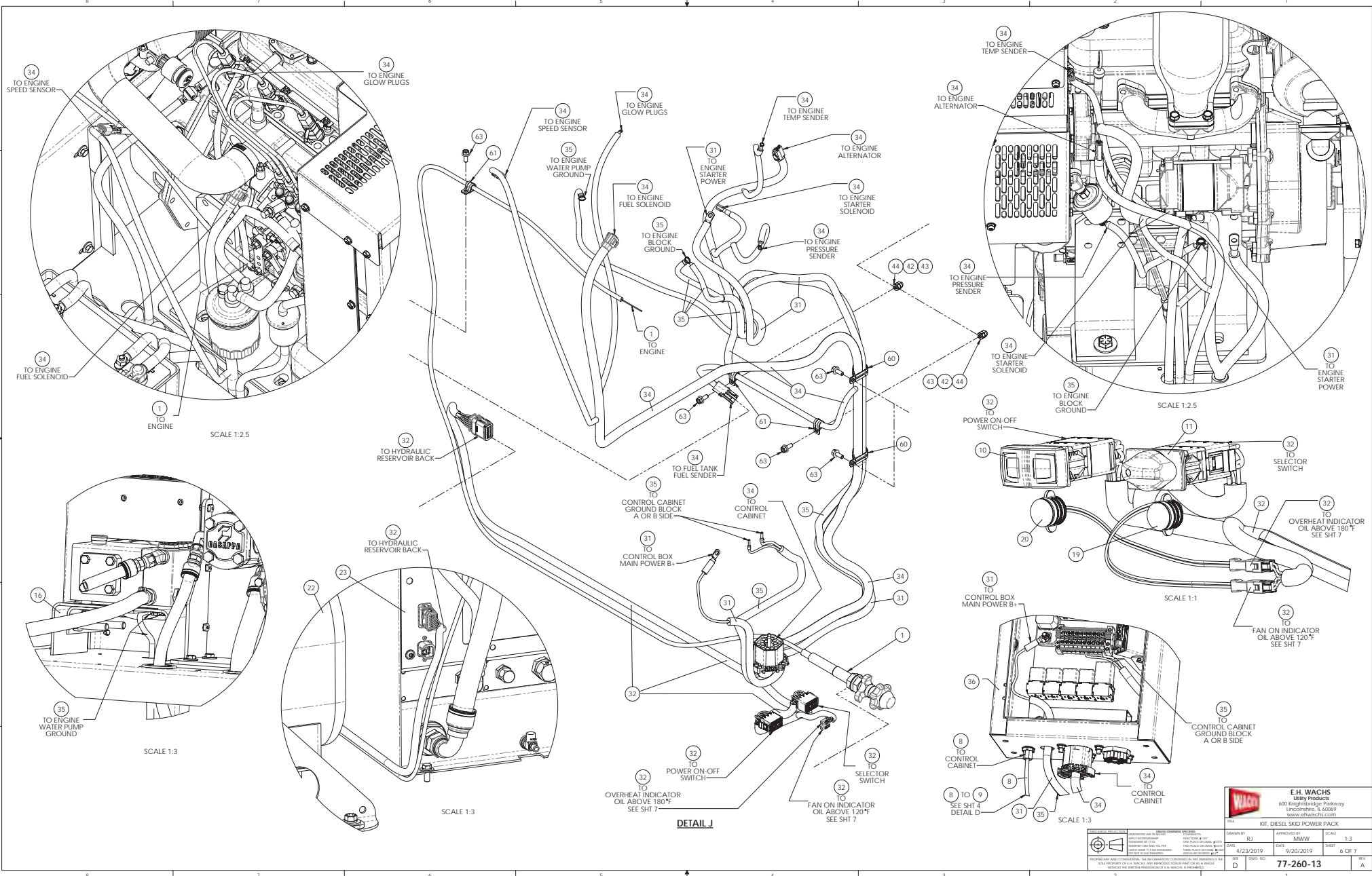

DETAIL J

		E.H. WACHS Utility Products 600 Knightbridge Parkway Lincolnshire, IL 60069 www.ehwachs.com	
KIT, DIESEL SKID POWER PACK			
DRAWN BY: RJ DATE: 4/23/2019 SHEET: 6 OF 7	APPROVED BY: MMW DATE: 9/20/2019 SHEET: 6 OF 7	SCALE: 1:3	REV: A
77-260-13			

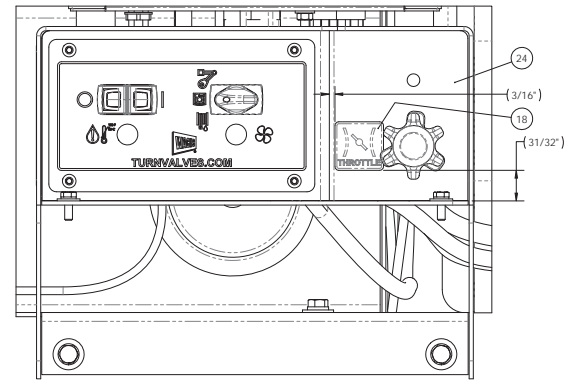
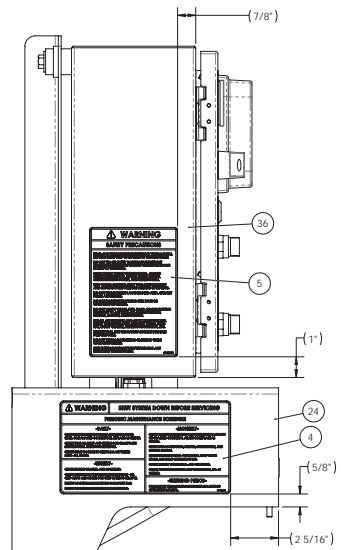

SCALE 1:2

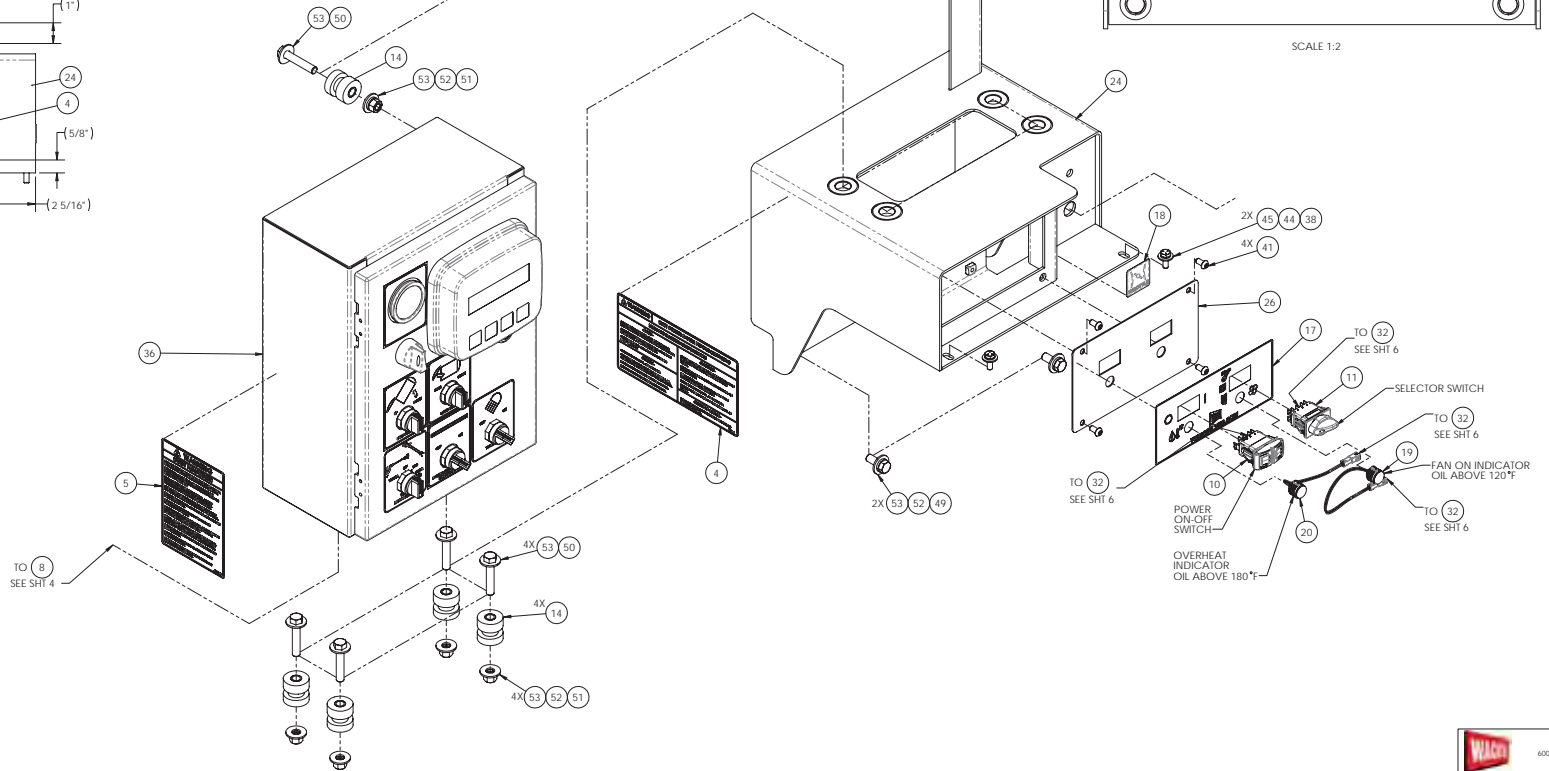

DETAIL H

E.H. WACHS
Utility Products
600 Knightbridge Parkway
Lincolnshire, IL 60069
www.ehwachs.com

		KIT, DIESEL SKID POWER PACK	
DRAWN BY: RJ DATE: 4/23/2019	CHECKED BY: RMW DATE: 9/20/2019	APPROVED BY: [Signature] DATE: 9/20/2019	SCALE: 1:3 SHEET: 7 OF 7
PROJECT: [Blank] SHEET: D	REV: [Blank] DATE: 9/20/2019	PART NO: 77-260-13	REV: A

NOTES:

1. MATERIAL: PER COMPONENT
2. FINISH: PER COMPONENT
3. APPROX. WEIGHT: 833 LBS.
4. NO CONTROL BOX (77-520-10)
5. PRESSURE WASHER PUMP REPLACEMENT PARTS:
CLUTCH: 77-100-00
PUMP: 77-085-00

REVISION HISTORY			
REV	DESCRIPTION	DATE	APR
A	NEW RELEASE PER ECO 3702	10/8/2018	HM

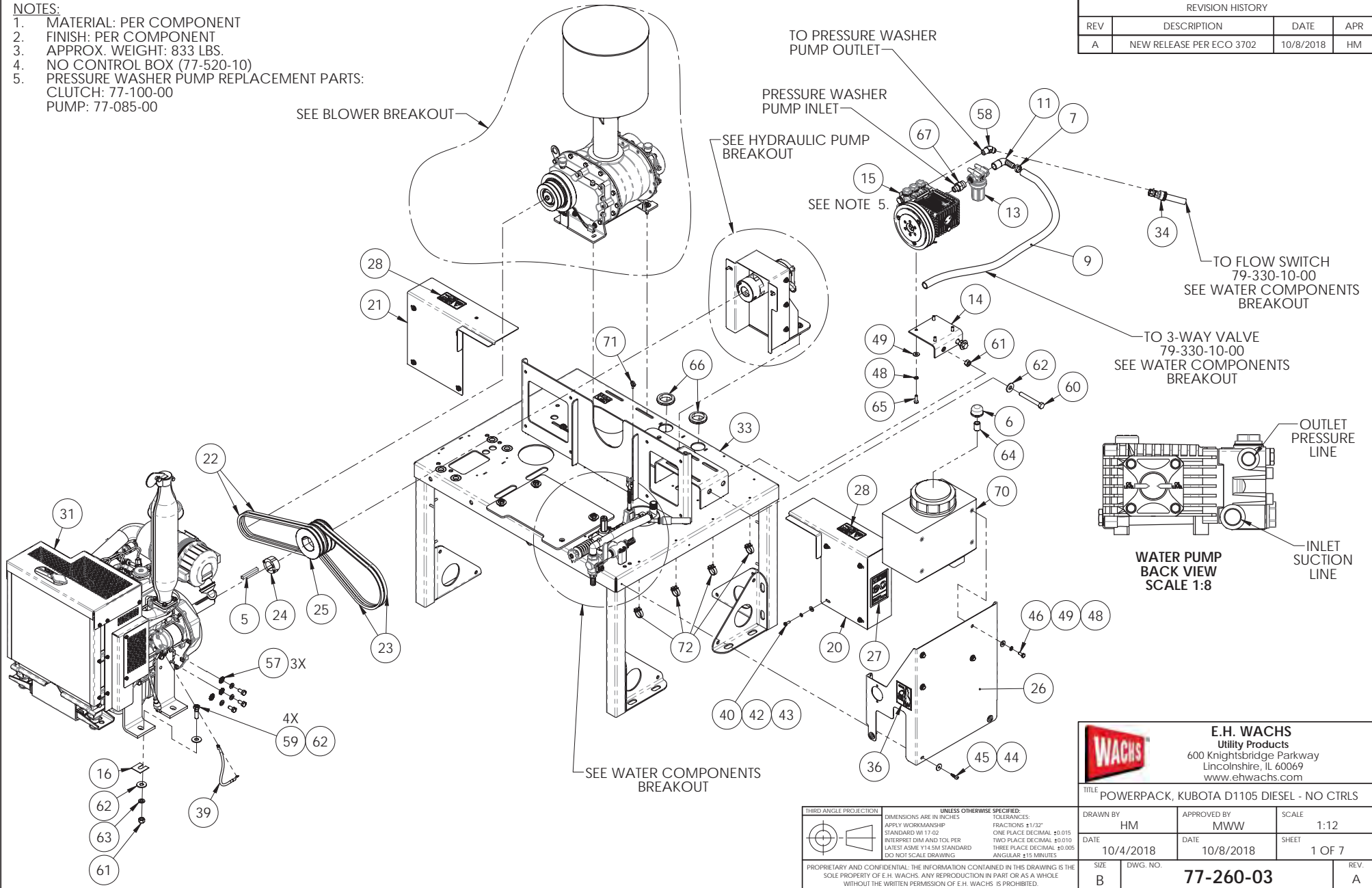

 E.H. WACHS Utility Products 600 Knightsbridge Parkway Lincolnshire, IL 60069 www.ehwachs.com			
			TITLE POWERPACK, KUBOTA D1105 DIESEL - NO CTRLS
DRAWN BY HM	APPROVED BY MWW	SCALE 1:12	
DATE 10/4/2018	DATE 10/8/2018	SHEET 1 OF 7	
SIZE B	DWG. NO. 77-260-03		REV. A

THIRD ANGLE PROJECTION

DIMENSIONS ARE IN INCHES
 APPLY WORKMANSHIP
 STANDARD W/ 17-02
 INTERPRET DIM AND TOL PER
 LATEST ASME Y14.5M STANDARD
 DO NOT SCALE DRAWING

UNLESS OTHERWISE SPECIFIED:
 TOLERANCES:
 FRACTIONS ±1/32"
 ONE PLACE DECIMAL ±0.015
 TWO PLACE DECIMAL ±0.010
 THREE PLACE DECIMAL ±0.005
 ANGULAR ±15 MINUTES

PROPRIETARY AND CONFIDENTIAL: THE INFORMATION CONTAINED IN THIS DRAWING IS THE
 SOLE PROPERTY OF E.H. WACHS. ANY REPRODUCTION IN PART OR AS A WHOLE
 WITHOUT THE WRITTEN PERMISSION OF E.H. WACHS IS PROHIBITED.

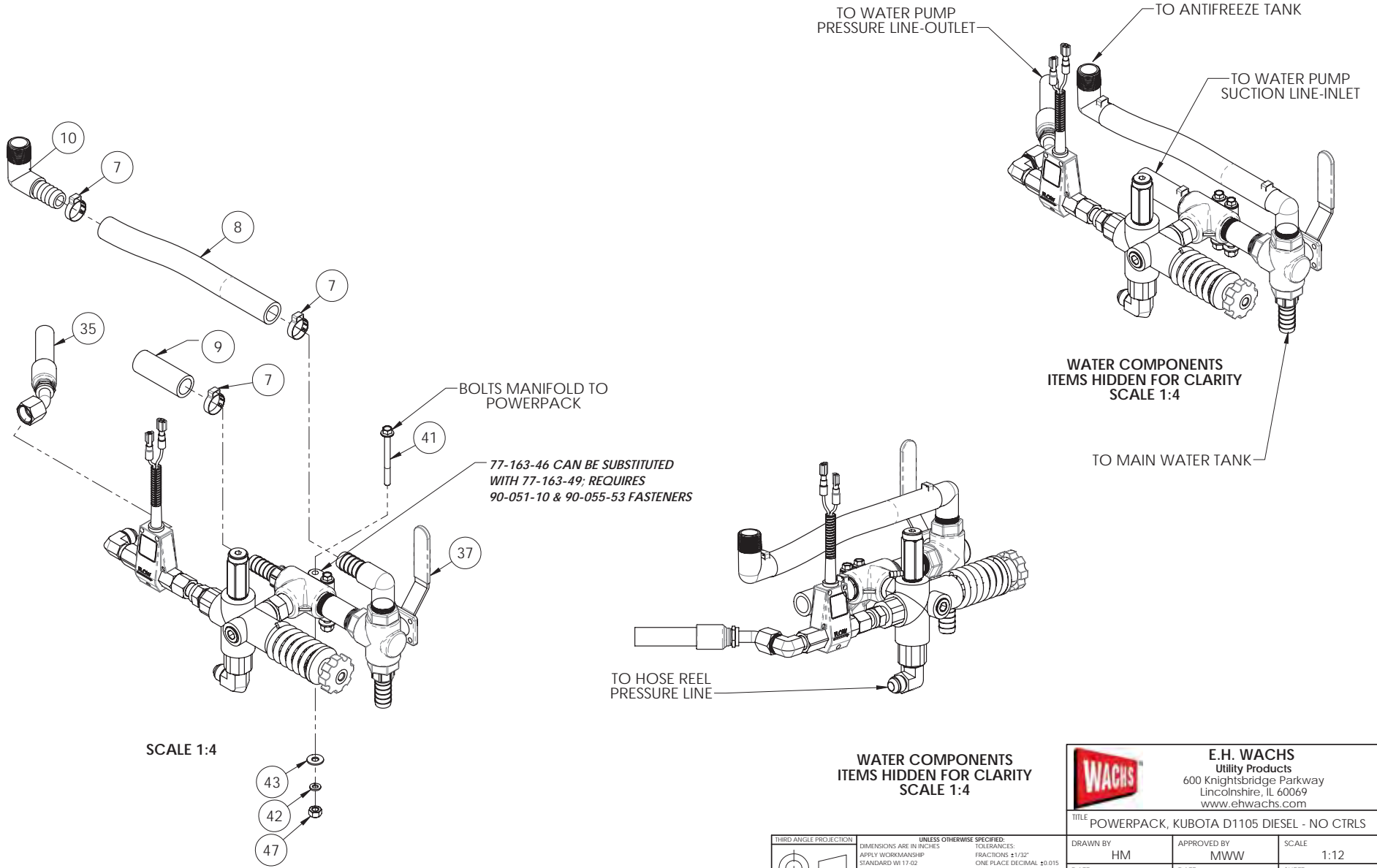

SCALE 1:4

WATER COMPONENTS
ITEMS HIDDEN FOR CLARITY
SCALE 1:4

E.H. WACHS
Utility Products
600 Knightsbridge Parkway
Lincolnshire, IL 60069
www.ehwachs.com

TITLE POWERPACK, KUBOTA D1105 DIESEL - NO CTRLS

	DIMENSIONS ARE IN INCHES APPLY WORKMANSHIP STANDARD W/ 17-02 INTERPRET DIM AND TOL PER LATEST ASME Y14.5M STANDARD DO NOT SCALE DRAWING	UNLESS OTHERWISE SPECIFIED: TOLERANCES: FRACTIONS ±1/32" ONE PLACE DECIMAL ±0.015 TWO PLACE DECIMAL ±0.010 THREE PLACE DECIMAL ±0.005 ANGULAR ±15 MINUTES
	PROPRIETARY AND CONFIDENTIAL: THE INFORMATION CONTAINED IN THIS DRAWING IS THE SOLE PROPERTY OF E.H. WACHS. ANY REPRODUCTION IN PART OR AS A WHOLE WITHOUT THE WRITTEN PERMISSION OF E.H. WACHS IS PROHIBITED.	

DRAWN BY HM	APPROVED BY MWW	SCALE 1:12
DATE 10/4/2018	DATE 10/8/2018	SHEET 2 OF 7

SIZE B	DWG. NO. 77-260-03	REV. A
-----------	------------------------------	-----------

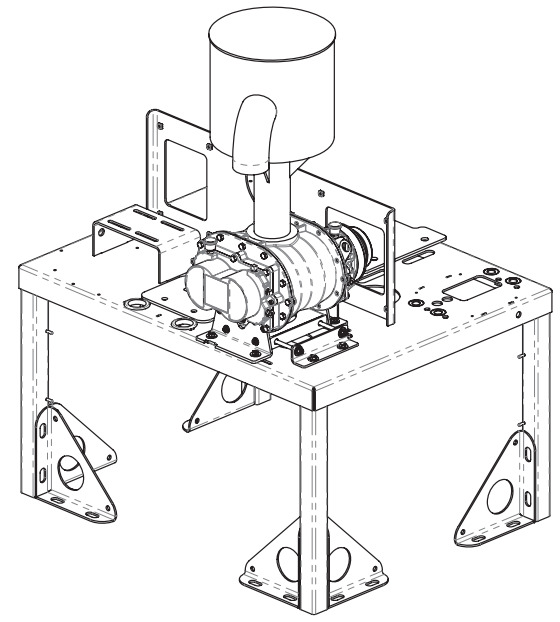
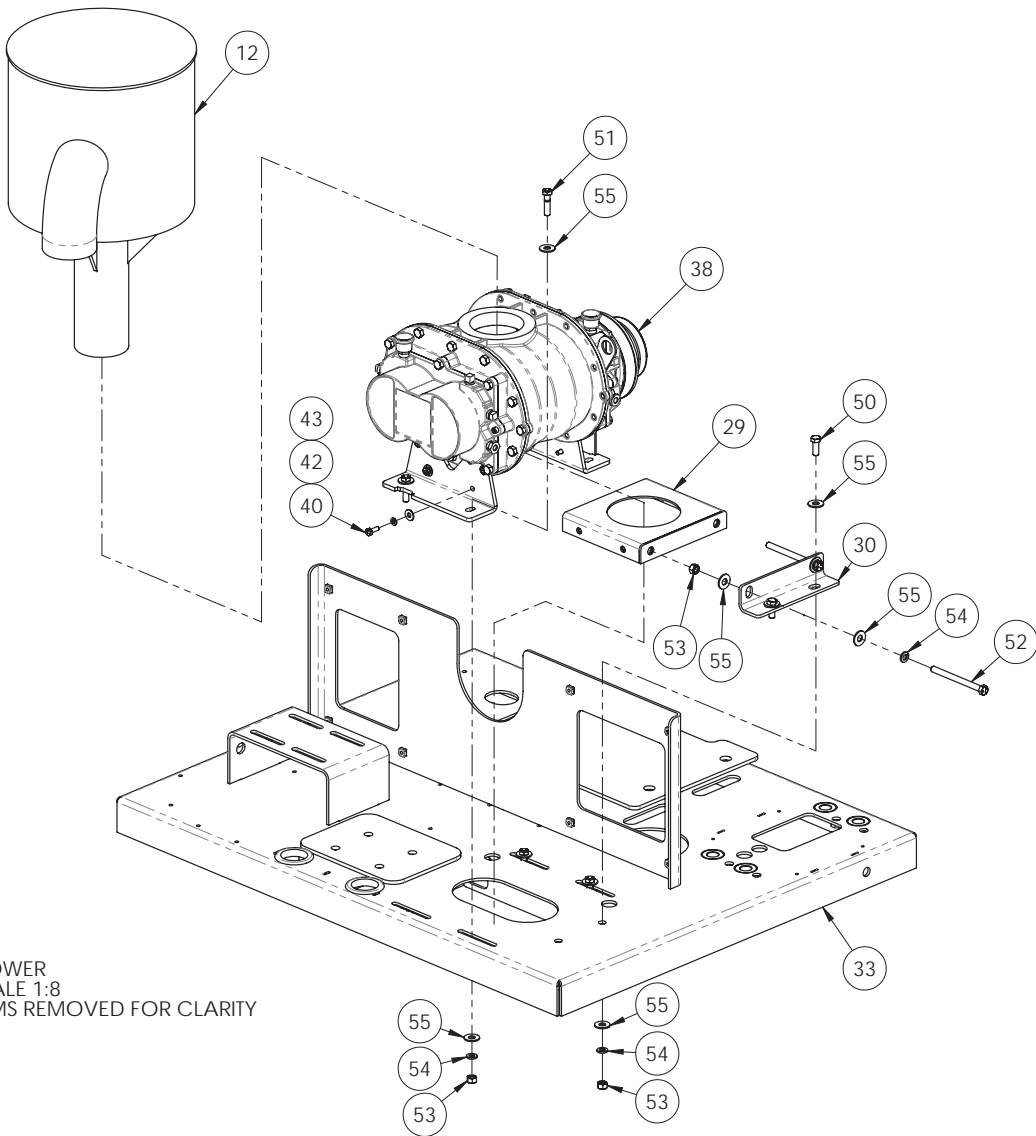

BLOWER
SCALE 1:8
ITEMS REMOVED FOR CLARITY

WACHS
E.H. WACHS
Utility Products
600 Knightsbridge Parkway
Lincolnshire, IL 60069
www.ehwachs.com

TITLE POWERPACK, KUBOTA D1105 DIESEL - NO CTRLS

	<small>UNLESS OTHERWISE SPECIFIED:</small> <small>DIMENSIONS ARE IN INCHES</small> <small>APPLY WORKMANSHIP</small> <small>STANDARD W/ 17-02</small> <small>INTERPRET DIM AND TOL PER</small> <small>LATEST ASME Y14.5M STANDARD</small> <small>DO NOT SCALE DRAWING</small>		<small>TOLERANCES:</small> <small>FRACTIONS ±1/32"</small> <small>ONE PLACE DECIMAL ±0.015</small> <small>TWO PLACE DECIMAL ±0.010</small> <small>THREE PLACE DECIMAL ±0.005</small> <small>ANGULAR ±15 MINUTES</small>	
	<small>THIRD ANGLE PROJECTION</small>	<small>DRAWN BY</small> HM	<small>APPROVED BY</small> MWW	<small>SCALE</small> 1:12
<small>PROPRIETARY AND CONFIDENTIAL: THE INFORMATION CONTAINED IN THIS DRAWING IS THE SOLE PROPERTY OF E.H. WACHS. ANY REPRODUCTION IN PART OR AS A WHOLE WITHOUT THE WRITTEN PERMISSION OF E.H. WACHS IS PROHIBITED.</small>		<small>DATE</small> 10/4/2018	<small>DATE</small> 10/8/2018	<small>SHEET</small> 3 OF 7
<small>SIZE</small> B	<small>DWG. NO.</small> 77-260-03		<small>REV.</small> A	

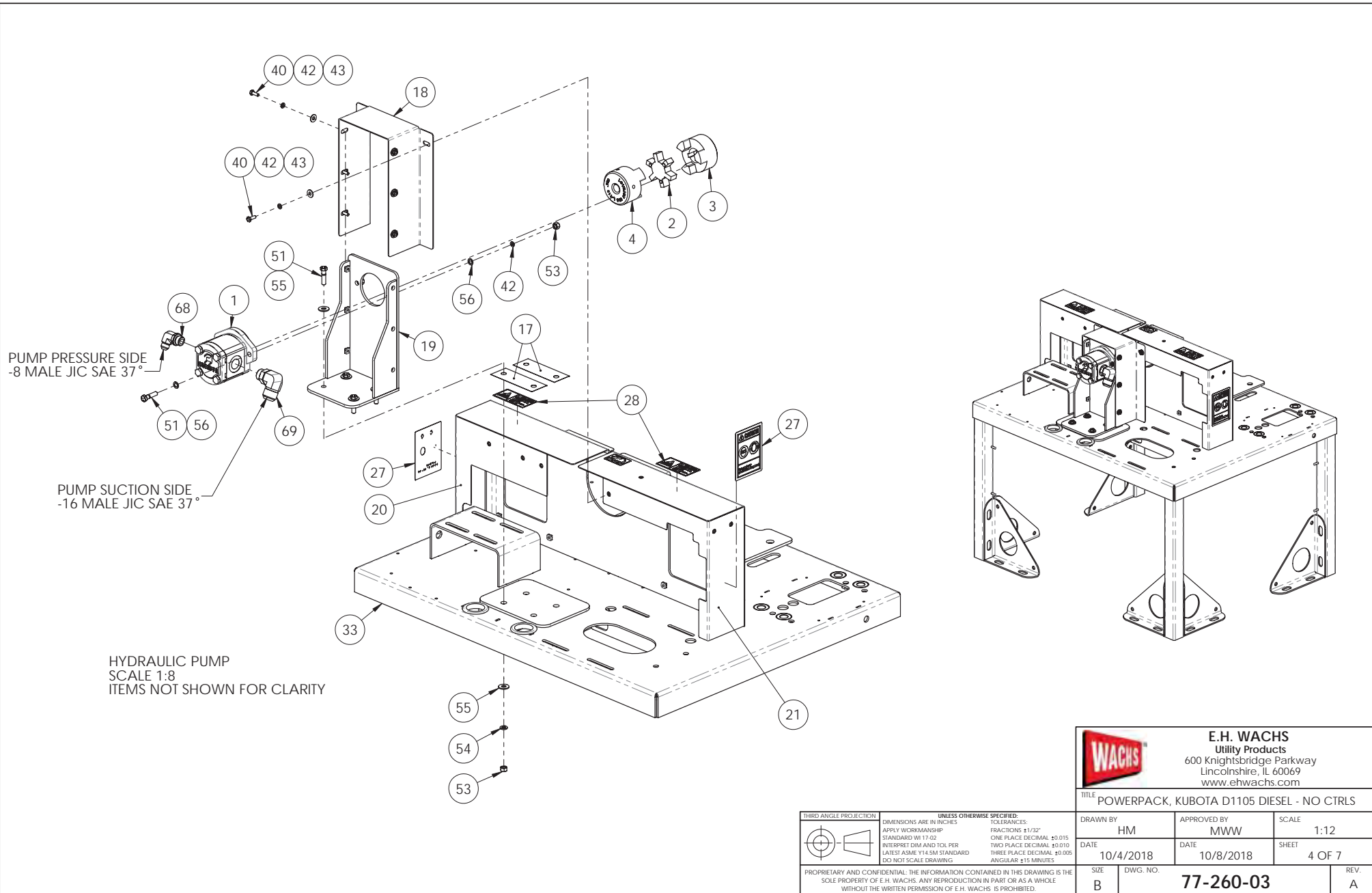

PUMP PRESSURE SIDE
-8 MALE JIC SAE 37°

PUMP SUCTION SIDE
-16 MALE JIC SAE 37°

HYDRAULIC PUMP
SCALE 1:8
ITEMS NOT SHOWN FOR CLARITY

WACHS
E.H. WACHS
 Utility Products
 600 Knightsbridge Parkway
 Lincolnshire, IL 60069
 www.ehwachs.com

TITLE POWERPACK, KUBOTA D1105 DIESEL - NO CTRLS

THIRD ANGLE PROJECTION

DIMENSIONS ARE IN INCHES
 APPLY WORKMANSHIP
 STANDARD W/ 17-02
 INTERPRET DIM AND TOL PER
 LATEST ASME Y14.5M STANDARD
 DO NOT SCALE DRAWING

UNLESS OTHERWISE SPECIFIED:
 TOLERANCES:
 FRACTIONS ±1/32"
 ONE PLACE DECIMAL ±0.015
 TWO PLACE DECIMAL ±0.010
 THREE PLACE DECIMAL ±0.005
 ANGULAR ±15 MINUTES

DRAWN BY HM	APPROVED BY MWW	SCALE 1:12
DATE 10/4/2018	DATE 10/8/2018	SHEET 4 OF 7

PROPRIETARY AND CONFIDENTIAL: THE INFORMATION CONTAINED IN THIS DRAWING IS THE SOLE PROPERTY OF E.H. WACHS. ANY REPRODUCTION IN PART OR AS A WHOLE WITHOUT THE WRITTEN PERMISSION OF E.H. WACHS IS PROHIBITED.

SIZE B	DWG. NO. 77-260-03	REV. A
-----------	-----------------------	-----------

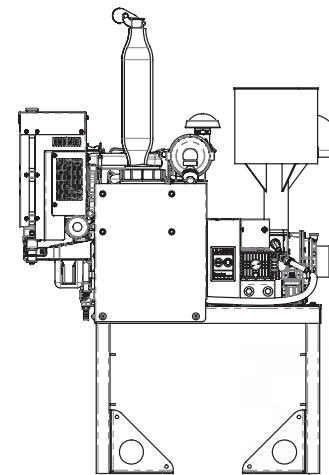
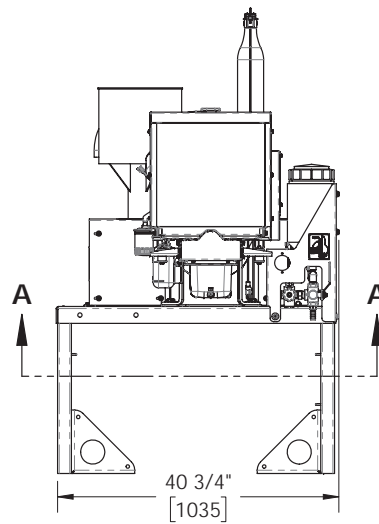
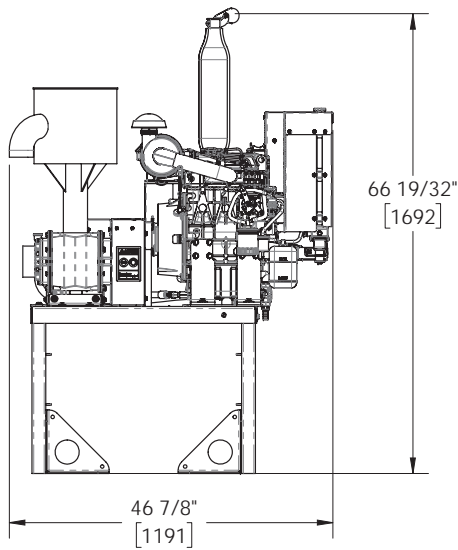

MOUNTING HOLES
12X 9/16" [14] X 1" [25] THRU

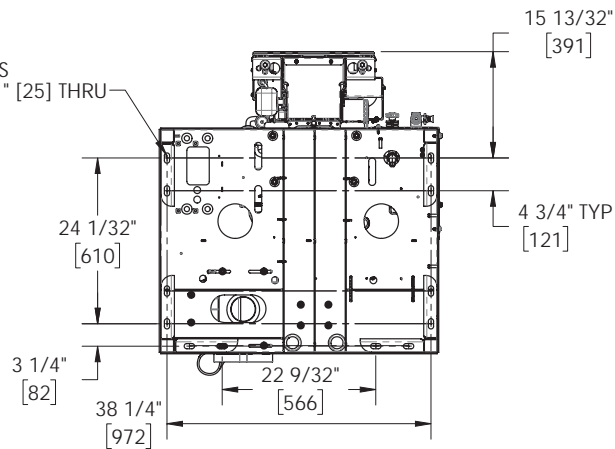
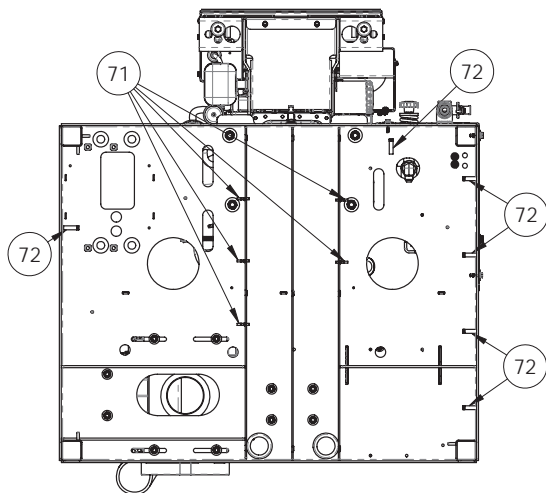

SECTION A-A
SCALE 1 : 12

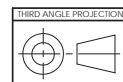

THIRD ANGLE PROJECTION

DIMENSIONS ARE IN INCHES
APPLY WORKMANSHIP
STANDARD W/ 17-02
INTERPRET DIM AND TOL PER
LATEST ASME Y14.5M STANDARD
DO NOT SCALE DRAWING

UNLESS OTHERWISE SPECIFIED:
TOLERANCES:
FRACTIONS ±1/32"
ONE PLACE DECIMAL ±0.015
TWO PLACE DECIMAL ±0.010
THREE PLACE DECIMAL ±0.005
ANGULAR ±15 MINUTES

PROPRIETARY AND CONFIDENTIAL: THE INFORMATION CONTAINED IN THIS DRAWING IS THE SOLE PROPERTY OF E.H. WACHS. ANY REPRODUCTION IN PART OR AS A WHOLE WITHOUT THE WRITTEN PERMISSION OF E.H. WACHS IS PROHIBITED.

		E.H. WACHS Utility Products 600 Knightsbridge Parkway Lincolnshire, IL 60069 www.ehwachs.com	
TITLE POWERPACK, KUBOTA D1105 DIESEL - NO CTRLS			
DRAWN BY HM	APPROVED BY MWW	SCALE 1:18	
DATE 10/4/2018	DATE 10/8/2018	SHEET 5 OF 7	
SIZE B	DWG. NO. 77-260-03	REV. A	

ITEM NO.	PART NUMBER	QTY	DESCRIPTION	LENGTH
1	17-060-01	1	PUMP, HYDRAULIC GEAR	
2	17-061-30	1	SPIDER, L110 HYTREL - CLOSED CENTER	
3	17-061-40	1	HUB, AL110 1-7/16" BORE (3/16" X 3/8" KEY)	
4	17-061-50	1	HUB, AL110 3/4" BORE (3/32" X 3/16" KEY)	
5	67-294-00	1	KEYSTOCK, 3/8" X 3/8" (INCH)	3"
6	68-138-02	1	Strainer, Antifreeze Tank	
7	68-158-16	4	HOSE CLAMP, CRIMP-23.9 - 27.1 MM	
8	68-233-00	1	HOSE, 3/4" LP LOCK ON	10"
9	68-233-00	1	HOSE, 3/4" LP LOCK ON	38"
10	68-243-30	1	ELBOW, 3/4" NPT-M X 3/4" HOSE BARB - NYLON	
11	68-243-30	1	ELBOW, 3/4" NPT-M X 3/4" HOSE BARB - NYLON	
12	77-014-01	1	SILENCER	
13	77-068-25	1	STRAINER	
14	77-082-02	1	WELDMENT, PRESSURE WASHER TENSION	
15	77-085-10	1	PUMP & CLUTCH ASSEMBLY, PRESSURE WASHER	
16	77-087-27	2	ENGINE SHIM KIT	
17	77-087-28	2	PUMP MOUNT SHIM KIT	
18	77-087-35	1	COUPLING GUARD	
19	77-087-36	1	WELDMENT, PUMP MOUNT	
20	77-088-21	1	WELDMENT, PRESSURE WASHER GUARD	
21	77-089-21	1	WELDMENT, BLOWER BELT GUARD	
22	77-111-50	2	V-BELT, AX 37	
23	77-111-50	2	V-BELT, AX 37	
24	77-112-00	1	BUSHING, 1610 X 1-7/16"	
25	77-126-01	1	SHEAVE, 4AB 44 TB 1610	
26	77-151-01-06	1	PANEL, ANTIFREEZE SUPPORT	
27	77-160-05	2	LABEL, EYE AND EAR PROTECTION	
28	77-160-13	2	LABEL, MOVING PARTS PRESENT	
29	77-228-01	1	WELDMENT, BLOWER TENSION	
30	77-229-01	1	ANGLE BRACKET	

ITEM NO.	PART NUMBER	QTY	DESCRIPTION	LENGTH
31	77-240-05	1	ENGINE ASSEMBLY, KUBOTA D1105	
32	77-240-24	1	LABEL, GREASE FITTING	
33	77-253-00	1	WELDMENT, DIESEL POWERPACK	
34	77-330-01-01	1	HOSE ASSEMBLY	
35	77-330-01-01	1	HOSE ASSEMBLY	
36	77-330-03-01	1	LABEL, TANK SELECT VALVE	
37	77-330-10-00	1	ASSEMBLY, WATER CONTROLS POWERPACK VMT-2	
38	77-486-00	1	BLOWER ASSEMBLY	
39	77-520-03-25	1	WIRE HARNESS, ALT TO STARTER	
40	90-051-07	20	HHCS, 1/4-20 X 3/4 GRADE 5 Zn	
41	90-051-27	2	HHCS, 1/4-20 X 2-3/4 SERRATED GRADE 5	
42	90-055-52	24	WASHER, 1/4 SPLIT RING	
43	90-055-53	22	WASHER, FLAT, 1/4	
44	90-055-57	3	WASHER, 1/4 x 1 OD FENDER 18-8SS	
45	90-059-03	3	HHSD, 1/4 X 1 #3PT SS	
46	90-061-07	4	HHCS, 5/16-18 x 3/4	
47	90-065-01	2	NUT, 5/16-18 HEX GRADE 8	
48	90-065-51	8	WASHER, 5/16 SPLIT RING	
49	90-065-52	8	WASHER, 5/16 FLAT	
50	90-071-10	2	HHCS, 3/8-16 X 1	
51	90-071-14	10	HHCS, 3/8-16 X 1-1/2 GR5 ZN	
52	90-071-45	2	HHCS, 3/8-16 X 4-1/2 FLT GR5 ZN	
53	90-075-01	14	NUT, 3/8-16 HEX GR 5 ZN	
54	90-075-52	12	WASHER, 3/8 SPLIT RING	
55	90-075-53	24	WASHER, 3/8 FLAT	
56	90-075-54	4	WASHER, 3/8 AN	
57	90-075-62	3	WASHER, 3/8 INTERNAL/EXTERNAL TOOTH LOCK	
58	90-078-60	1	ADAPTER, 3/8 NPT-M X -8 JIC-M - 45 DEG	
59	90-091-18	4	HHCS, 1/2-13 X 1-3/4 GR8 ZN	
60	90-091-41	2	HHCS, 1/2-13 X 4 FULL TRD GRADE 8	

 E.H. WACHS Utility Products 600 Knightsbridge Parkway Lincolnshire, IL 60069 www.ehwachs.com		
TITLE POWERPACK, KUBOTA D1105 DIESEL - NO CTRLS		
DRAWN BY HM	APPROVED BY MWW	SCALE 1:18
DATE 10/4/2018	DATE 10/8/2018	SHEET 6 OF 7
SIZE B	DWG. NO. 77-260-03	
REV. A		

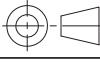
THIRD ANGLE PROJECTION 	UNLESS OTHERWISE SPECIFIED: DIMENSIONS ARE IN INCHES APPLY WORKMANSHIP STANDARD W/ 17-02 INTERPRET DIM AND TOL PER LATEST ASME Y14.5M STANDARD DO NOT SCALE DRAWING	TOLERANCES: FRACTIONS ±1/32" ONE PLACE DECIMAL ±0.015 TWO PLACE DECIMAL ±0.010 THREE PLACE DECIMAL ±0.005 ANGULAR ±15 MINUTES
PROPRIETARY AND CONFIDENTIAL: THE INFORMATION CONTAINED IN THIS DRAWING IS THE SOLE PROPERTY OF E.H. WACHS. ANY REPRODUCTION IN PART OR AS A WHOLE WITHOUT THE WRITTEN PERMISSION OF E.H. WACHS IS PROHIBITED.		

ITEM NO.	PART NUMBER	QTY	DESCRIPTION	LENGTH
61	90-095-01	6	NUT, 1/2"-13 HEX GRADE 8	
62	90-095-52	10	WASHER, 1/2 FLAT	
63	90-095-58	4	WASHER, 1/2 SPLIT RING	
64	90-098-14	1	Nipple, 1/2" Close, PVC,	
65	90-108-25	4	HHCS, M8-1.25 X 25MM DIN 933 GR8.8 ZN	
66	90-135-03	2	GROMMET, 1 3/4" ID X 2" HOLE X 1/4" THK	
67	910-3/4-1/2-FF-S	1	ADAPTER, 3/4" NPT-M X 1/2" NPT-M	
68	910-8-10-C5OX-S	1	ELBOW, -8 M JIC (3/4"-16) X -10 M ORB (7/8"-14)	
69	910-16-12-C5OX-S	1	ADAPTER, -12 MORB X -16 MJIC 90 DEGREE ELBOW	
70	921-SP0003-RT	1	TANK, 3 GALLON	
71	931-561CB025	6	CLIP, PLASTIC LOOM TO FRAME 1/2"	
72	931-561CB100	6	CLIP, PLASTIC LOOM TO FRAME 1"	

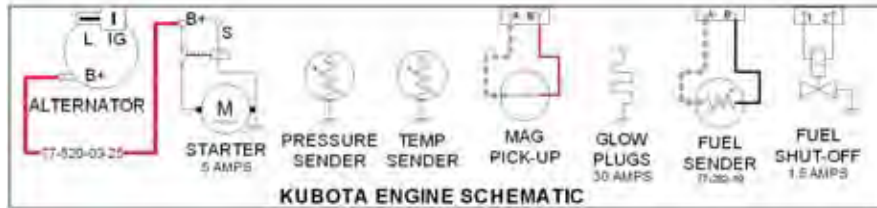

 E.H. WACHS Utility Products 600 Knightsbridge Parkway Lincolnshire, IL 60069 www.ehwachs.com		
TITLE POWERPACK, KUBOTA D1105 DIESEL - NO CTRLS		
DRAWN BY HM	APPROVED BY MWW	SCALE 1:18
DATE 10/4/2018	DATE 10/8/2018	SHEET 7 OF 7
SIZE B	DWG. NO. 77-260-03	
		REV. A

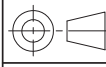
	<small>THIRD ANGLE PROJECTION</small>
	<small>UNLESS OTHERWISE SPECIFIED: DIMENSIONS ARE IN INCHES APPLY WORKMANSHIP STANDARD W/ 17-02 INTERPRET DIM AND TOL PER LATEST ASME Y14.5M STANDARD DO NOT SCALE DRAWING</small>
<small>TOLERANCES: FRACTIONS ±1/32" ONE PLACE DECIMAL ±0.015 TWO PLACE DECIMAL ±0.010 THREE PLACE DECIMAL ±0.005 ANGULAR ±15 MINUTES</small>	<small>PROPRIETARY AND CONFIDENTIAL: THE INFORMATION CONTAINED IN THIS DRAWING IS THE SOLE PROPERTY OF E.H. WACHS. ANY REPRODUCTION IN PART OR AS A WHOLE WITHOUT THE WRITTEN PERMISSION OF E.H. WACHS IS PROHIBITED.</small>

NOTES:

1. MATERIAL - PER COMPONENT
2. FINISH - PER COMPONENT
3. KIT REQUIRES OTHER COMPONENTS / SYSTEMS TO FUNCTION
4. IF STORING OR TRANSPORTING, PACKAGE AND SECURE LOOSE COMPONENTS AND HARDWARE
5. SEE HIGHER LEVEL ASSEMBLY FOR SCHEMATICS AND INTERFACES
6. APPROX WEIGHT: 971.9 LB

REVISION HISTORY			
REV.	DESCRIPTION	DATE	APP.
A	NEW RELEASE, ECO 3784	9/20/2019	MMW

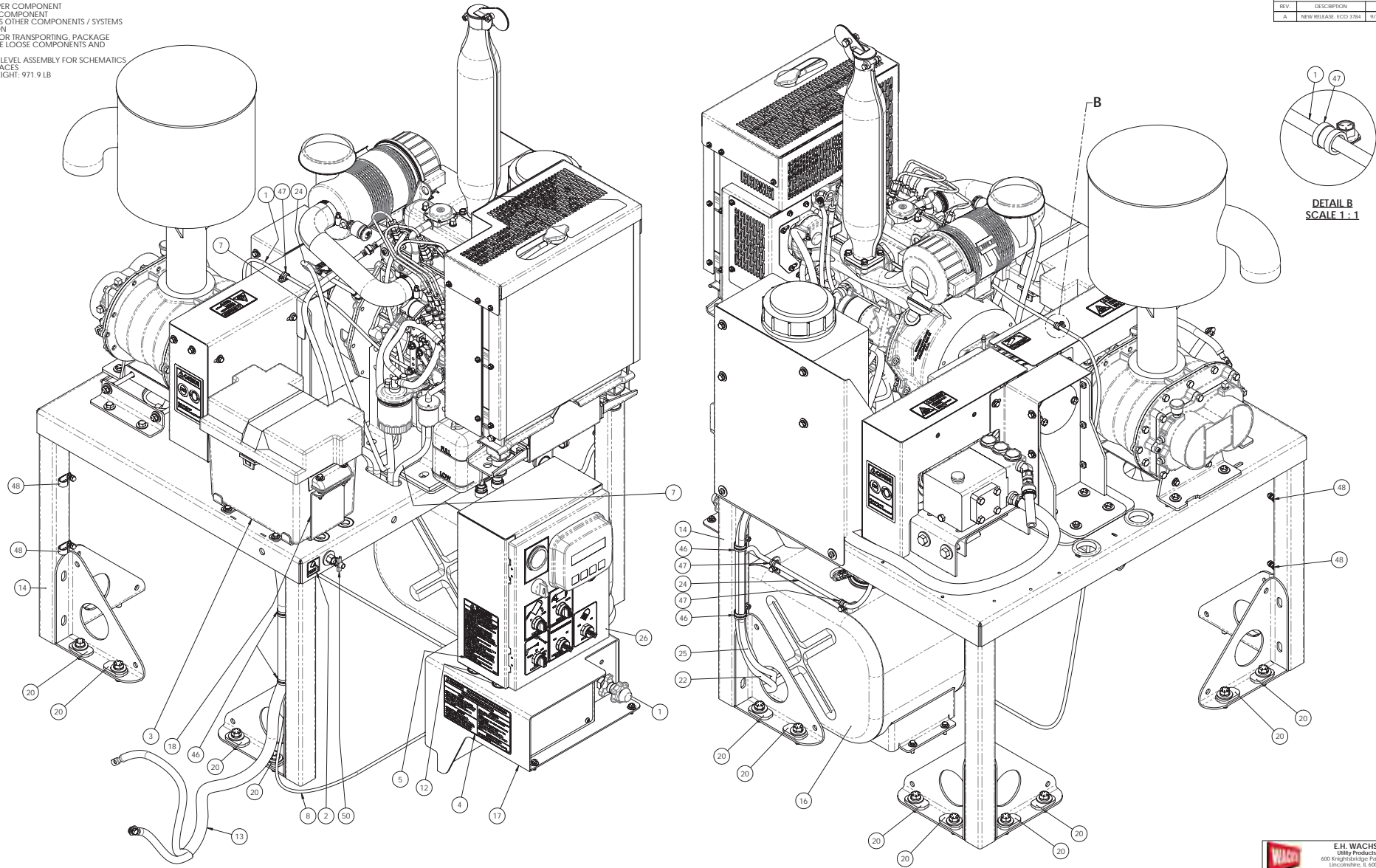

E.H. WACHS
 Utility Products
 600 Knightbridge Parkway
 Lincolnshire, IL 60069
 www.ehwachs.com

KIT, DIESEL SKID POWER PACK - NO HYDRAULICS			
CONTRACT NO.	APPROVED BY	SCALE	REV.
RJ	MMW	1:4	1 OF 7
DATE: 4/23/2019	DATE: 9/20/2019		
ISS: D	TYPE: 3D		

77-260-12

ITEM NO.	PART NUMBER	DESCRIPTION	QTY.	ESTIMATE LENGTH
1	17-065-01	THROTTLE CABLE X 10'	1	
2	59-131-00	LABEL, CORROSION PROTECTION	1	
3	67-051-00	CASE, BATTERY	1	
4	67-112-00	LABEL, MAINTENANCE SCHEDULE	1	
5	67-117-00	LABEL, SAFETY PRECAUTIONS	1	
6	68-158-04	HOSE CLAMP, CRIMP 11.5-14.0MM	4	
7	68-159-25	HOSE, 1/4" FUEL- SAE 30R9/CARB	2	(43"), (53")
8	68-171-01	TUBING, 1/4" VACUUM RATED NYLON	2	(47"), (57")
9	68-172-13	ADAPTER, 1/4" PLUG-IN X 1/4" PTC 90	2	
10	68-243-30	ELBOW, 3/4" NPT-M X 3/4" HOSE BARB- NYLON	1	
11	77-064-01	ASSEMBLY, INLET ELBOW	1	
12	77-242-01	ISOLATION MOUNT, 35 LB	5	
13	77-248-00	HARNESS, HPU TO BATTERY	1	
14	77-260-02	POWERPACK, KUBOTA D1105 DIESEL - NO HYD/CIRLS	1	
15	77-267-05	LABEL, THROTTLE	1	
16	77-282-15	10 GALLON DIESEL FUEL TANK	1	
17	77-290-10	WELDMENT, CONTROL MOUNT	1	
18	77-290-14	BATTERY HOLD DOWN BRACKET	2	
19	77-290-39	CONTROL PANEL PLATE	1	
20	77-290-40	CLAMPING WASHER	12	
21	77-313-50	BATTERY, DEEP CYCLE 12V	1	
22	77-520-03-26	WIRE HARNESS, POWER TO CTL BOX	1	
23	77-520-03-31	WIRE HARNESS, BATTERY TO ENGINE	1	
24	77-520-03-32	WIRE HARNESS, KUBOTA D1105 DIESEL ENGINE	1	
25	77-520-03-33	WIRE HARNESS, GND TO CTL BOX - DIESEL	1	
26	77-520-10	CONTROL CABINET, VMT DIESEL	1	
27	90-051-07	HHCS, 1/4-20 X 3/4 GRADE 5 ZN	2	
28	90-051-10	HHCS, 1/4-20 X 1	8	
29	90-051-22	HHCS, 1/4-20 X 2-1/4	4	
30	90-052-05	BHCS, 1/4-20 X 1/2	4	
31	90-055-01	NUT, 1/4-20 HEX	14	
32	90-055-18	NUT, 1/4-20 ACORN	10	
33	90-055-52	WASHER, 1/4 SPLIT RING	24	
34	90-055-53	WASHER, FLAT, 1/4	18	
35	90-061-05	HHCS, 5/16-18 x 1/2	1	
36	90-065-51	WASHER, 5/16 SPLIT RING	1	
37	90-065-52	WASHER, 5/16 FLAT	1	
38	90-071-10	HHCS, 3/8-16 X 1	2	
39	90-071-20	HHCS, 3/8-16 X 2 GR 5 ZN	5	
40	90-075-01	NUT, 3/8-16 HEX GR 5 ZN	5	
41	90-075-52	WASHER, 3/8 SPLIT RING	7	
42	90-075-53	WASHER, 3/8 FLAT	12	
43	90-091-15	HHCS, 1/2-13 X 1-1/2 GRADE 8 ZN	12	
44	90-095-52	WASHER, 1/2 FLAT	13	
45	90-095-58	WASHER, 1/2 SPLIT RING	12	
46	90-903-10	CUSHIONED LOOP CLAMP, 1"	6	
47	90-903-50	CUSHIONED LOOP CLAMP, 1/2"	6	
48	90-903-75	CUSHIONED LOOP CLAMP, 3/4"	4	
49	90-1062-58	HHFS, 1/4-20 x 5/8" GR5 ZN	6	
50	90-4921K44	FITTING, DRAIN, 1/4" NPT	1	
51	90-5111K204	BULKHEAD FITTING, 1/4" PTC X 1/4" NPTF	1	
52	90-5779K693	FITTING, 1/4" TUBE STEM TEE	1	

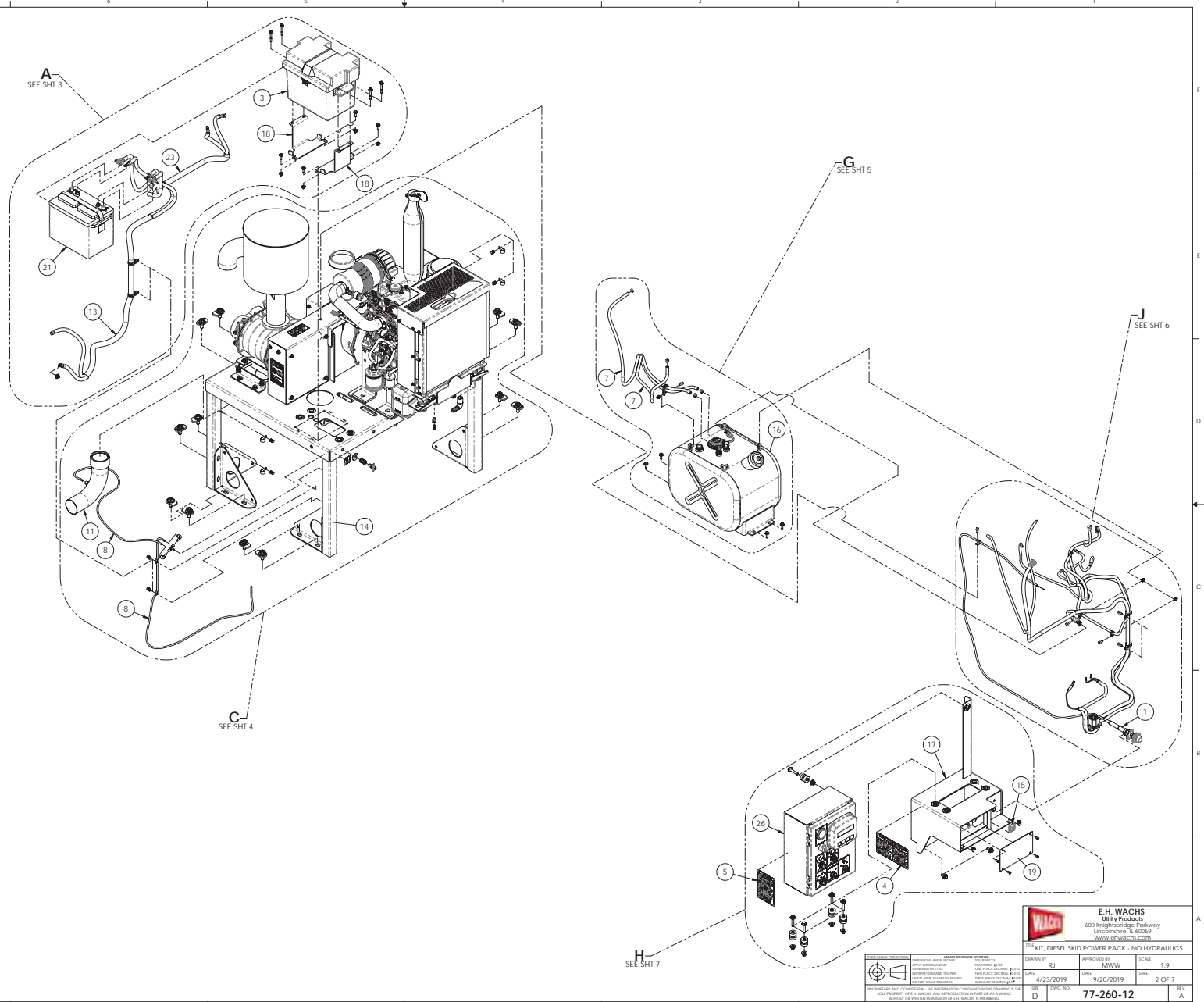

E.H. WACHS
Utility Products
600 Knightbridge Parkway
Lincolnshire, IL 60069
www.ehwachs.com

KIT, DIESEL SKID POWER PACK - NO HYDRAULICS

DESIGNED BY	REVISIONS	DATE	APPROVED BY	SCALE
RJ	1	4/23/2019	BMW	1:1
DATE	REV	DATE	BY	REASON
4/23/2019	1	9/20/2019		
REV	DATE	BY	REASON	
D				

77-260-12

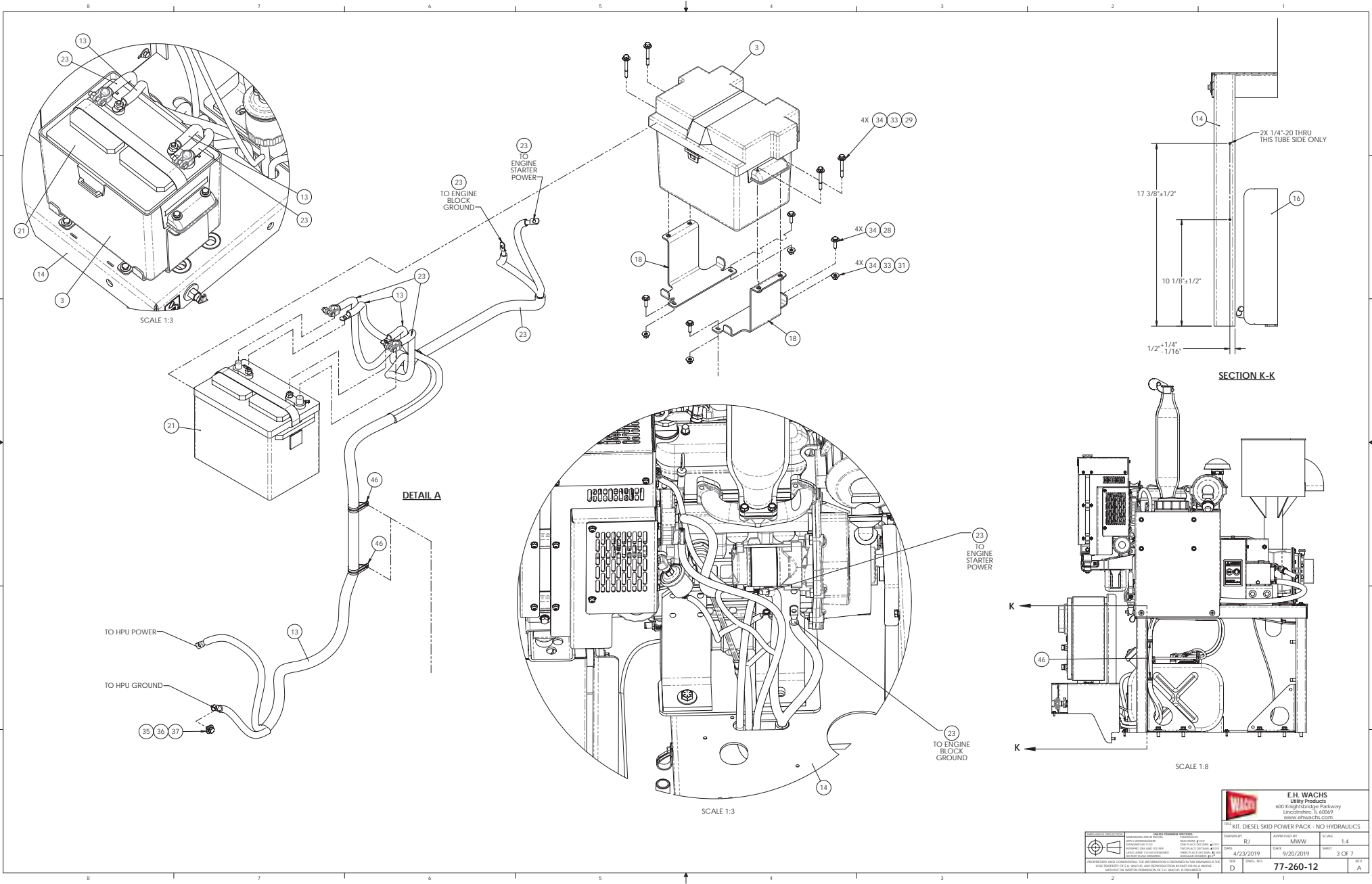

E.H. WACHS
 Utility Products
 600 Knightbridge Parkway
 Lincolnshire, IL 60069
 www.ehwachs.com

		KIT, DIESEL SKID POWER PACK - NO HYDRAULICS	
DRAWN BY RJI	CHECKED BY RJI	APPROVED BY RMW	SCALE 1:4
DATE 4/23/2019	DATE 9/20/2019	SHEET 3 OF 7	REV. A
PROPERTIES AND CHARACTERISTICS: THIS INFORMATION CONTAINS THE TRADE SECRETS AND PROPRIETARY INFORMATION OF E.H. WACHS & COMPANY. IT IS TO BE KEPT CONFIDENTIAL AND NOT TO BE DISCLOSED TO ANY OTHER PARTY WITHOUT THE WRITTEN PERMISSION OF E.H. WACHS & COMPANY.		77-260-12	

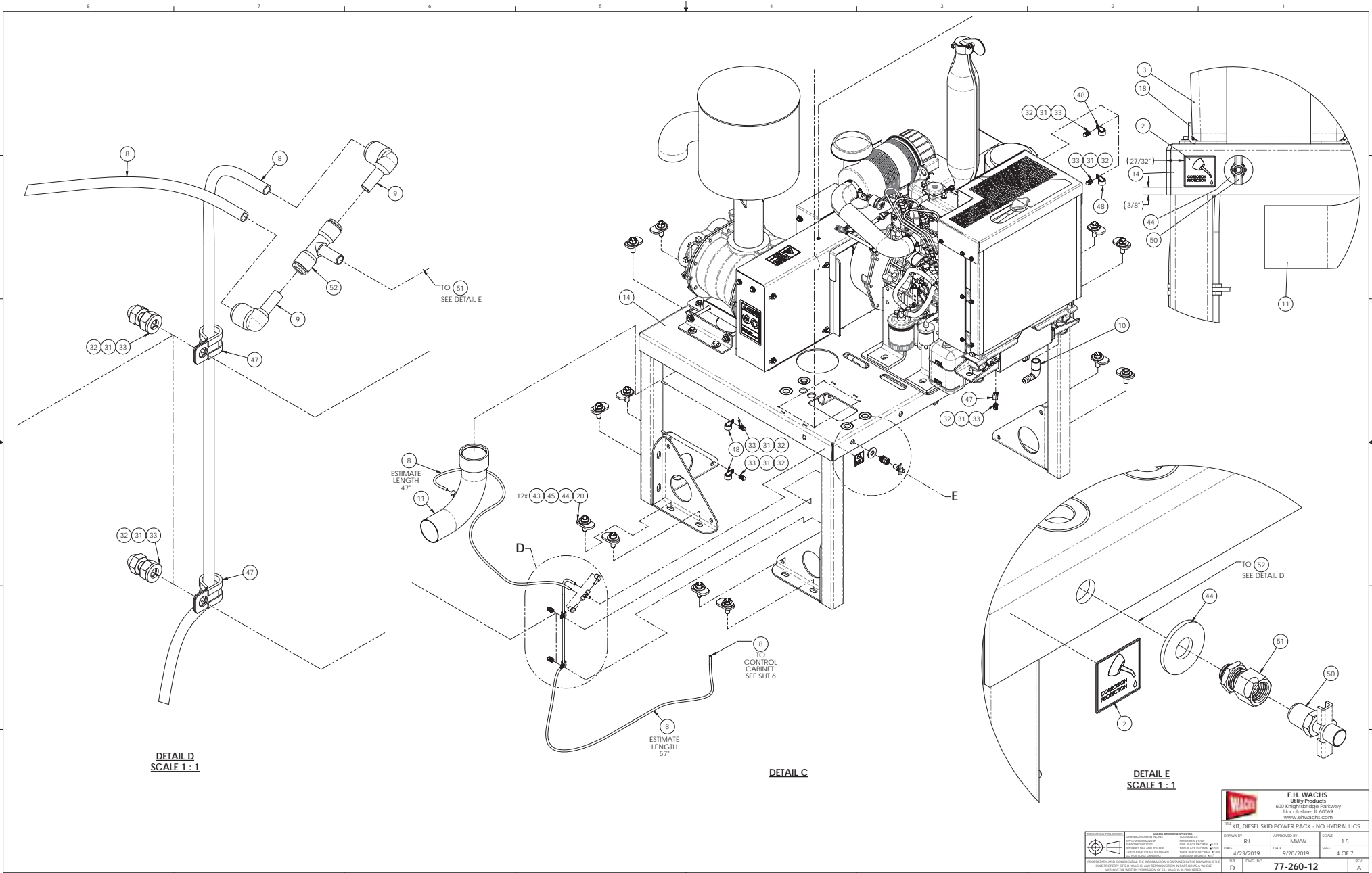

DETAIL D
SCALE 1:1

DETAIL C

DETAIL E
SCALE 1:1

		E.H. WACHS Utility Products 600 Knightbridge Parkway Lincolnshire, IL 60069 www.ehwachs.com	
KIT, DIESEL SKID POWER PACK - NO HYDRAULICS			
DRAWN BY RJ	APPROVED BY BMW	SCALE 1:5	SHEET 4 OF 7
DATE 4/23/2019	DATE 9/20/2019	REV. A	
77-260-12			

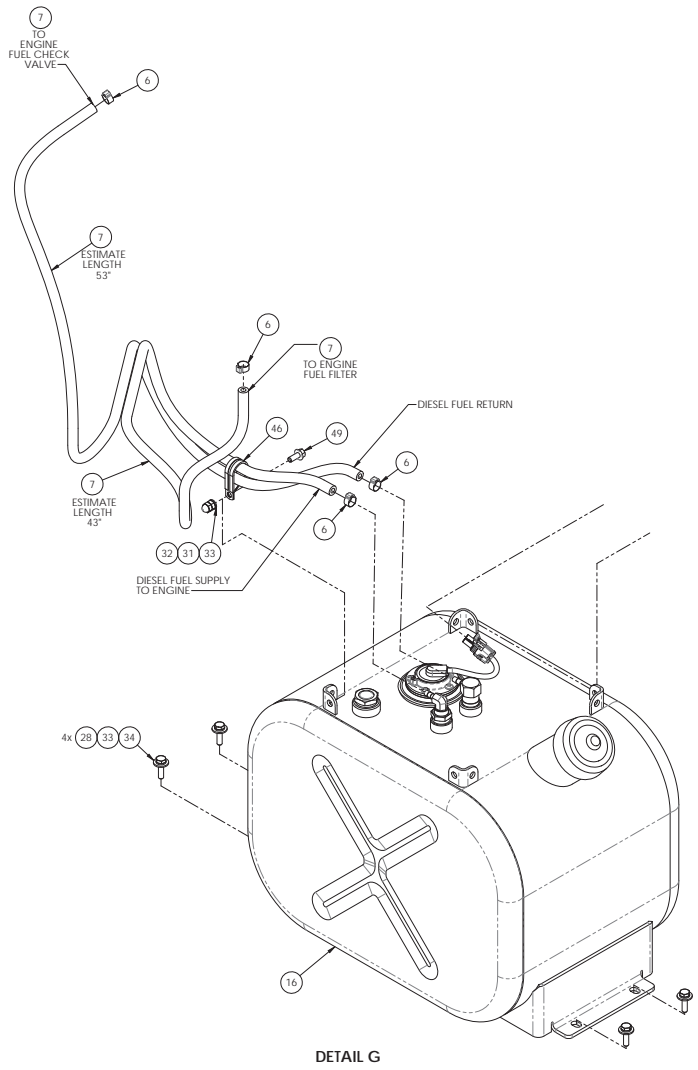

DETAIL G

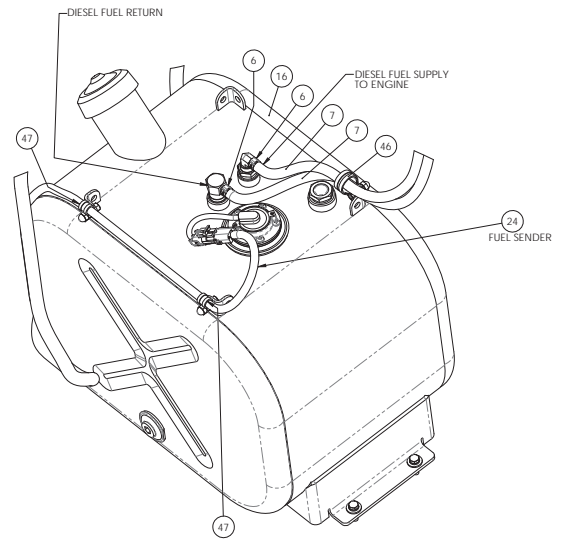
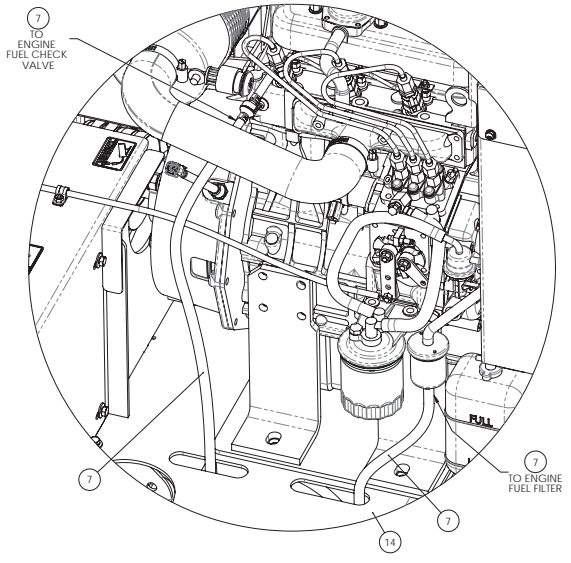

		E.H. WACHS Utility Products 600 Knightbridge Parkway Lincolnshire, IL 60069 www.ehwachs.com	
KIT, DIESEL SKID POWER PACK - NO HYDRAULICS			
DRAWN BY RJ	APPROVED BY BMW	SCALE 1:3	
DATE 4/23/2019	DATE 9/20/2019	SHEET 5 OF 7	
SIZE D	DWG. NO. 77-260-12		REV. A

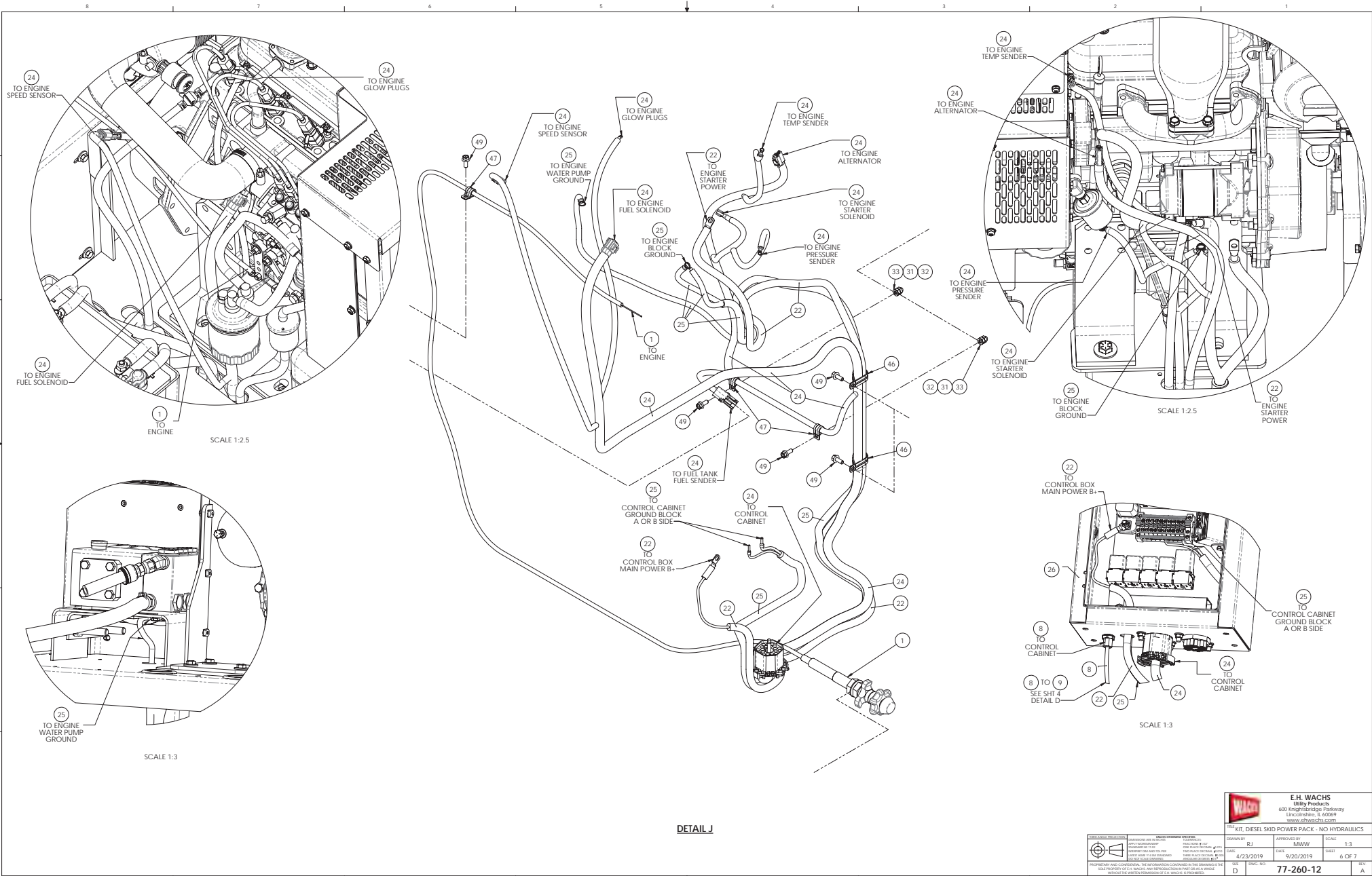

WACHS E.H. WACHS Utility Products
 600 Knightbridge Parkway
 Lincolnshire, IL 60069
 www.ehwachs.com

KIT, DIESEL SKID POWER PACK - NO HYDRAULICS

DESIGNED BY	REVISED BY	APPROVED BY	SCALE
RJ		BMW	1:3
DATE	4/23/2019	DATE	9/20/2019
ISSUE	D	DESCRIPTION	8 OF 7
			REV. A

77-260-12

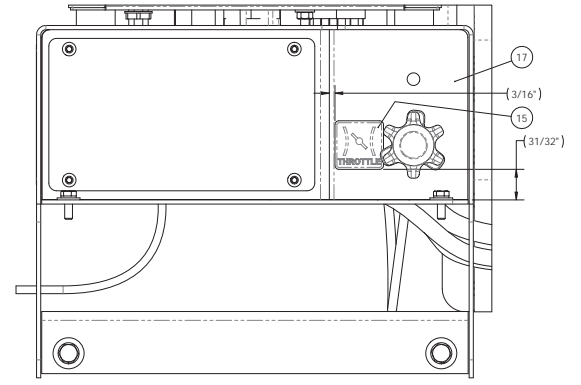
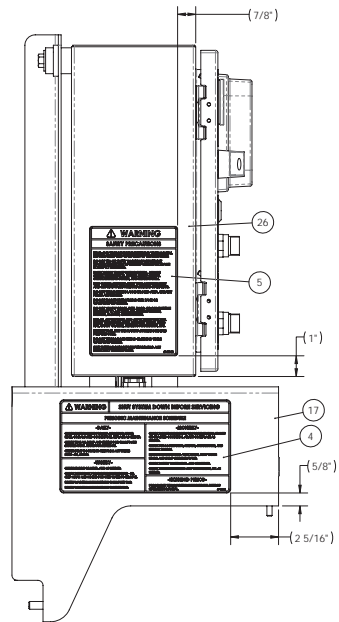

SCALE 1:2

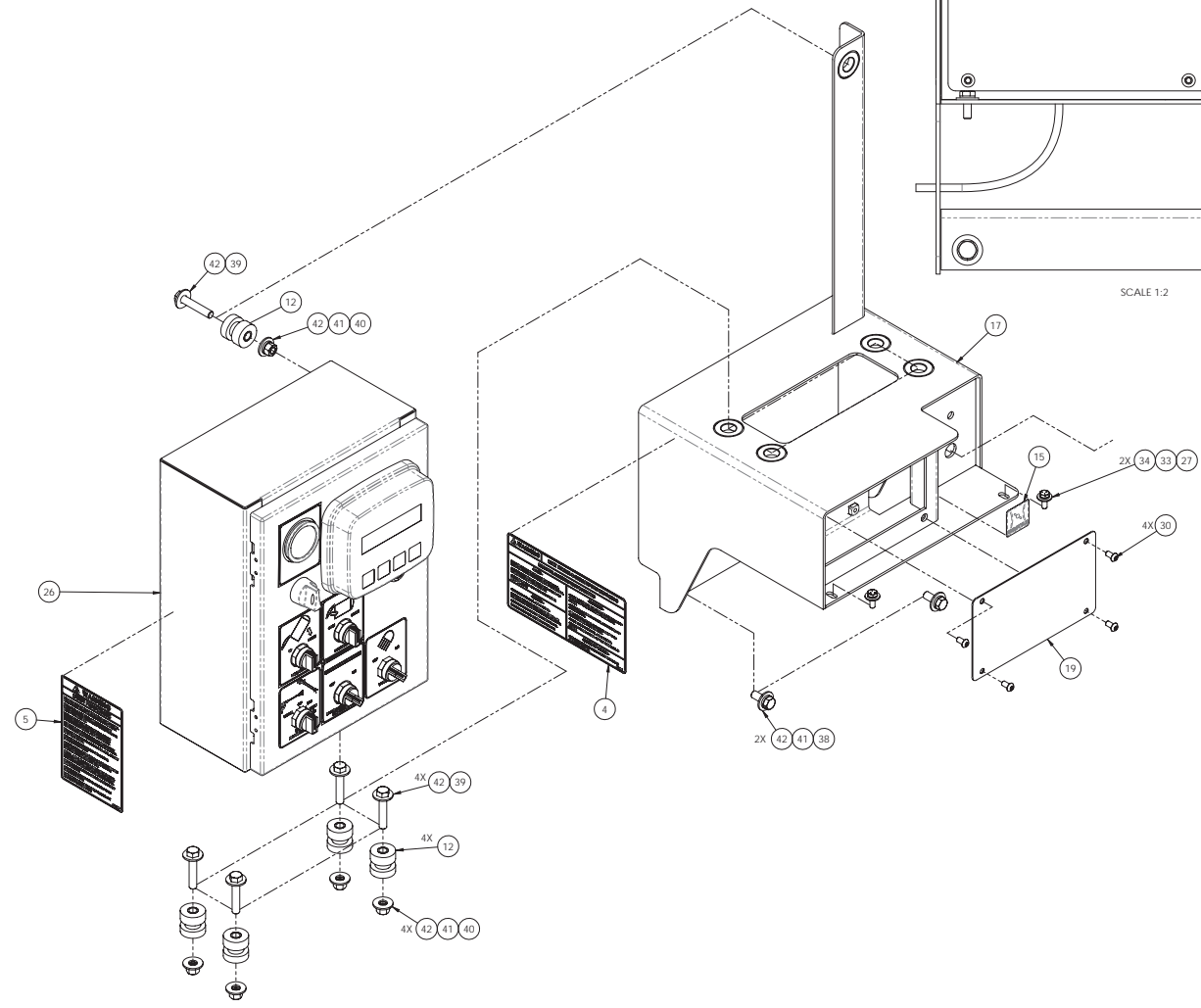

DETAIL H

E.H. WACHS
 Utility Products
 600 Knightbridge Parkway
 Lincolnshire, IL 60069
 www.ehwachs.com

		KIT, DIESEL SKID POWER PACK - NO HYDRAULICS	
DRAWN BY RJ	APPROVED BY RMW	SCALE 1:3	SHEET 7 OF 7
DATE 4/23/2019	DATE 9/20/2019	REV. NO. 1	REV. A
PROPOSED AND CHECKED FOR CONFORMANCE TO THE DRAWING BY THE PERSONS WHOSE NAMES ARE SHOWN HEREIN.		THIS DRAWING IS THE PROPERTY OF E.H. WACHS & COMPANY. IT IS TO BE KEPT IN CONFIDENCE AND NOT TO BE REPRODUCED OR TRANSMITTED IN ANY FORM OR BY ANY MEANS, ELECTRONIC OR MECHANICAL, INCLUDING PHOTOCOPYING, RECORDING, OR BY ANY INFORMATION STORAGE AND RETRIEVAL SYSTEM.	

77-260-12

NOTES:

1. MATERIAL PER COMPONENT
2. FINISH PER COMPONENT
3. KIT REQUIRES OTHER COMPONENTS / SYSTEMS TO FUNCTION
4. IF STORING OR TRANSPORTING, PACKAGE AND SECURE LOOSE COMPONENTS AND HARDWARE
5. SEE HIGHER LEVEL ASSEMBLY FOR SCHEMATICS AND INTERFACES
6. APPROX WEIGHT: 878.703 LB

REVISION HISTORY			
REV.	DESCRIPTION	DATE	APP.
A	NEW RELEASE: ECD 3784	9/20/2019	MMW

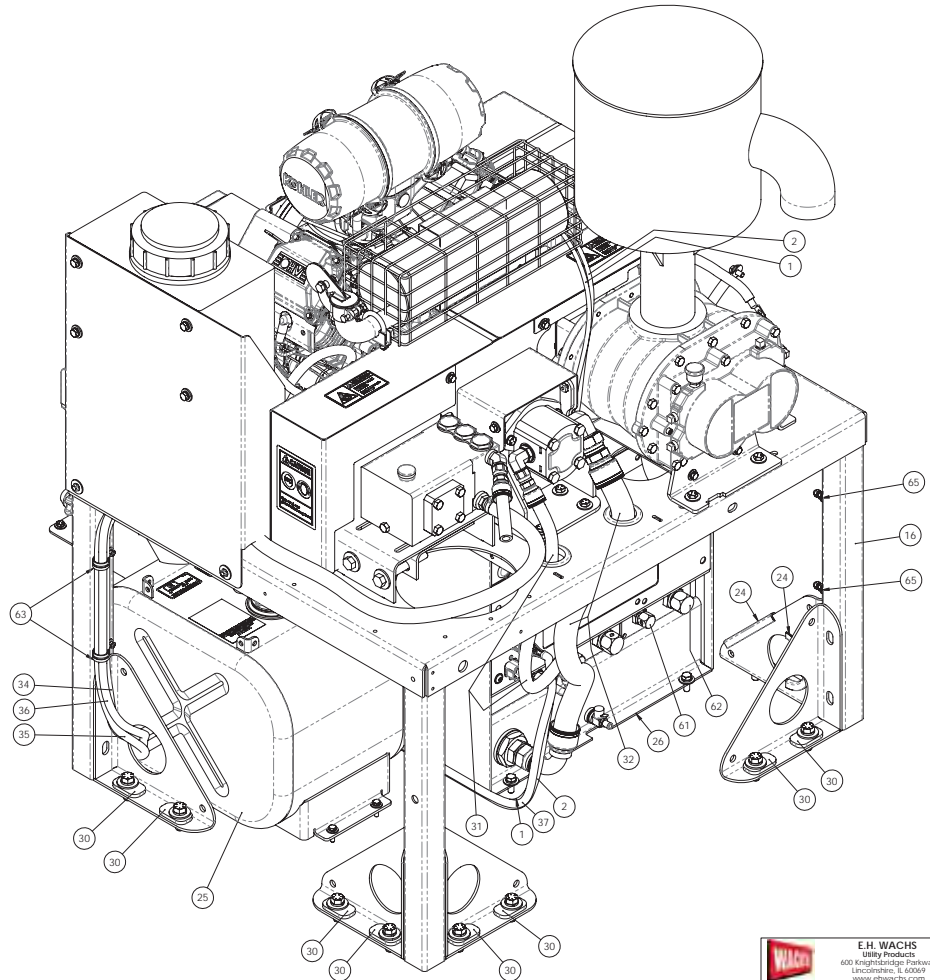
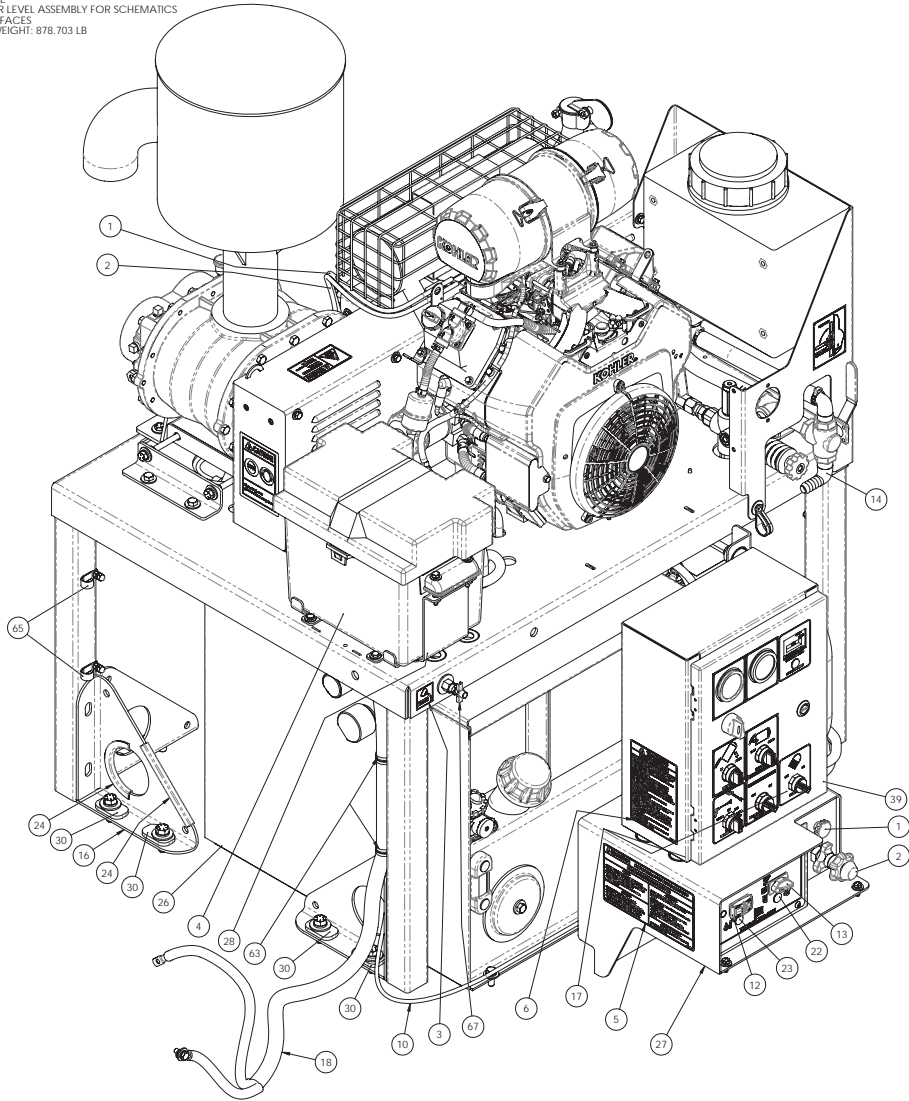

E.H. WACHS
 Utility Products
 600 Knightbridge Parkway
 Lincolnshire, IL 60069
 www.ehwachs.com

KIT, GAS SKID POWER PACK			
CONTRACT	REV.	APPROVED BY	SCALE
		MMW	1:4
DATE	DATE	DATE	SHEET
4/23/2019	9/20/2019		1 OF 7
REV.	DATE		
D			A

77-230-13

ITEM NO.	PART NUMBER	DESCRIPTION	QTY.	ESTIMATE LENGTH
1	17-064-01	CABLE, 9' CHOKE	1	
2	17-065-01	THROTTLE CABLE X 10'	1	
3	59-131-00	LABEL, CORROSION PROTECTION	1	
4	67-051-00	CASE, BATTERY	1	
5	67-112-00	LABEL, MAINTENANCE SCHEDULE	1	
6	67-117-00	LABEL, SAFETY PRECAUTIONS	1	
7	68-158-04	HOSE CLAMP, CRIMP 11.5-14.0MM	3	
8	68-158-17	HOSE CLAMP, CRIMP 9.8-12.3 MM	1	
9	68-159-25	HOSE, 1/4" FUEL- SAE 30R9/CARB	1	(43')
10	68-171-01	TUBING, 1/4" VACUUM RATED NYLON	2	(47'), (57')
11	68-172-13	ADAPTER, 1/4" PLUG-IN X 1/4" PTC 90	2	
12	68-179-10	SEALED ROCKER SWITCH, 3 POSITION 2 LAMP	1	
13	68-179-11	SELECTOR SWITCH, 3 POSITION	1	
14	68-243-30	ELBOW, 3/4" NPT-M X 3/4" HOSE BARB - NYLON	1	
15	77-064-01	ASSEMBLY, INLET ELBOW	1	
16	77-230-03	POWERPACK, 27 HP GAS - NO CTRLS	1	
17	77-242-01	ISOLATION MOUNT, 35 LB	5	
18	77-248-00	HARNES, HPU TO BATTERY	1	
19	77-267-02	LABEL, HYDRAULIC CONTROLS 3 POSITION	1	
20	77-267-05	LABEL, THROTTLE	1	
21	77-267-06	LABEL, CHOKE	1	
22	77-272-10	INDICATOR, GREEN LED JWPF CONNECTOR	1	
23	77-272-20	INDICATOR, RED LED JWPF CONNECTOR	1	
24	77-277-50	PVC EDGE TRIM, 0.090" TO 0.190" EDGE THICKNESS	2	(6'), (7')
25	77-282-20	GASOLINE FUEL TANK, 10 GALLON ALUMINUM	1	
26	77-285-03	RESERVOIR ASSEMBLY, 3 CIRCUIT SKIDS	1	
27	77-290-10	WELDMENT, CONTROL MOUNT	1	
28	77-290-14	BATTERY HOLD DOWN BRACKET	2	
29	77-290-19	CONTROL PANEL	1	
30	77-290-40	CLAMPING WASHER	12	
31	77-292-02	32 1/8" HOSE ASSEMBLY, -08 FJ X -08 FJ 90 X -08 HOSE	1	
32	77-292-03	33 1/8" HOSE ASSEMBLY, -16 F JIC X -16 F JIC 90 X -16 HOSE	1	
33	77-313-50	BATTERY, DEEP CYCLE 12V	1	
34	77-520-03-14	WIRE HARNESS, GAS ENGINE GRAND VMT	1	
35	77-520-03-26	WIRE HARNESS, POWER TO CTL BOX	1	
36	77-520-03-27	WIRE HARNESS, GND TO CTL BOX - GAS	1	
37	77-520-03-30	WIRE HARNESS, RESERVOIR CONTROLS	1	
38	77-520-03-31	WIRE HARNESS, BATTERY TO ENGINE	1	
39	77-520-20	CONTROL CABINET, VMT GAS	1	
40	90-018-50	PLUG, SAE-8 ORB	1	
41	90-051-07	HHCS, 1/4-20 X 3/4 GRADE 5 Zn	4	
42	90-051-10	HHCS, 1/4-20 X 1	8	
43	90-051-22	HHCS, 1/4-20 X 2-1/4	4	
44	90-052-05	BHCS, 1/4-20 X 1/2	4	
45	90-055-01	NUT, 1/4-20 HEX	14	
46	90-055-18	NUT, 1/4-20 ACORN	8	
47	90-055-52	WASHER, 1/4 SPLIT RING	24	
48	90-055-53	WASHER, FLAT, 1/4	22	
49	90-061-07	HHCS, 5/16-18 x 3/4	3	
50	90-065-51	WASHER, 5/16 SPLIT RING	3	
51	90-065-52	WASHER, 5/16 FLAT	3	
52	90-071-10	HHCS, 3/8-16 X 1	6	
53	90-071-20	HHCS, 3/8-16 X 2 GR 5 ZN	5	
54	90-075-01	NUT, 3/8-16 HEX GR 5 ZN	5	
55	90-075-52	WASHER, 3/8 SPLIT RING	11	
56	90-075-53	WASHER, 3/8 FLAT	16	

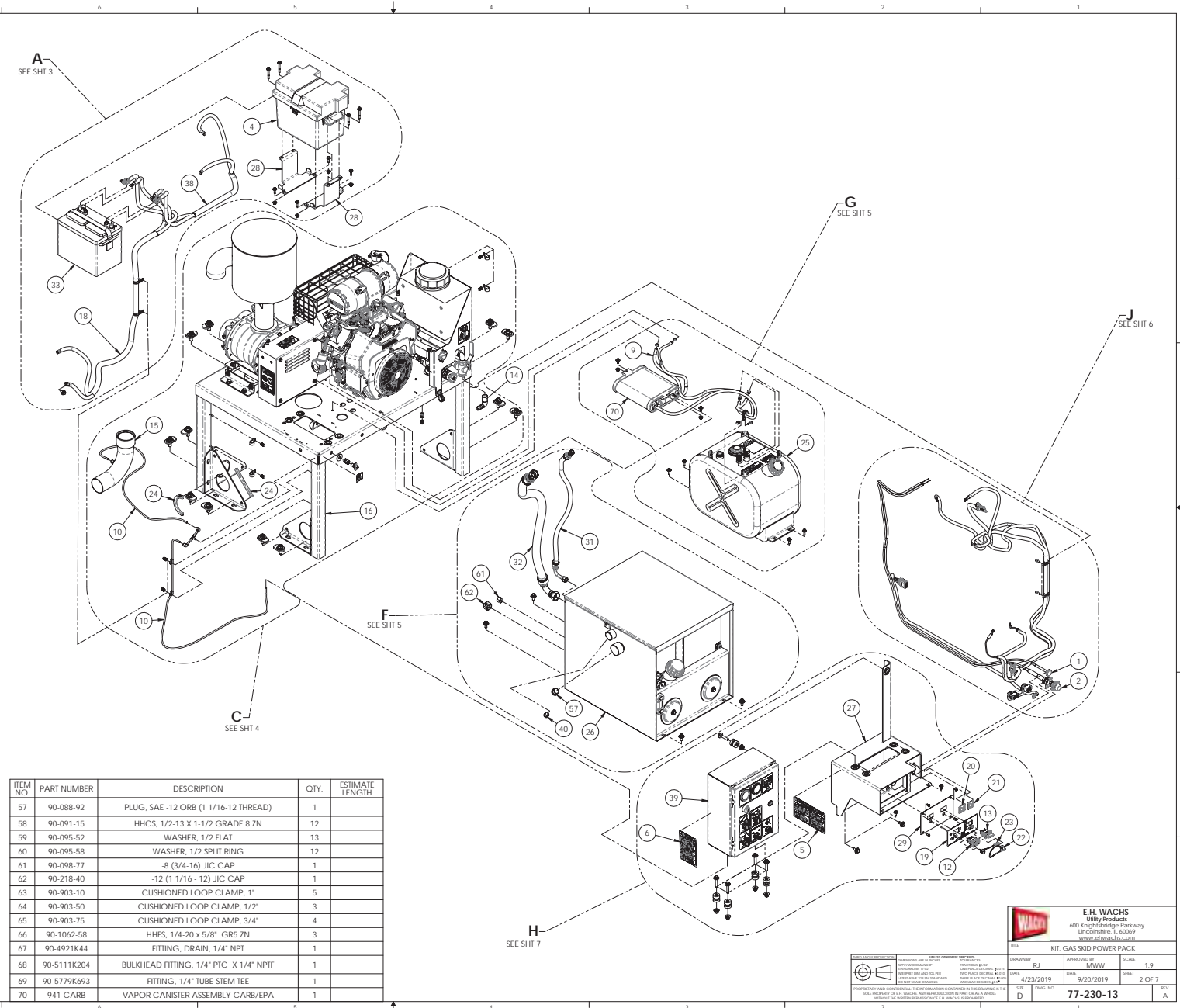

ITEM NO.	PART NUMBER	DESCRIPTION	QTY.	ESTIMATE LENGTH
57	90-088-92	PLUG, SAE -12 ORB (1 1/16-12 THREAD)	1	
58	90-091-15	HHCS, 1/2-13 X 1-1/2 GRADE 8 ZN	12	
59	90-095-52	WASHER, 1/2 FLAT	13	
60	90-095-58	WASHER, 1/2 SPLIT RING	12	
61	90-098-77	-8 (3/4-16) JIC CAP	1	
62	90-218-40	-12 (1 1/16 - 12) JIC CAP	1	
63	90-903-10	CUSHIONED LOOP CLAMP, 1"	5	
64	90-903-50	CUSHIONED LOOP CLAMP, 1/2"	3	
65	90-903-75	CUSHIONED LOOP CLAMP, 3/4"	4	
66	90-1062-58	HHFS, 1/4-20 x 5/8" GR5 ZN	3	
67	90-4921K44	FITTING, DRAIN, 1/4" NPT	1	
68	90-5111K204	BULKHEAD FITTING, 1/4" PTC X 1/4" NPTF	1	
69	90-5779K693	FITTING, 1/4" TUBE STEM TEE	1	
70	941-CARB	VAPOR CANISTER ASSEMBLY-CARB/EPA	1	

WACHS

PROPOSED AND CHECKED BY: []
 DRAWN BY: []
 DATE: 4/23/2019

E.H. WACHS
 Utility Products
 600 Knightbridge Parkway
 Lincolnshire, IL 60069
 www.ehwachs.com

KIT, GAS SKID POWER PACK	
DATE: 9/20/2019	SCALE: 1:1
DESIGNED BY: RJ	APPROVED BY: []
DATE: 4/23/2019	DATE: 9/20/2019
REV: 2	SHEET: 2 OF 7
77-230-13	

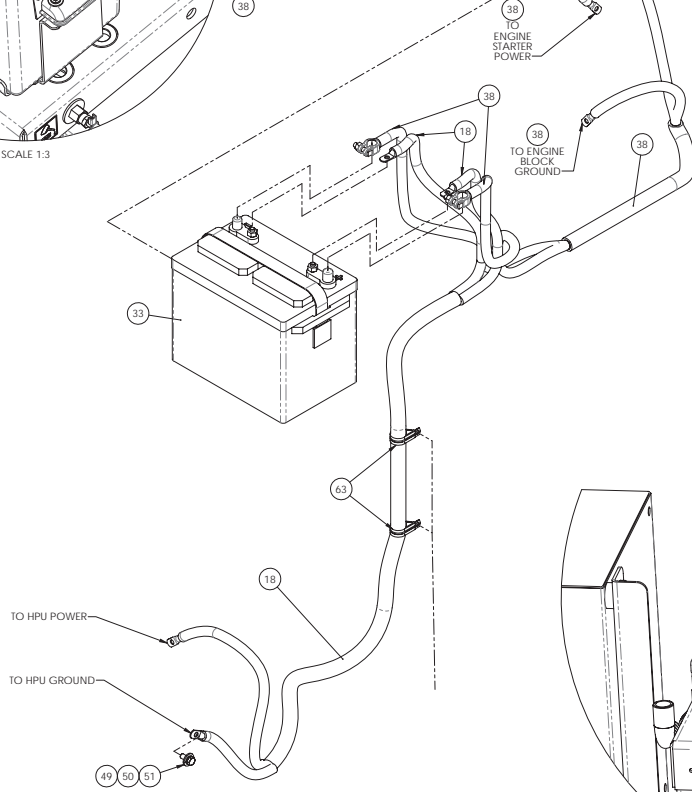
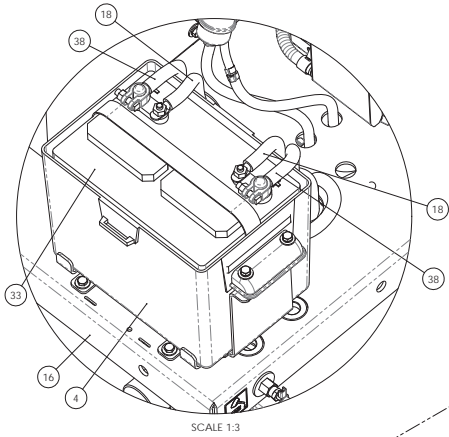

DETAIL A

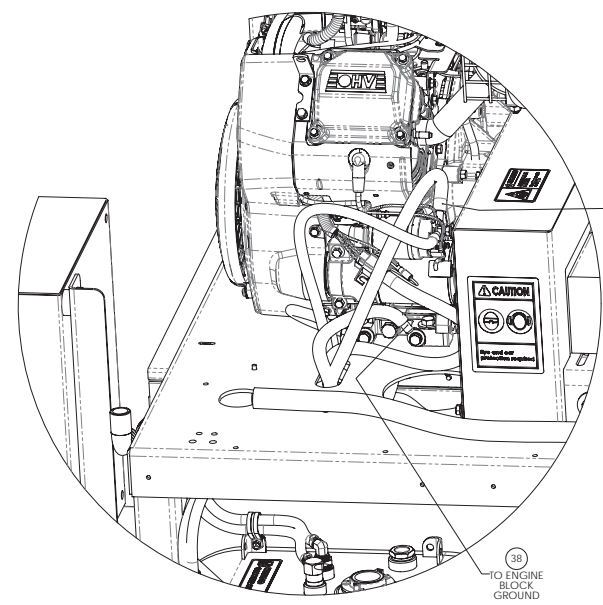
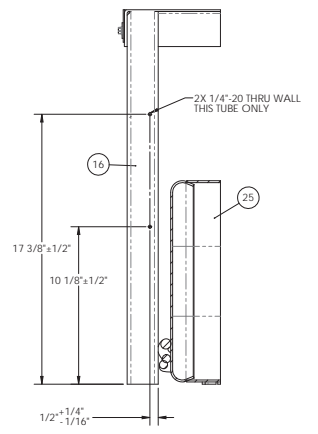
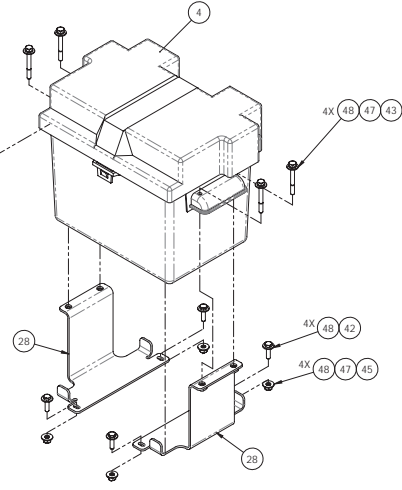

SCALE 1:3
ITEMS REMOVED FOR CLARITY

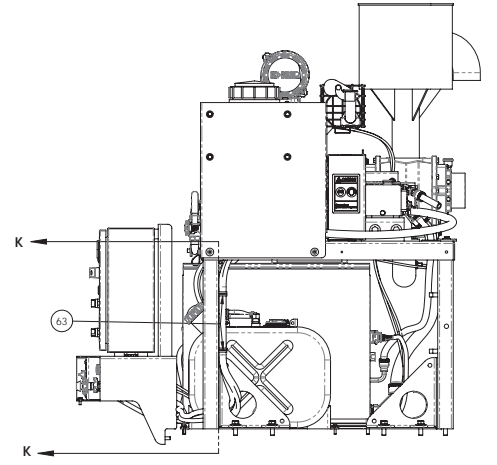

SCALE 1:8

		E.H. WACHS Utility Products 600 Knightbridge Parkway Lincolnshire, IL 60069 www.ehwachs.com	
KIT, GAS SKID POWER PACK		DATE: 4/23/2019	
DRAWN BY: RJ	APPROVED BY: RWV	DATE: 9/20/2019	SCALE: 1:4
SHEET: 3 OF 7	REV: A	PART NO: 77-230-13	

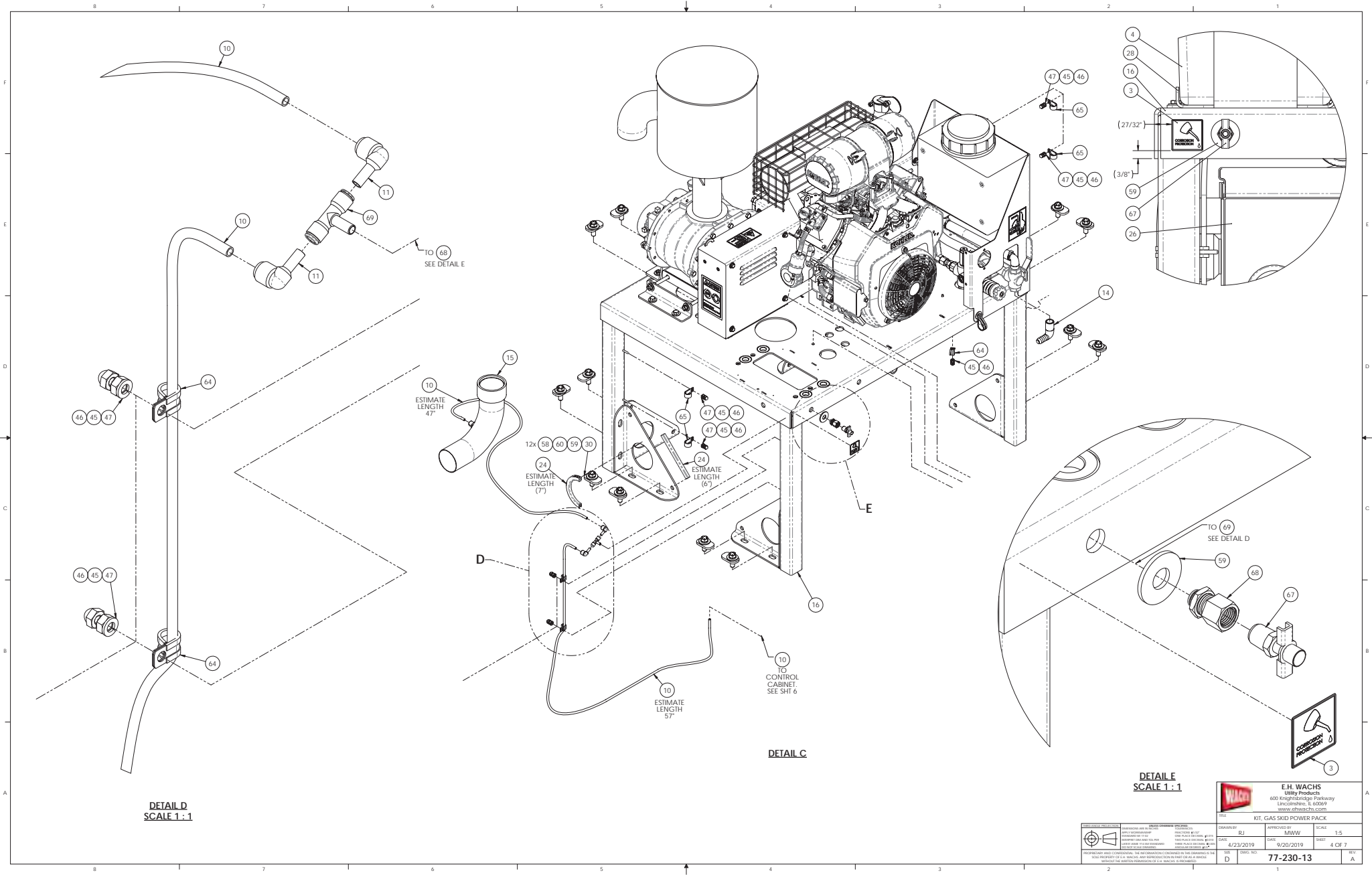

DETAIL D
SCALE 1:1

DETAIL C

DETAIL E
SCALE 1:1

		E.H. WACHS Utility Products 600 Knightbridge Parkway Lincolnshire, IL 60069 www.ehwachs.com	
KIT, GAS SKID POWER PACK			
DRAWN BY RJ	APPROVED BY RMW	DATE 4/23/2019	SCALE 1:5
SHEET D	SHEET 4 OF 7	REV. A	PART NO. 77-230-13

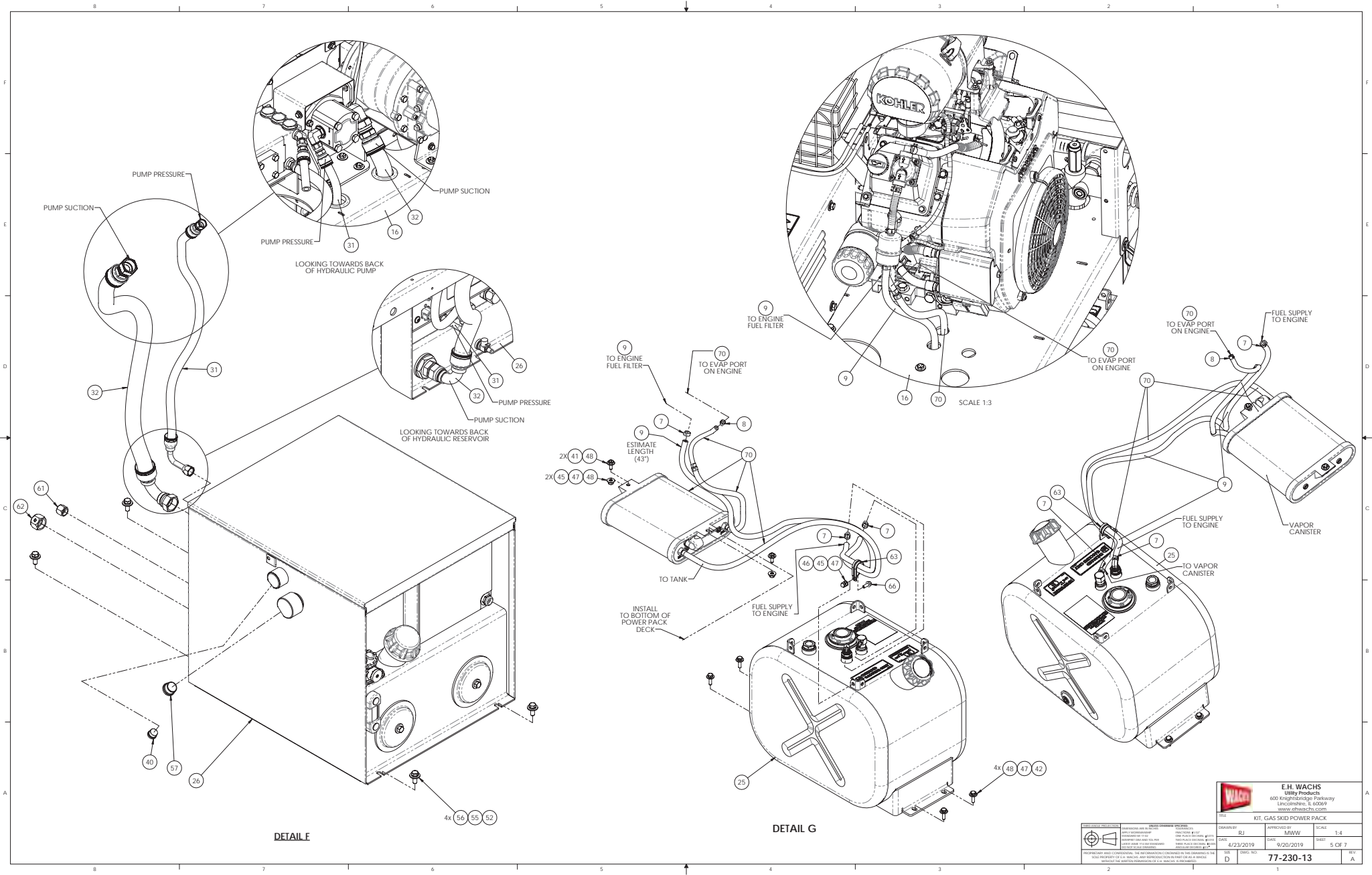

		E.H. WACHS Utility Products 600 Knightbridge Parkway Lincolnshire, IL 60069 www.ehwachs.com	
DATE	4/23/2019	DATE	9/20/2019
DESIGNED BY	RJ	APPROVED BY	BMW
SCALE	1:4	SHEET	5 OF 7
KIT, GAS SKID POWER PACK		REV.	A
77-230-13			

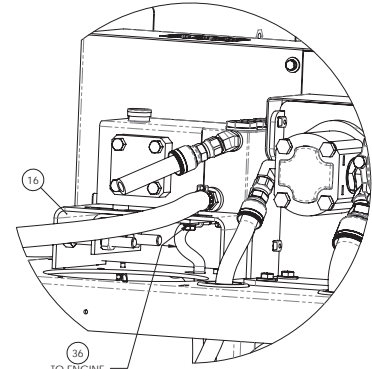
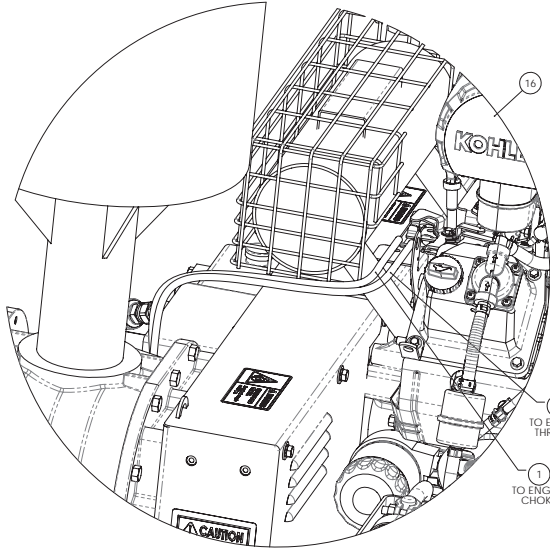

SCALE 1:3

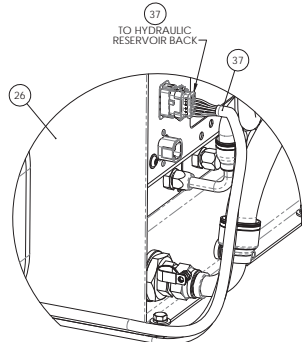

SCALE 1:3

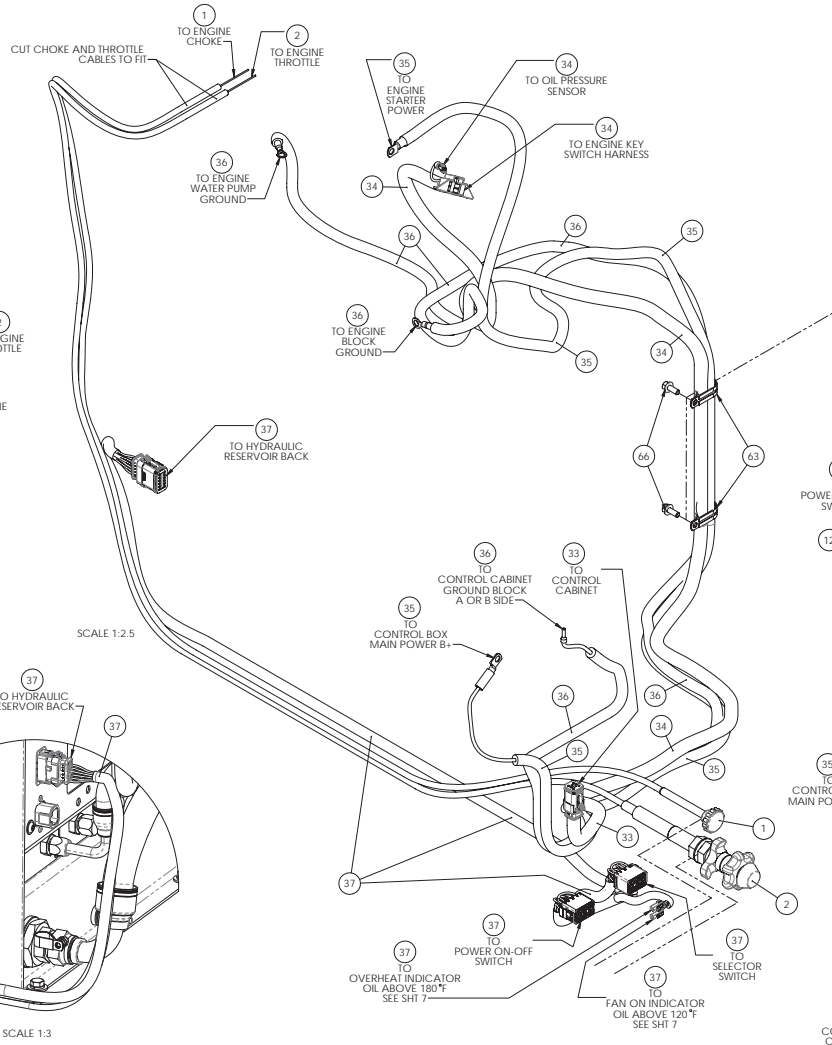

DETAIL J

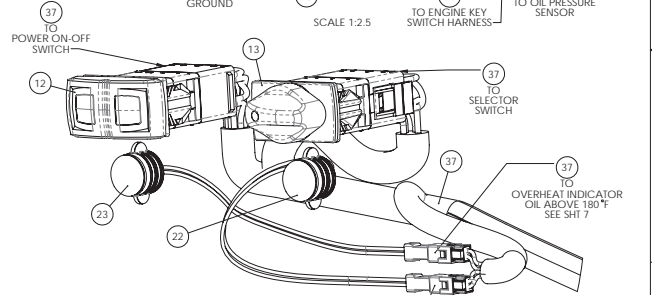
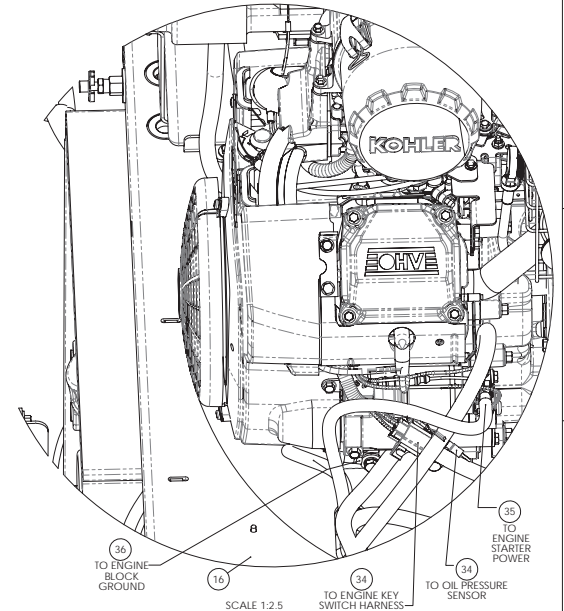

SCALE 1:1

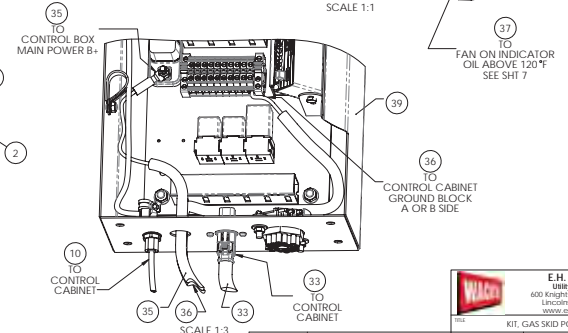

SCALE 1:3

		E.H. WACHS Utility Products 600 Knightbridge Parkway Lincolnshire, IL 60069 www.ehwachs.com	
REV	DATE	APPROVED BY	SCALE
D	4/23/2019	RJ	1:3
DESCRIPTION		DATE	SHEET
KIT, GAS SKID POWER PACK		9/20/2019	6 OF 7
DRAWN BY		DATE	REV.
77-230-13			A

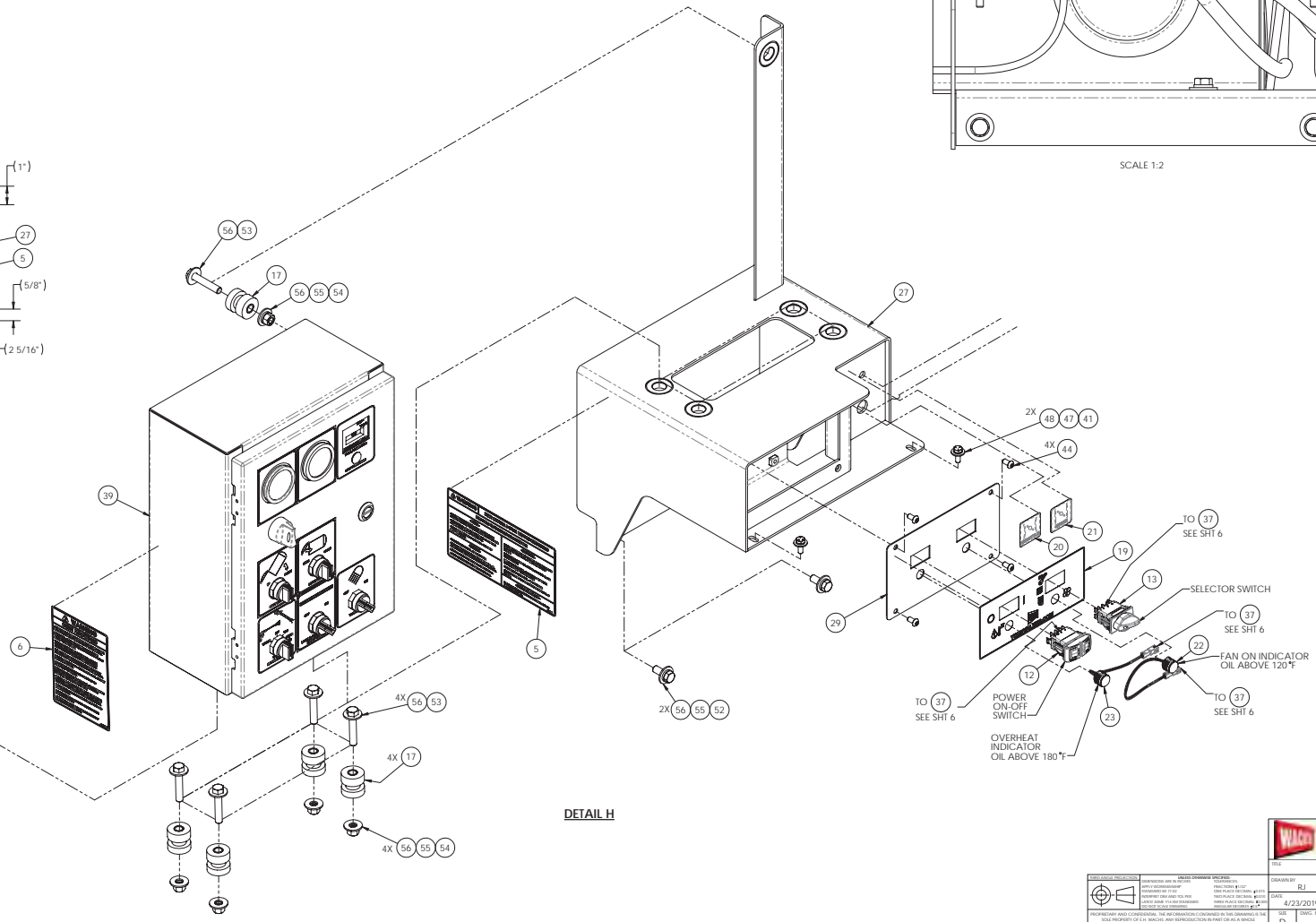
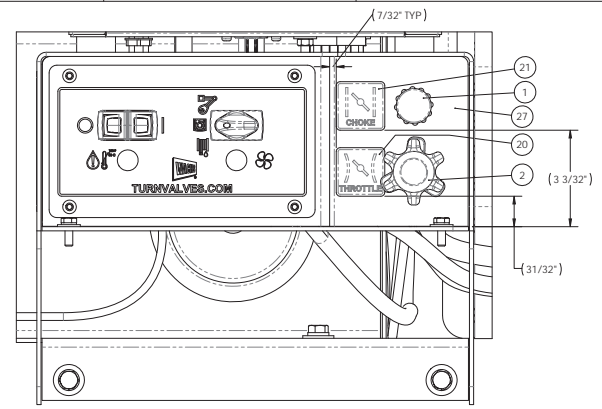
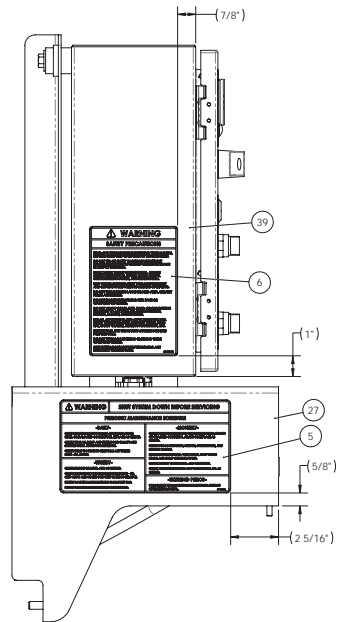

DETAIL H

		E.H. WACHS Utility Products 600 Knightbridge Parkway Lincolnshire, IL 60069 www.ehwachs.com	
KIT, GAS SKID POWER PACK			
DRAWN BY RJI	CHECKED BY RJI	APPROVED BY RMW	SCALE 1:3
DATE 4/23/2019	DATE 9/20/2019	SHEET 7 OF 7	REV. A
77-230-13			

PROCEEDURE AND CAUTIONS: SEE OPERATIONAL MANUAL FOR INFORMATION ON THE OPERATION OF THIS PRODUCT. SEE THE MANUAL AND OPERATIONAL MANUAL FOR ALL WARNINGS AND CAUTIONS FOR SAFETY INFORMATION OF ALL WACHS PRODUCTS.

- NOTES:
1. MATERIAL: PER COMPONENT
 2. FINISH: PER COMPONENT
 3. USE SHIMS AS NEEDED FOR ENGINE AND HYDRAULIC PUMP ALIGNMENT
 4. APPROX. WEIGHT: 535.469 LBS.

REVISION HISTORY			
REV	DESCRIPTION	DATE	APR
A	NEW RELEASE PER ECO 3475	5/23/2018	HMA
B	REPLACED 77-285-00 & 77-120-00 WITH 77-285-10 ECO 3665	9/21/2018	BC
C	ADD ENGINE HYDRO PUMP SHIMS, REPLACE 078-035-32 WITH 078-075-52, REPLACE 77-151-01-05 WITH 77-151-01-06, 77-151-01-05-0206, 5 REPLACED WITH 9-02-18-15, 0206-3, ADD TORQUEING INZ AND LOCTITE INFO PER ECO 3938	10/22/2019	HMA

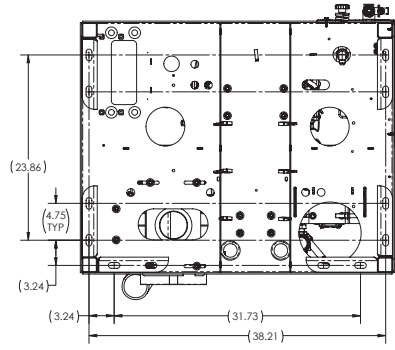
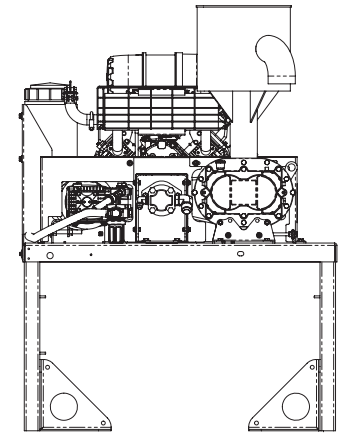
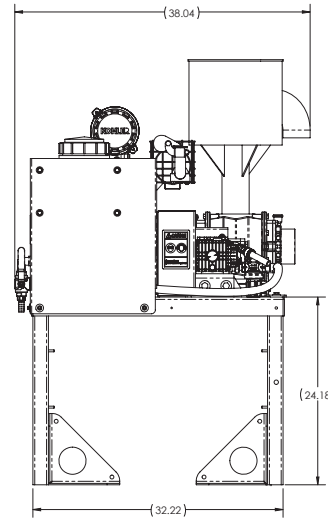
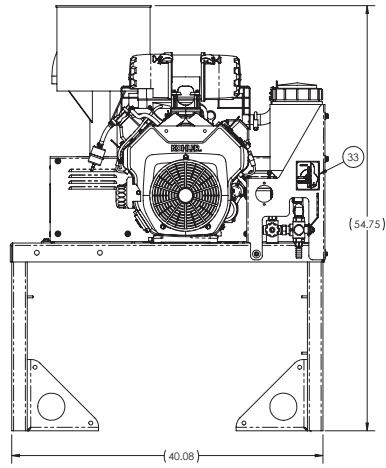
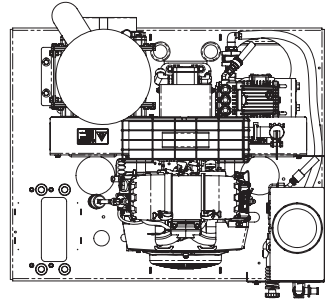

		E. H. WACHS Utility Products 600 Knightbridge Parkway Lincolnshire, IL 60069 www.ehwachs.com	
FILE: POWERPACK, 27 HP GAS - NO CTRLS		DATE: 12/4/2017	DATE: 1/12/2018
DESIGNED BY: HMA	APPROVED BY: BMW	SCALE: 1:1	SHEET: 1 OF 6
PROFESIONER AND CONSULTANT, THE REPRESENTATION COMPANY FOR THE MANUFACTURE OF THE PRODUCT FOR THE TERRITORY OF E.H. WACHS S.P.A. IN ITALY		REV. NO: 77-230-03	REV. C

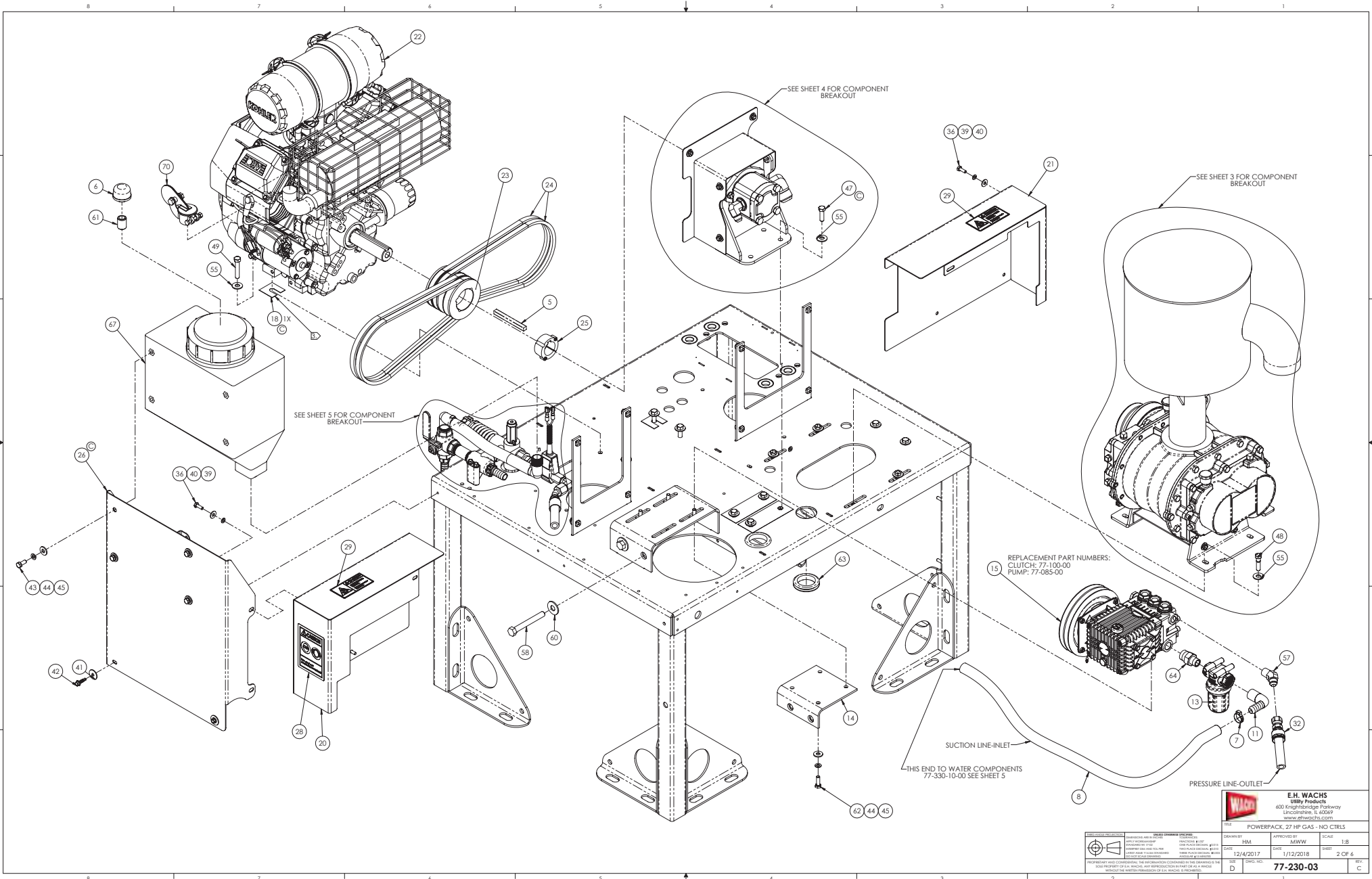

E.H. WACHS
 Utility Products
 600 Knightbridge Parkway
 Lincolnshire, IL 60069
 www.ehwachspco.com

FILE	POWERPACK, 27 HP GAS - NO CTRLS	SCALE	1:8
DESIGNED BY	HM	APPROVED BY	BMWV
DATE	12/4/2017	DATE	1/12/2018
DWG. NO.	77-230-03	SHEET	2 OF 6
PROPERTIES AND CONDITIONS: SEE REFERENCE DRAWING FOR DIMENSIONS AND TOLERANCES. ALL DIMENSIONS ARE IN INCHES UNLESS OTHERWISE SPECIFIED. FINISHES: UNLESS OTHERWISE SPECIFIED, ALL DIMENSIONS ARE TO BE MAINTAINED AS SHOWN.		REV. C	

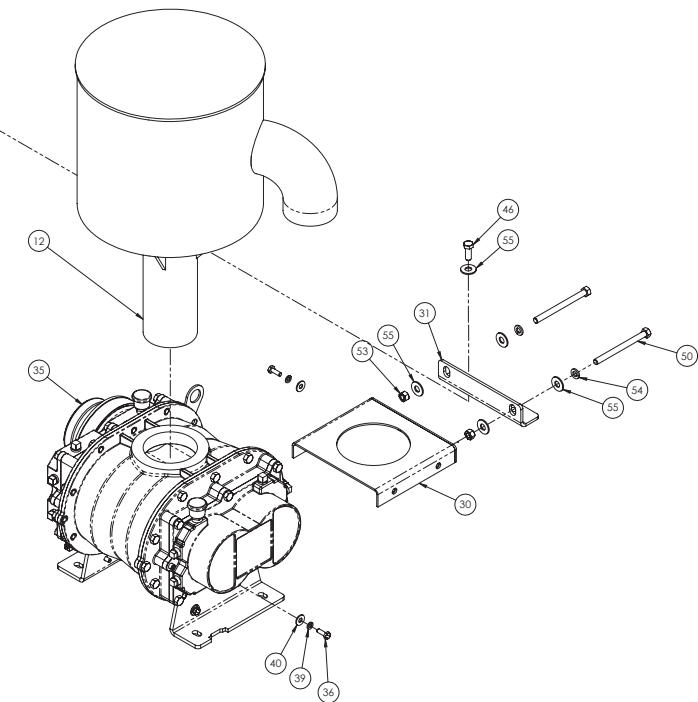
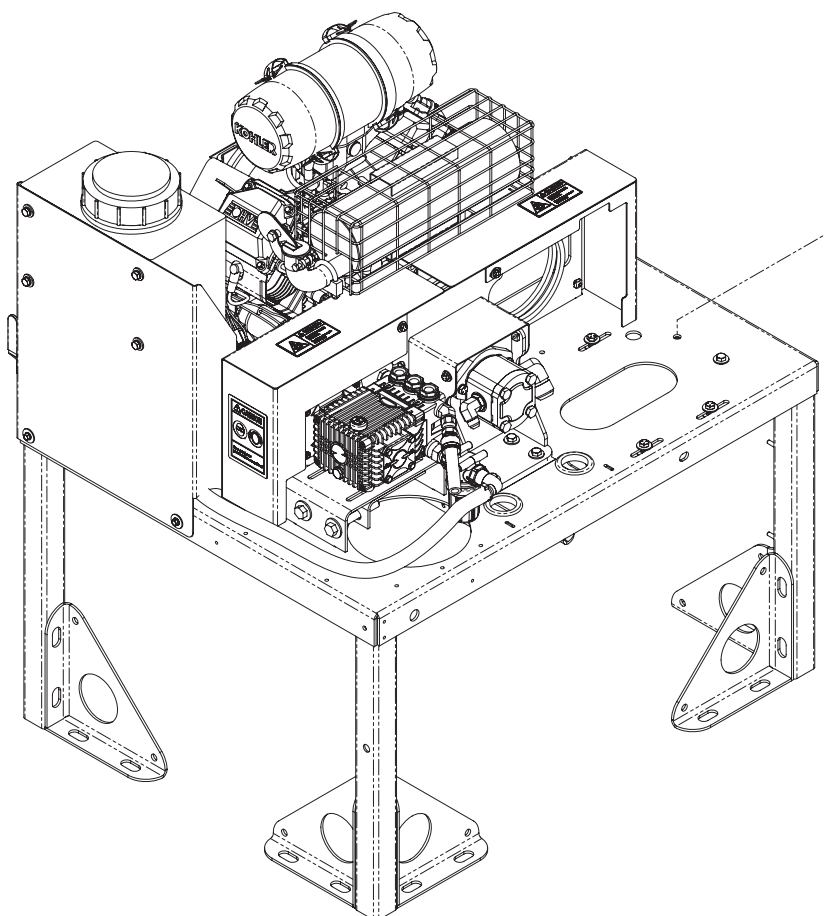

 E.H. WACHS Utility Products 600 Knightbridge Parkway Lincolnshire, IL 60069 www.ehwachs.com	
TITLE: POWERPACK, 27 HP GAS - NO CTRLS	
DRAWN: HM	APPROVED: RWV
DATE: 12/4/2017	DATE: 1/12/2018
SIZE: D	SHEET: 3 OF 6
77-230-03	

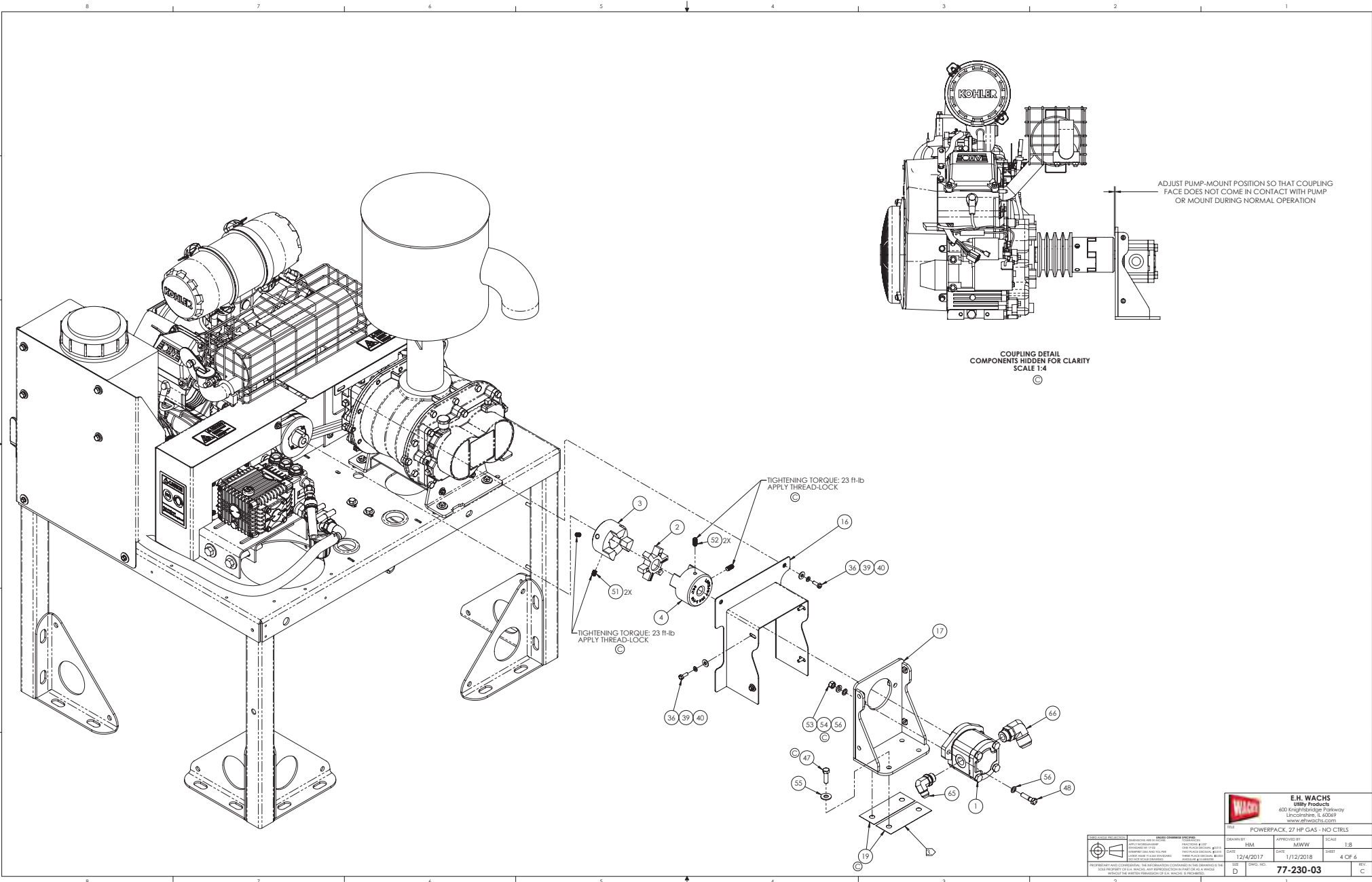

E.H. WACHS
 Utility Products
 600 Knightbridge Parkway
 Lincolnshire, IL 60069
 www.ehwachs.com

FILE	POWERPACK, 27 HP GAS - NO CTRLS
DESIGNER	HM
APPROVED	BMW
DATE	12/4/2017
DATE	1/12/2018
SHEET	4 OF 6
REV.	C
77-230-03	

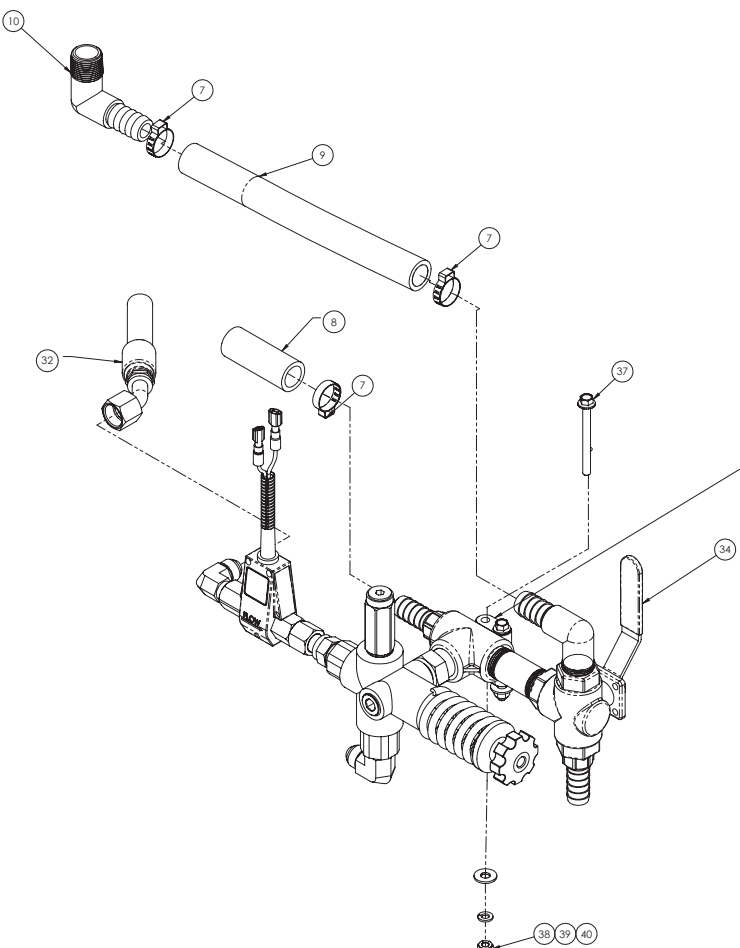

77-163-46 CAN BE SUBSTITUTED
WITH 77-163-49; REQUIRES
90-051-10 & 90-055-53 FASTENERS

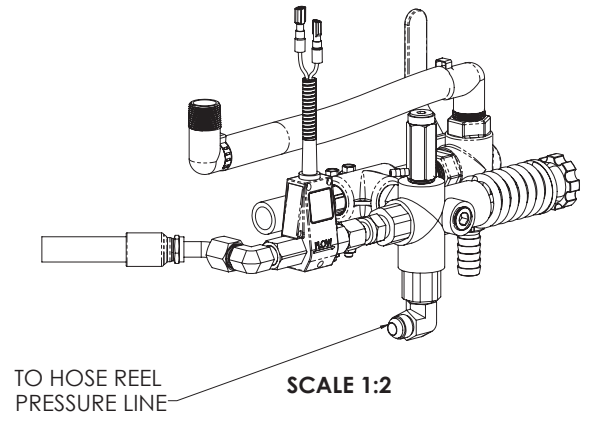
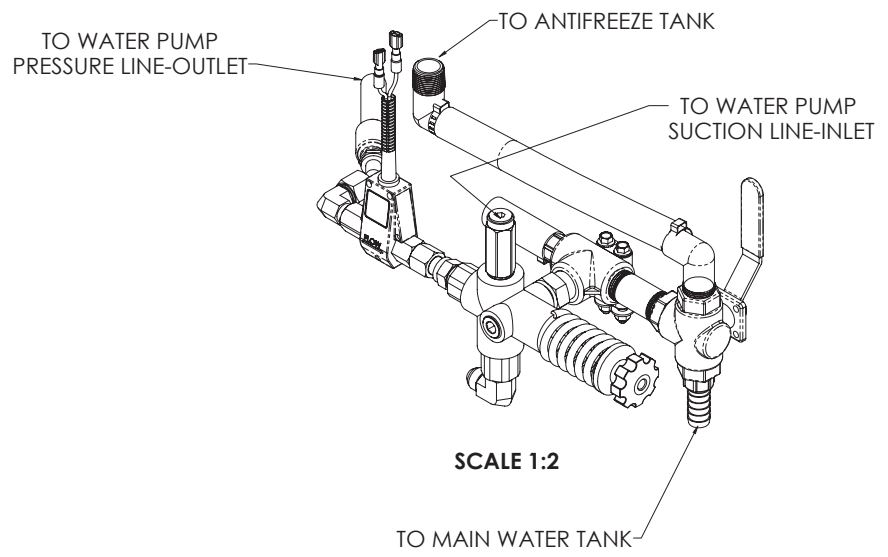

		E.H. WACHS Utility Products 600 Knightbridge Parkway Lincolnshire, IL 60069 www.ehwachs.com	
TITLE POWERPACK, 27 HP GAS - NO CTRLS			
DRAWN BY HM	APPROVED BY RWV	SCALE 1:8	SHEET 5 OF 6
DATE 12/4/2017	DATE 1/12/2018	D	77-230-03
<small> PROPRIETARY AND CONFIDENTIAL. THIS INFORMATION CONTAINS THE TRADE SECRETS AND PROPRIETARY INFORMATION OF E.H. WACHS. ANY REPRODUCTION OR DISSEMINATION OF THIS INFORMATION TO ANY OTHER PERSON WITHOUT THE WRITTEN PERMISSION OF E.H. WACHS IS PROHIBITED. </small>			

ITEM	PART NUMBER	QTY	DESCRIPTION	LENGTH
1	17-060-00	1	PUMP, HYDRAULIC GEAR	
2	17-061-30	1	SPIDER, L110 HYTREL - CLOSED CENTER	
3	17-061-40	1	HUB, AL110 1-7/16" BORE (3/16" X 3/8" KEY)	
4	17-061-50	1	HUB, AL110 3/4" BORE (3/32" X 3/16" KEY)	
5	67-294-00	1	KEYSTOCK, 3/8" X 3/8" (INCH)	4"
6	68-138-02	1	Strainer, Antifreeze Tank	
7	68-158-16	4	HOSE CLAMP, CRIMP-23.9 - 27.1 MM	
8	68-233-00	1	HOSE 3/4" LP LOCK ON	38"
9	68-233-00	1	HOSE, 3/4" LP LOCK ON	10"
10	68-243-30	1	ELBOW, 3/4" NPT-M X 3/4" HOSE BARB - NYLON	
11	68-243-30	1	ELBOW, 3/4" NPT-M X 3/4" HOSE BARB - NYLON	
12	77-014-01	1	SILENCER	
13	77-068-25	1	STRAINER	
14	77-082-02	1	WELDMENT, PRESSURE WASHER TENSION	
15	77-085-10	1	PUMP & CLUTCH ASSEMBLY, PRESSURE WASHER	
16	77-087-19	1	WELDMENT, HYD PUMP GUARD	
17	77-087-20	1	WELDMENT, HYD PUMP MOUNT	
18	77-087-27	1	ENGINE SHIM KIT	
19	77-087-28	2	PUMP MOUNT SHIM KIT	
20	77-088-20	1	WELDMENT, WATER PUMP, BELT GUARD	
21	77-089-20	1	WELDMENT, BLOWER BELT GUARD	
22	77-101-02	1	ENGINE, 27 HP KOHLER GAS WITH MUFFLER	
23	77-110-50	1	SHEAVE, QUAD GROOVE	
24	77-111-52	4	BELT, AX35	
25	77-112-00	1	BUSHING, 1.610 X 1-7/16"	
26	77-151-01-06	1	PANEL, ANTIFREEZE SUPPORT	
27	77-151-30	1	WELDMENT, GASOLINE POWERPACK	
28	77-160-05	2	LABEL, EYE AND EAR PROTECTION	
29	77-160-13	2	LABEL, MOVING PARTS PRESENT	
30	77-228-01	1	WELDMENT, BLOWER TENSION	
31	77-229-01	1	ANGLE BRACKET	
32	77-330-01-01	1	HOSE ASSEMBLY	

ITEM	PART NUMBER	QTY	DESCRIPTION	LENGTH
33	77-330-03-01	1	LABEL, TANK SELECT VALVE	
34	77-330-10-00	1	ASSEMBLY, WATER CONTROLS POWERPACK VMI-2	
35	77-486-00	1	BLOWER ASSEMBLY	
36	90-051-07	18	HHCS, 1/4-20 X 3/4 GRADE 5 Zn	
37	90-051-27	2	HHCS, 1/4-20 X 2-3/4 SERRATED GRADE 5	
38	90-055-01	2	NUT, 1/4-20 HEX	
39	90-055-52	20	WASHER, 1/4 SPLIT RING	
40	90-055-53	20	WASHER, FLAT, 1/4	
41	90-055-57	3	WASHER, 1/4 X 1 OD FENDER 18-BSS	
42	90-059-03	3	HHSD, 1/4 X 1 #3PT SS	
43	90-061-07	4	HHCS, 5/16-18 X 3/4	
44	90-065-51	8	WASHER, 5/16 SPLIT RING	
45	90-065-52	8	WASHER, 5/16 FLAT	
46	90-071-10	2	HHCS, 3/8-16 X 1	
47	90-071-12	4	HHCS, 3/8-16 X 1-1/4 GRADE 5	
48	90-071-14	6	HHCS, 3/8-16 X 1-1/2 GR5 ZN	
49	90-071-20	4	HHCS, 3/8-16 X 2 GR 5 ZN	
50	90-071-45	2	HHCS, 3/8-16 X 4-1/2 FLT GR5 ZN	
51	90-074-05	2	SSS, 3/8-16 X 1/2 CUP PT, BLACK OXIDE	
52	90-074-07	2	SSS, 3/8-16 X 3/4 CUP PT	
53	90-075-01	18	NUT, 3/8-16 HEX GR 5 ZN	
54	90-075-52	18	WASHER, 3/8 SPLIT RING	
55	90-075-53	32	WASHER, 3/8 FLAT	
56	90-075-54	4	WASHER, 3/8 AN	
57	90-078-60	1	ADAPTER, 3/8 NPT-M X 8 JIC-M - 45 DEG	
58	90-091-41	2	HHCS, 1/2-13 X 4 FULL TRD GRADE 8	
59	90-095-01	2	NUT, 1/2"-13 HEX GRADE 8	
60	90-095-52	2	WASHER, 1/2 FLAT	
61	90-098-14	1	Nipple, 1/2" Close, PVC,	
62	90-108-25	4	HHCS, M8-1.25 X 25MM DIN 933 GR8.8 ZN	
63	90-135-03	2	GROMMET, 1 3/4" ID X 2" HOLE X 1/4" THK	
64	910-3/4-1/2-FF-S	1	ADAPTER, 3/4" NPT-M X 1/2" NPT-M	
65	910-8-10-C50X-S	1	ELBOW, -8 M JIC (3/4"-16) X -10 M ORB (7/8"-14)	
66	910-16-12-C50X-S	1	ADAPTER, -12 MORB X -16 MJIC 90 DEGREE ELBOW	
67	921-SP0003-RT	1	TANK, 3 GALLON	
68	931-561CB025	7	CLIP, PLASTIC LOOM TO FRAME 1/2"	
69	931-561CB100	7	CLIP, PLASTIC LOOM TO FRAME 1"	
70	940-35608	1	RAIN CAP, 1-1/4" EXHAUST	

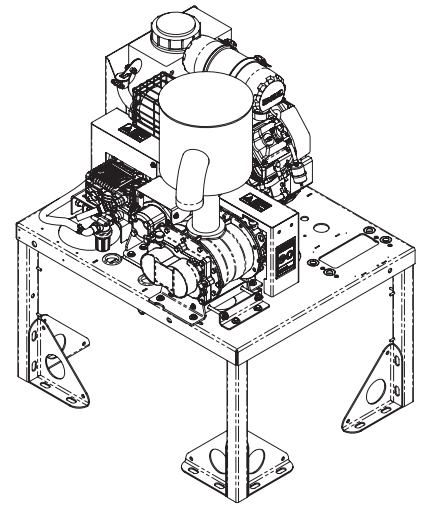

		E.H. WACHS Utility Products 600 Knightbridge Parkway Lincolnshire, IL 60069 www.ehwachs.com	
TITLE: POWERPACK, 27 HP GAS - NO CTRLS		DRAWN BY: HM	APPROVED BY: RAW
DATE: 12/4/2017	DATE: 1/12/2018	SHEET: 6 OF 6	SCALE: 1:8
PROJECT: 999-0235-0000	REV: D	77-230-03	

NOTES:

1. MATERIAL PER COMPONENT
2. FINISH PER COMPONENT
3. KIT REQUIRES OTHER COMPONENTS / SYSTEMS TO FUNCTION
4. IF STORING OR TRANSPORTING, PACKAGE AND SECURE LOOSE COMPONENTS AND HARDWARE
5. SEE HIGHER LEVEL ASSEMBLY FOR SCHEMATICS AND INTERFACES
6. APPROX WEIGHT: 670.575 LB

REVISION HISTORY			
REV.	DESCRIPTION	DATE	APP.
A	NEW RELEASE: ECD 3784	9/20/2019	MMW

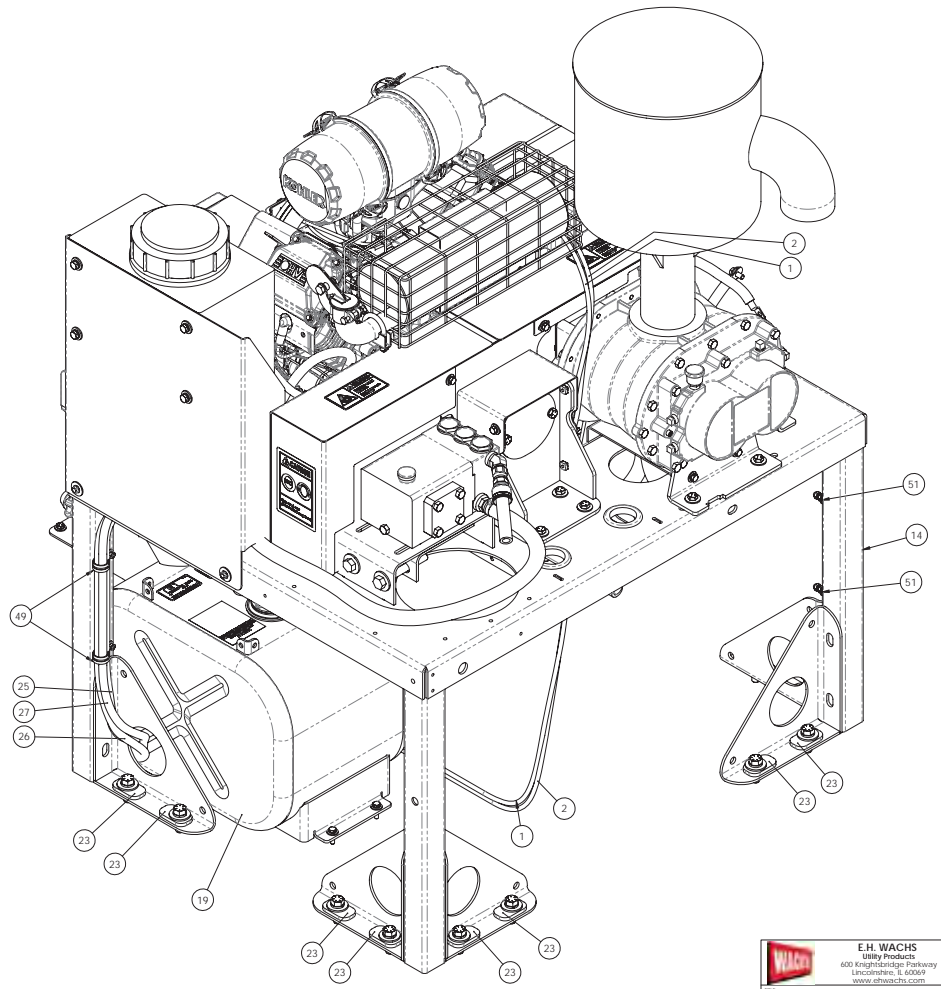
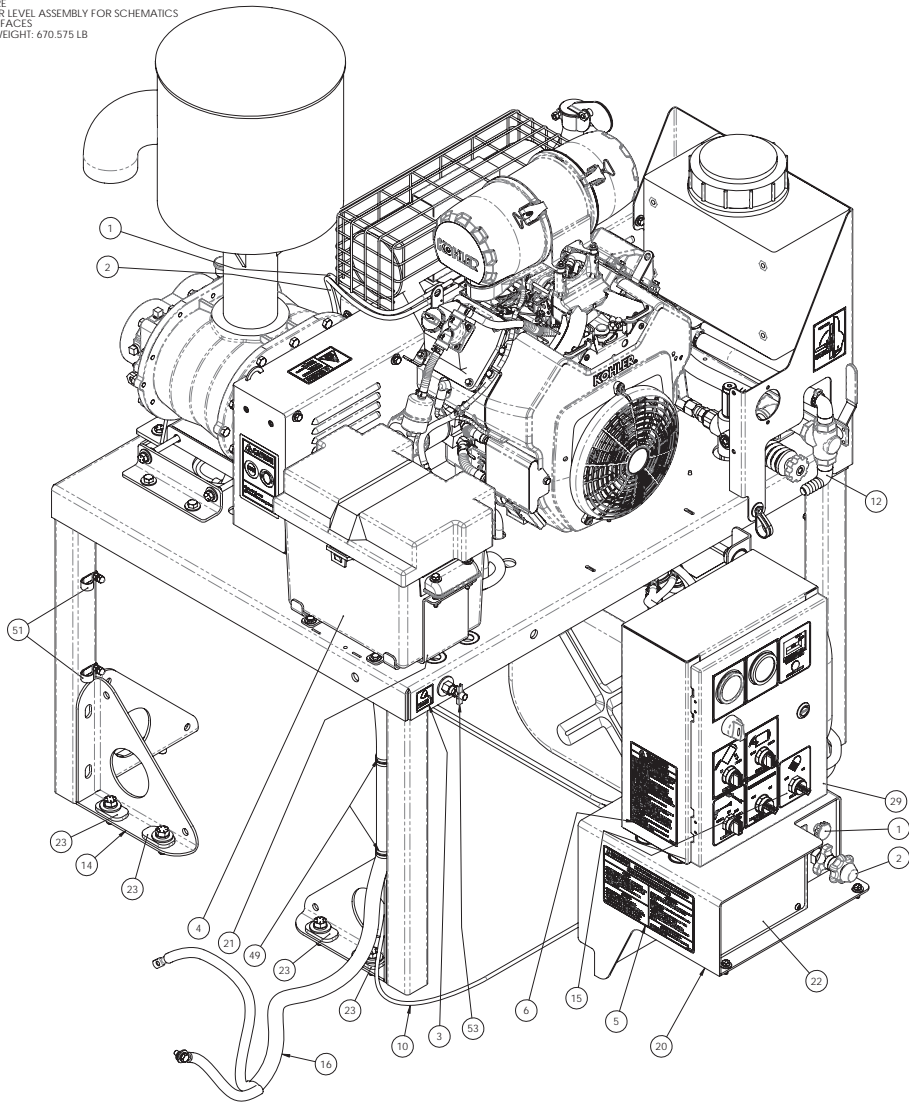

E.H. WACHS
 Utility Products
 600 Knightbridge Parkway
 Lincolnshire, IL 60069
 www.ehwachs.com

		KIT, GAS SKID POWER PACK - NO HYDRAULICS	
CONSULTANT RJ	APPROVED BY MMW	SCALE 1:4	SHEET 1 OF 7
DATE 4/23/2019	DATE 9/20/2019	REV. A	
PROPOSED AND CHECKED FOR CONFORMANCE TO THE REQUIREMENTS OF THE NATIONAL FIRE PROTECTION ASSOCIATION (NFPA) 704 HAZARDOUS MATERIALS HAZARD INDEX (HM) AND AMERICAN SOCIETY OF MECHANICAL ENGINEERS (ASME) SECTION VIII DIVISION 1.		77-230-12	

ITEM NO.	PART NUMBER	DESCRIPTION	QTY.	ESTIMATE LENGTH
1	17-064-01	CABLE, 9' CHOKE	1	
2	17-065-01	THROTTLE CABLE X 10'	1	
3	59-131-00	LABEL, CORROSION PROTECTION	1	
4	67-051-00	CASE, BATTERY	1	
5	67-112-00	LABEL, MAINTENANCE SCHEDULE	1	
6	67-117-00	LABEL, SAFETY PRECAUTIONS	1	
7	68-158-04	HOSE CLAMP, CRIMP 11.5-14.0MM	3	
8	68-158-17	HOSE CLAMP, CRIMP 9.8-12.3 MM	1	
9	68-159-25	HOSE, 1/4" FUEL- SAE 30R9/CARB	1	(43')
10	68-171-01	TUBING, 1/4" VACUUM RATED NYLON	2	(47'), (57')
11	68-172-13	ADAPTER, 1/4" PLUG-IN X 1/4" PTC 90	2	
12	68-243-30	ELBOW, 3/4" NPT-M X 3/4" HOSE BARB - NYLON	1	
13	77-064-01	ASSEMBLY, INLET ELBOW	1	
14	77-230-02	POWERPACK, 27 HP GAS - NO HYD/CTRLS	1	
15	77-242-01	ISOLATION MOUNT, 35 LB	5	
16	77-248-00	HARNESS, HPU TO BATTERY	1	
17	77-267-05	LABEL, THROTTLE	1	
18	77-267-06	LABEL, CHOKE	1	
19	77-282-20	GASOLINE FUEL TANK, 10 GALLON ALUMINUM	1	
20	77-290-10	WELDMENT, CONTROL MOUNT	1	
21	77-290-14	BATTERY HOLD DOWN BRACKET	2	
22	77-290-39	CONTROL PANEL PLATE	1	
23	77-290-40	CLAMPING WASHER	12	
24	77-313-50	BATTERY, DEEP CYCLE 12V	1	
25	77-520-03-14	WIRE HARNESS, GAS ENGINE GRAND VMT	1	
26	77-520-03-26	WIRE HARNESS, POWER TO CTL BOX	1	
27	77-520-03-27	WIRE HARNESS, GND TO CTL BOX - GAS	1	
28	77-520-03-31	WIRE HARNESS, BATTERY TO ENGINE	1	
29	77-520-20	CONTROL CABINET, VMT GAS	1	
30	90-051-07	HHCS, 1/4-20 X 3/4 GRADE 5 ZN	4	
31	90-051-10	HHCS, 1/4-20 X 1	8	
32	90-051-22	HHCS, 1/4-20 X 2-1/4	4	
33	90-052-05	BHCS, 1/4-20 X 1/2	4	
34	90-055-01	NUT, 1/4-20 HEX	14	
35	90-055-18	NUT, 1/4-20 ACORN	8	
36	90-055-52	WASHER, 1/4 SPLIT RING	24	
37	90-055-53	WASHER, FLAT, 1/4	22	
38	90-061-07	HHCS, 5/16-18 X 3/4	3	
39	90-065-51	WASHER, 5/16 SPLIT RING	3	
40	90-065-52	WASHER, 5/16 FLAT	3	
41	90-071-10	HHCS, 3/8-16 X 1	2	
42	90-071-20	HHCS, 3/8-16 X 2 GR 5 ZN	5	
43	90-075-01	NUT, 3/8-16 HEX GR 5 ZN	5	
44	90-075-52	WASHER, 3/8 SPLIT RING	7	
45	90-075-53	WASHER, 3/8 FLAT	12	
46	90-091-15	HHCS, 1/2-13 X 1-1/2 GRADE 8 ZN	12	
47	90-095-52	WASHER, 1/2 FLAT	13	
48	90-095-58	WASHER, 1/2 SPLIT RING	12	
49	90-903-10	CUSHIONED LOOP CLAMP, 1"	5	
50	90-903-50	CUSHIONED LOOP CLAMP, 1/2"	3	
51	90-903-75	CUSHIONED LOOP CLAMP, 3/4"	4	
52	90-1062-58	HHFS, 1/4-20 x 5/8" GR5 ZN	3	
53	90-4921K44	FITTING, DRAIN, 1/4" NPT	1	
54	90-5111K204	BULKHEAD FITTING, 1/4" PTC X 1/4" NPTF	1	
55	90-5779K693	FITTING, 1/4" TUBE STEM TEE	1	
56	941-CARB	VAPOR CANISTER ASSEMBLY-CARB/EPA	1	

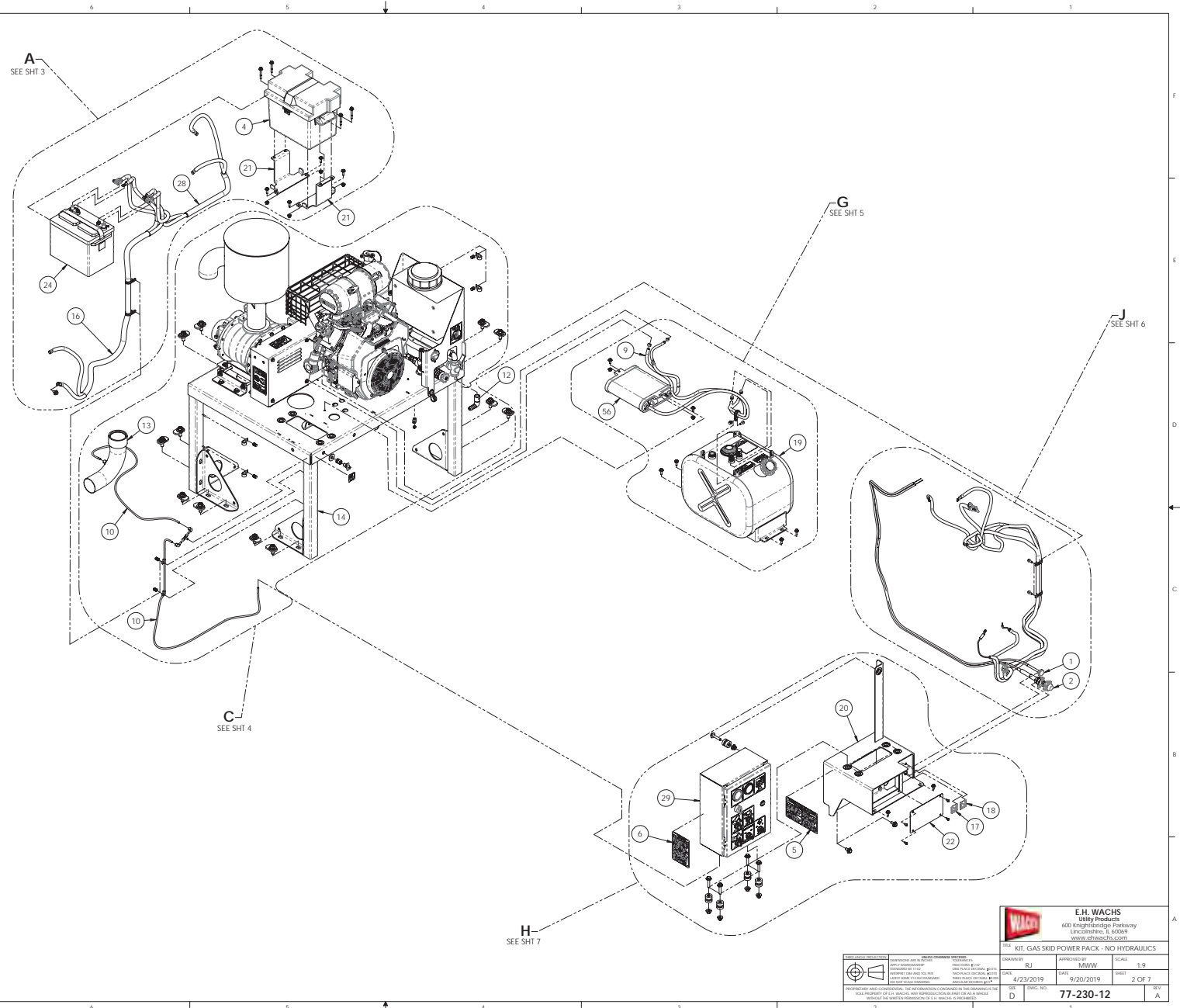

		E.H. WACHS Utility Products 600 Knightbridge Parkway Lincolnshire, IL 60069 www.ehwachs.com	
		KIT, GAS SKID POWER PACK - NO HYDRAULICS	SCALE 1:1
DRAWN BY RJ	APPROVED BY BMW	DATE 4/23/2019	SHEET 2 OF 7
DESIGNED BY RJ	DATE 4/23/2019	REV. NO. 1	REV. A
77-230-12			

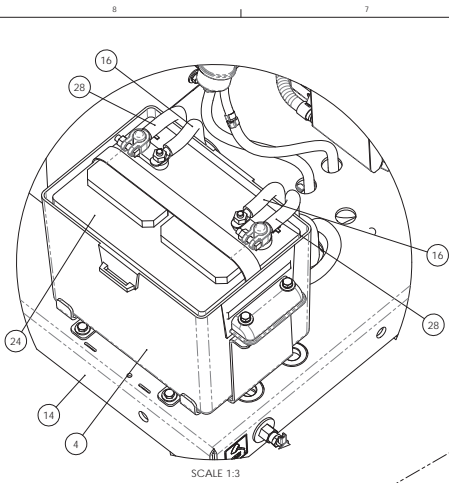

SCALE 1:3

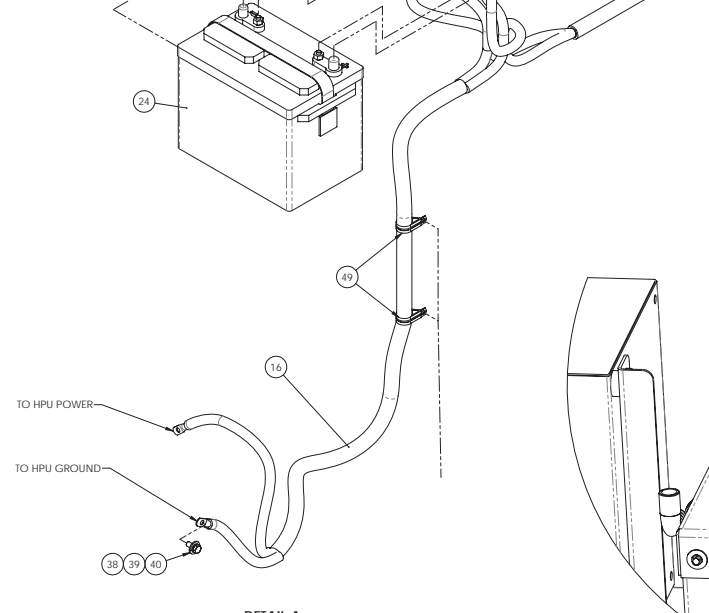

DETAIL A

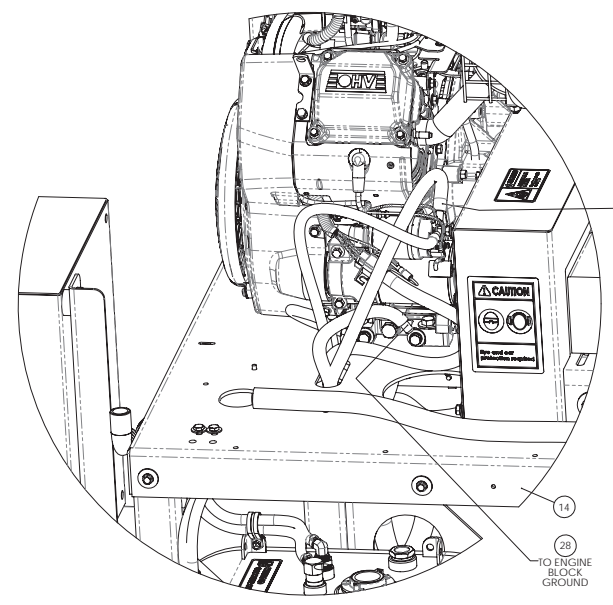
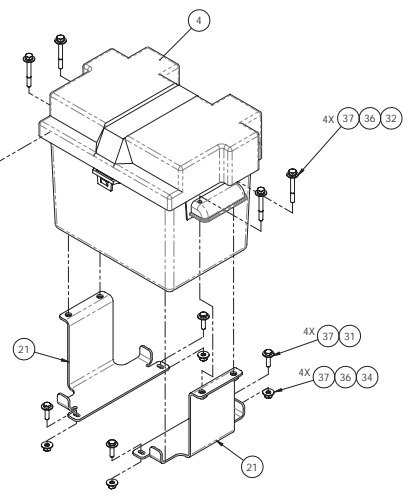

SCALE 1:3

ITEMS REMOVED FOR CLARITY

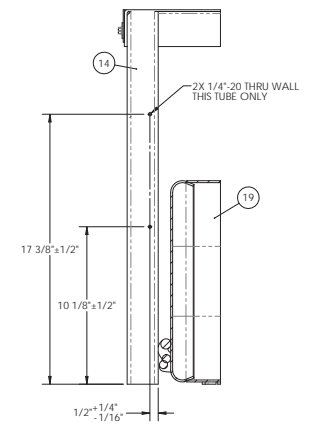

SECTION K-K

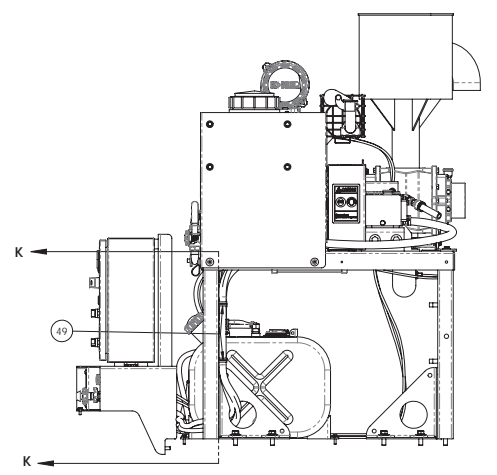

SCALE 1:8

		E.H. WACHS Utility Products 600 Knightbridge Parkway Lincolnshire, IL 60069 www.ehwachs.com	
KIT, GAS SKID POWER PACK - NO HYDRAULICS		DRAWN BY: RJ	APPROVED BY: RMW
DATE: 4/23/2019	DATE: 9/20/2019	SCALE: 1:4	SHEET: 3 OF 7
REV: D	REV: 10	77-230-12	REV: A

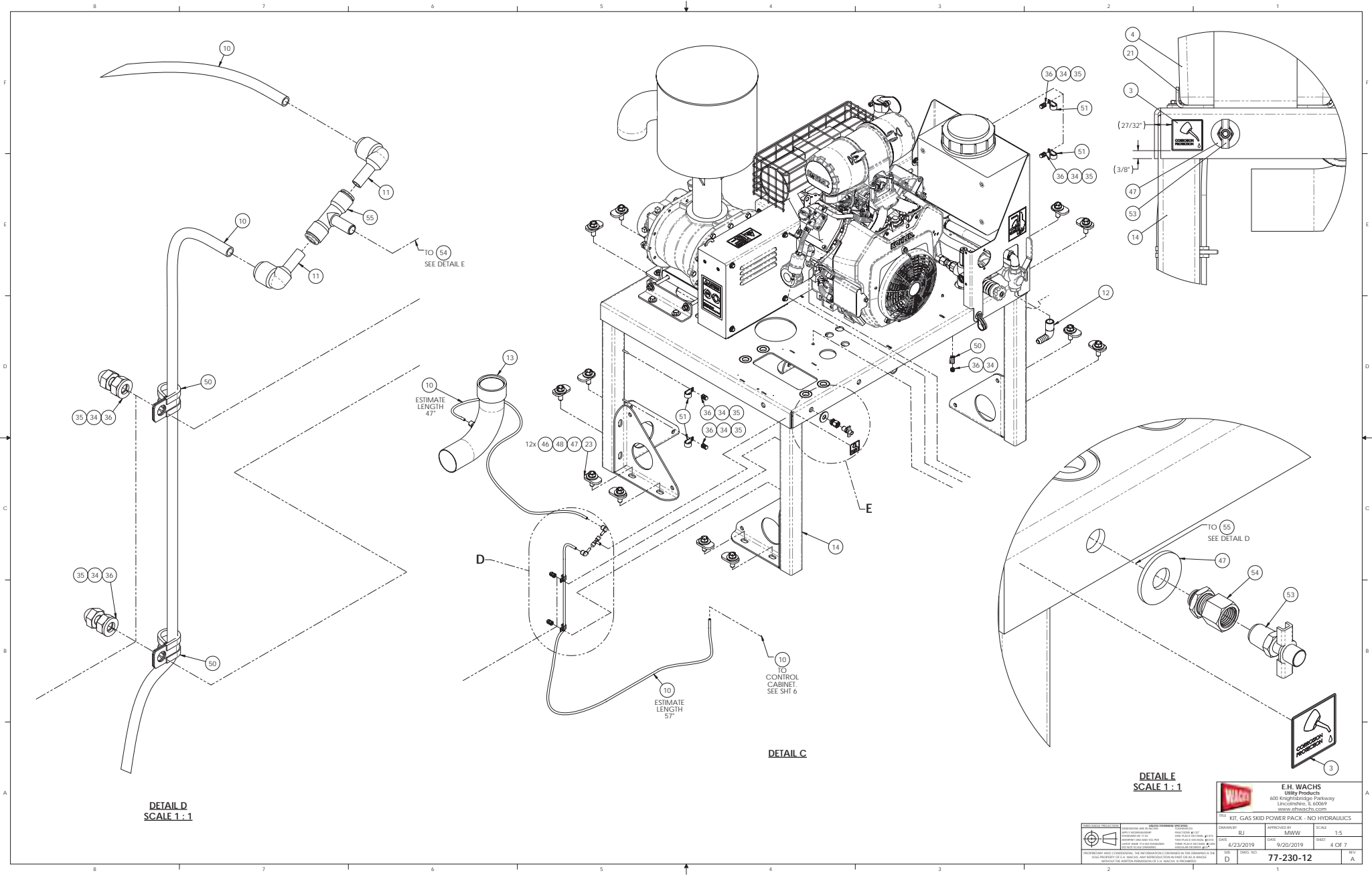

DETAIL D
SCALE 1 : 1

DETAIL C

DETAIL E
SCALE 1 : 1



		E.H. WACHS Utility Products 600 Knightbridge Parkway Lincolnshire, IL 60069 www.ehwachs.com	
KIT, GAS SKID POWER PACK - NO HYDRAULICS			
DRAWN BY RJ	APPROVED BY BMW	SCALE 1:5	SHEET 4 OF 7
DATE 4/23/2019	DATE 9/20/2019	REV. A	
TITLE D		PART NO. 77-230-12	

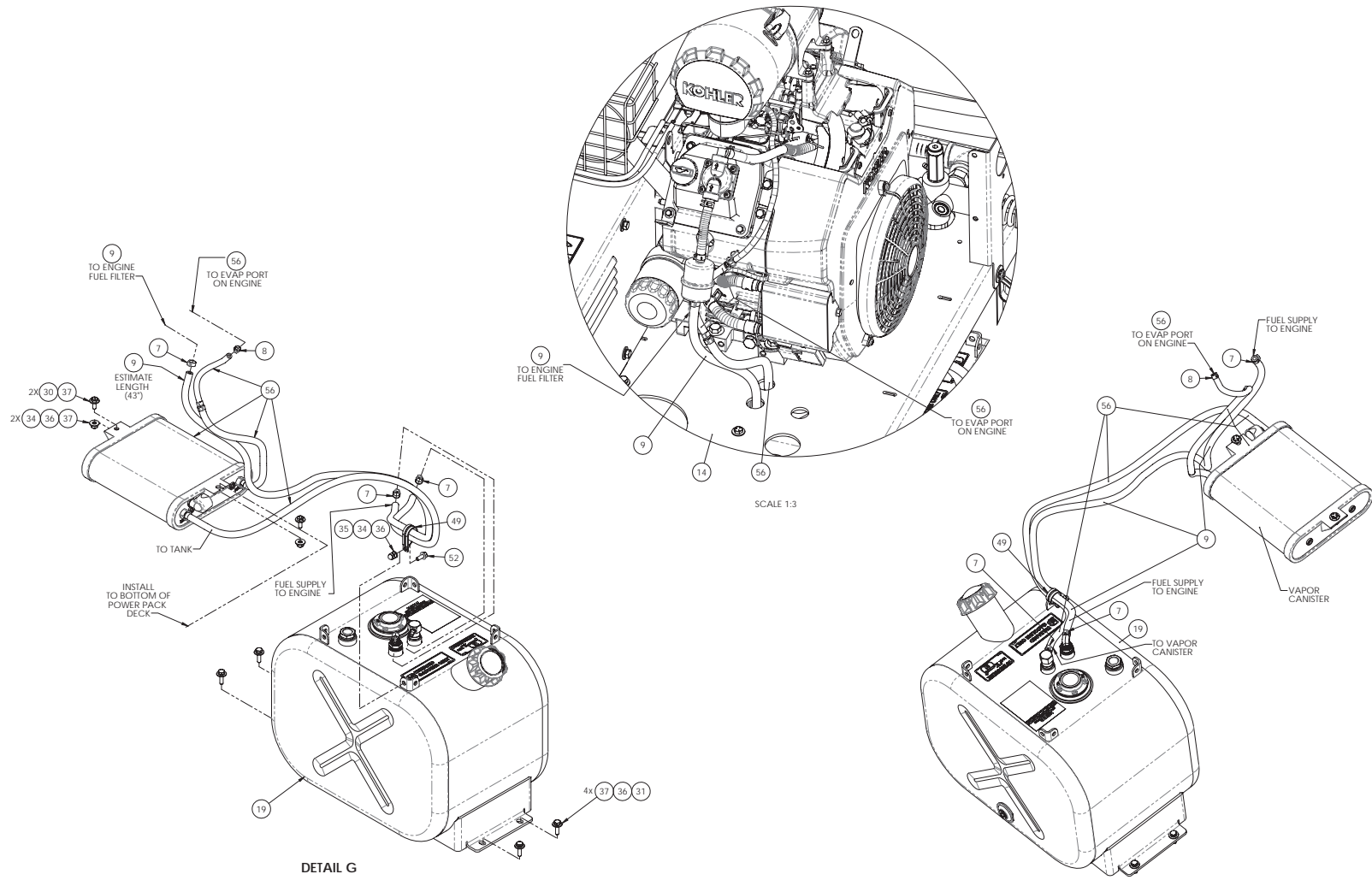

E.H. WACHS
 Utility Products
 600 Knightbridge Parkway
 Lincolnshire, IL 60069
 www.ehwachs.com

		KIT, GAS SKID POWER PACK - NO HYDRAULICS	
DRAWN BY RJ	CHECKED BY RJ	APPROVED BY RW	SCALE 1:4
DATE 4/23/2019	DATE 9/20/2019	SHEET 5 OF 7	REV. A
PROPOSED AND CHECKED: THE REPRESENTATION CONTAINED ON THIS DRAWING IS THE PROPERTY OF E.H. WACHS. ANY REPRODUCTION OR TRANSMISSION OF THIS DRAWING WITHOUT THE WRITTEN PERMISSION OF E.H. WACHS IS PROHIBITED.		77-230-12	

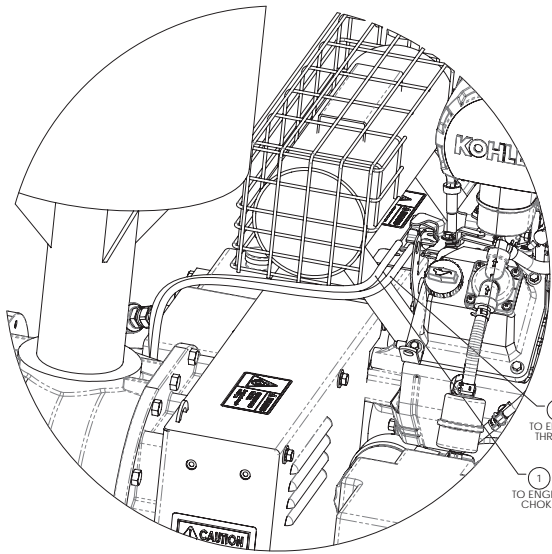

CUT CHOKE AND THROTTLE CABLES TO FIT

1 TO ENGINE CHOKE

2 TO ENGINE THROTTLE

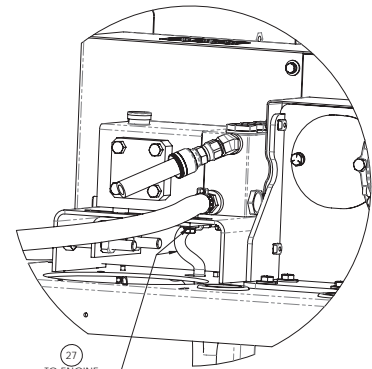

27 TO ENGINE WATER PUMP GROUND

SCALE 1:3

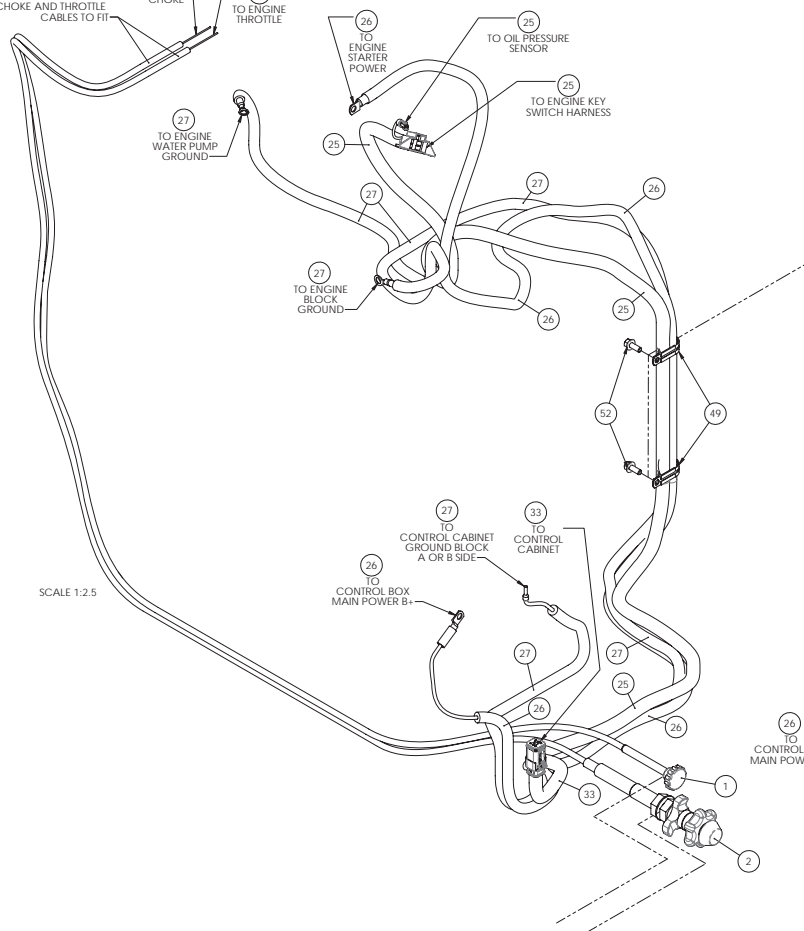

SCALE 1:2.5

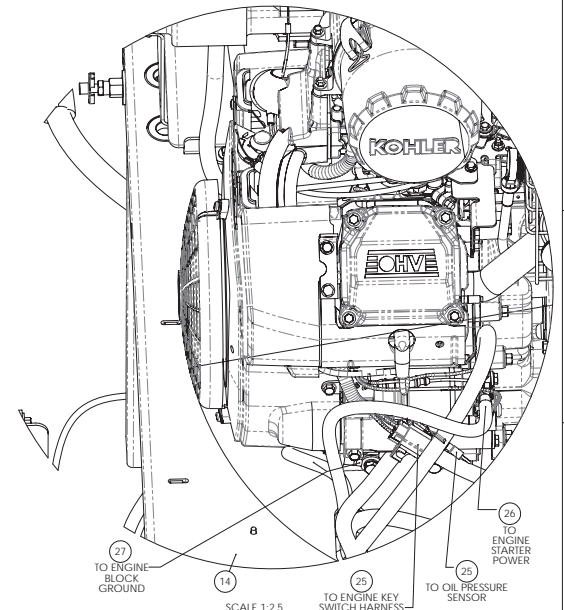

26 TO ENGINE STARTER POWER

25 TO OIL PRESSURE SENSOR

25 TO ENGINE KEY SWITCH HARNESS

27 TO ENGINE BLOCK GROUND

14

SCALE 1:2.5

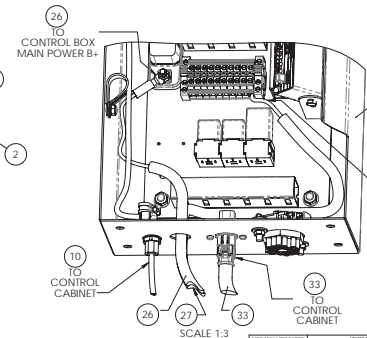

26 TO CONTROL BOX MAIN POWER B+

27 TO CONTROL CABINET GROUND BLOCK A OR B SIDE

SCALE 1:3

DETAIL J

		E.H. WACHS Utility Products 600 Knightbridge Parkway Lincolnshire, IL 60069 www.ehwachscorp.com	
KIT, GAS SKID POWER PACK - NO HYDRAULICS		DATE: 4/23/2019	SCALE: 1:3
DRAWN BY: RJ	APPROVED BY: BAW	DATE: 9/20/2019	SHEET: 6 OF 7
TITLE: D	REV: 10	PART NO: 77-230-12	REV: A

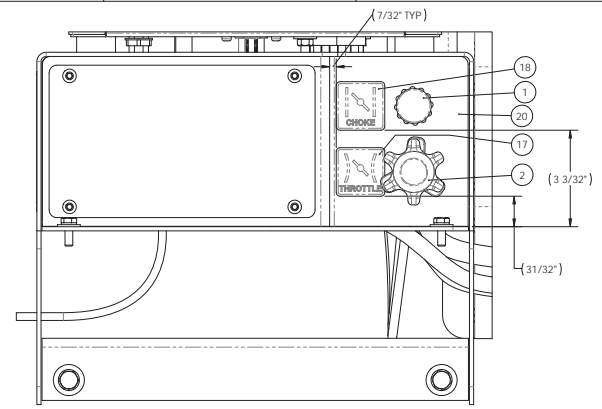
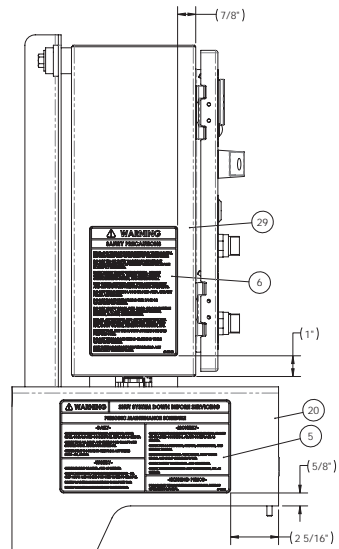

SCALE 1:2

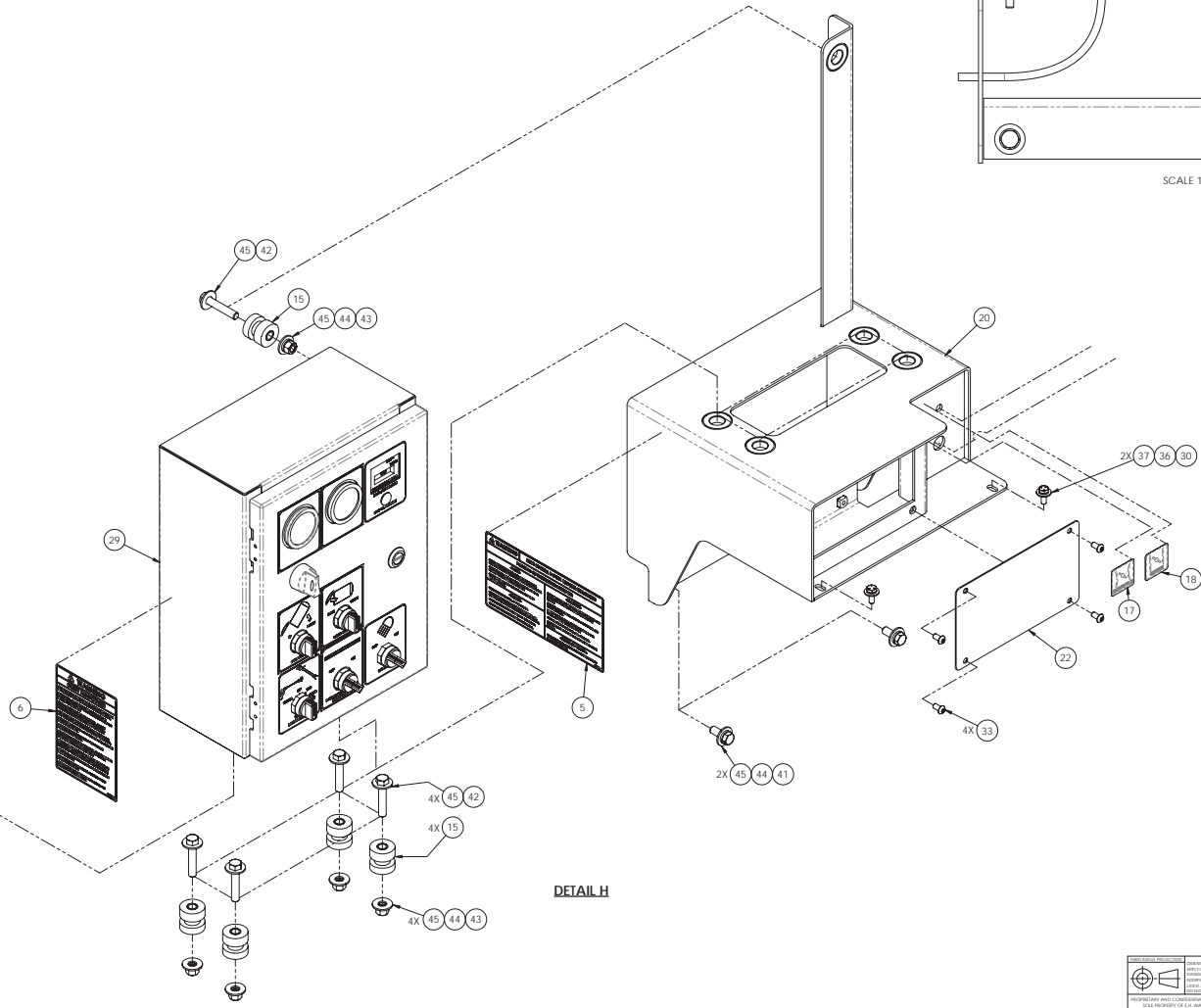

DETAIL H

TO 10
SEE SHFT 4

E.H. WACHS
Utility Products
600 Knightbridge Parkway
Lincolnshire, IL 60069
www.ehwachs.com

		KIT, GAS SKID POWER PACK - NO HYDRAULICS	
DRAWN BY RJ	CHECKED BY 	APPROVED BY BMW	SCALE 1:3
DATE 4/23/2019	DATE 	DATE 9/20/2019	SHEET 7 OF 7
USE D	2019, 20	77-230-12	
<small> PROPORTION AND DIMENSIONS ARE APPROXIMATE. THE INFORMATION CONTAINED IN THIS DRAWING IS THE PROPERTY OF E.H. WACHS. ANY REPRODUCTION OR TRANSMISSION OF THIS DRAWING WITHOUT THE WRITTEN PERMISSION OF E.H. WACHS IS PROHIBITED. </small>		REV. A	

NOTES:

1. MATERIAL: PER COMPONENT
2. FINISH: PER COMPONENT
3. SEE WELDMENTS 77-431-01-00 AND 77-431-03-10 FOR DECAL 77-160-90 PLACEMENT
4. REFER TO SCHEMATIC SHEET 4 REGARDING HOSE ROUTING DETAILS
5. USE THREAD SEALANT ON ALL FASTENERS
6. LIBERALLY APPLY GREASE TO ALL FRICTION LOCATIONS
7. APPROX WEIGHT: 1100 LB

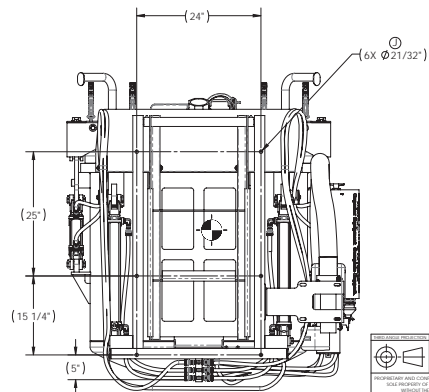
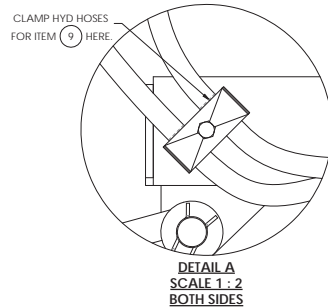
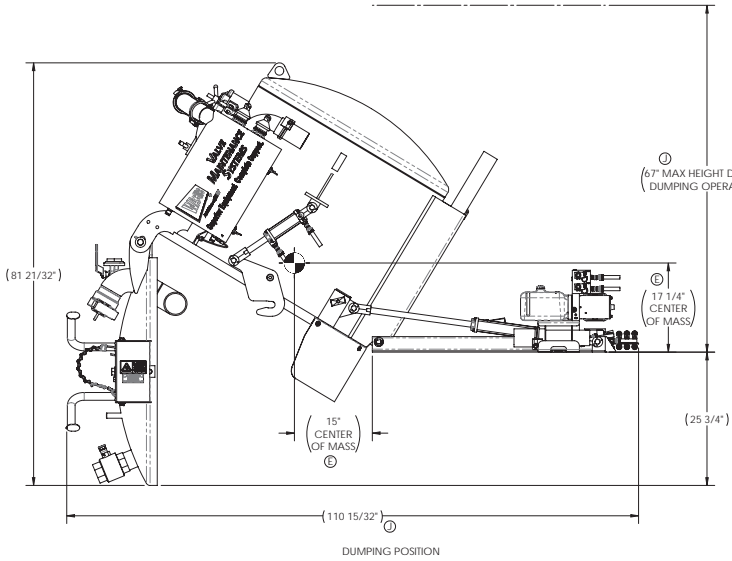
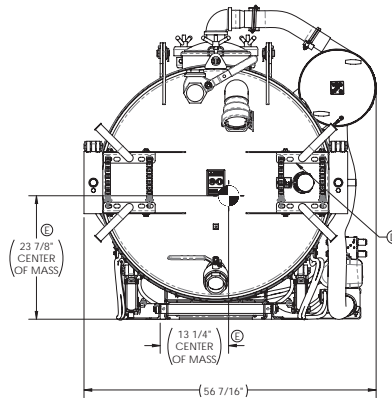
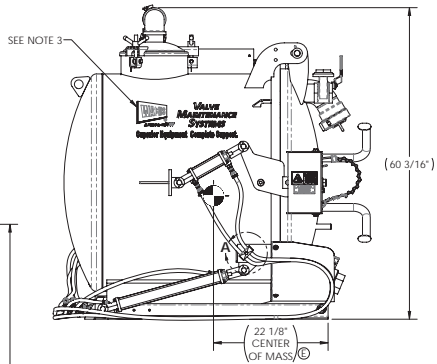
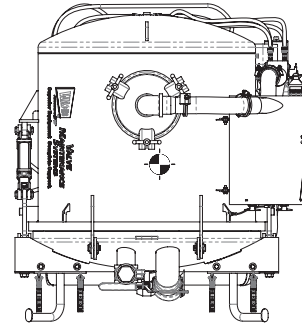
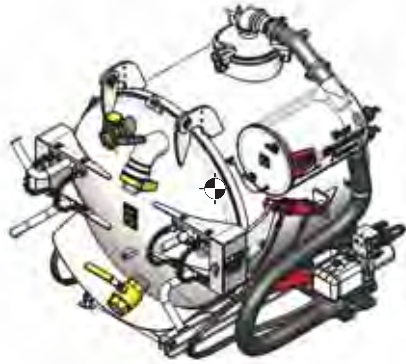
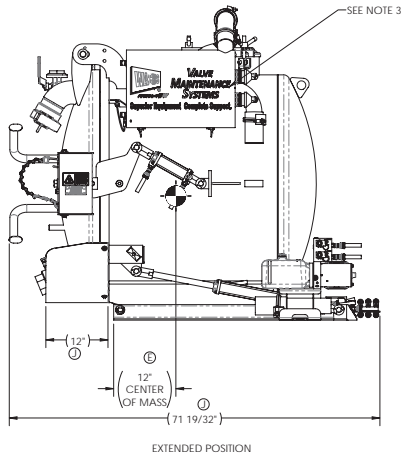

REVISION HISTORY			
REV.	DESCRIPTION	DATE	APP.
A	CHANGED FILTER ASSEMBLY	8/24/2011	GJD
B	UPDATE ASSEMBLY DRAWING TO REFLECT EXPLoded VIEWS HYDRAULIC SCHEMATIC	5/5/2014	JMB
C	ECCO 3000	11/16/2015	JMB
D	MOVE 48-022-31, 48-022-52 TO HOSES ECCO 3011	12/2/2015	JMB
E	ADD CENTER OF MASS AND ASSEMBLY WEIGHT ECCO 3000	1/6/2016	JMB
F	UPDATE 77-431-01-00, ECCO 3004	1/21/2016	JMB
G	ADD 1 GREASE FITTING & MISC. ITEMS PER ECCO 2001	11/30/2017	HM
H	WAS 48-109-02, ECCO 3000	2/5/2018	BC
J	ADD CHUTE (7) LABELS HYD HOSE CLAMP AND BANGLES, UPDATED REFERENCE DIMENSIONS CHANGES PER ECCO 3004	4/19/2019	HM

		E.H. WACHS Utility Products 600 Knightbridge Parkway Lincolnshire, IL 60069 www.ehwachs.com	
TITLE: ASSEMBLY, 250 GAL SPOILS TANK			
DESIGNED BY: DAL	APPROVED BY: SMW	SCALE: 1:12	
DATE: 2/21/09	DATE: 8/31/09	SHEET: 1 OF 4	
SIZE: D	PROJ. NO: 77-431-02-00	REV.:	J

ITEM	PART NUMBER	QTY	DESCRIPTION	LENGTH
1	67-093-02	1	CLAMP, 4" BANDLOCK	
2	67-093-03	1	GASKET, 4" BANDLOCK COUPLER	
3	67-093-06	1	PLUG, 4" MALE	
4	68-022-51	2	WELDMENT, RH BRACKET	
5	68-022-52	2	WELDMENT, LH BRACKET	
6	68-023-01	2	WELDMENT, YOKE	
7	68-024-00	2	CAM, DOOR	
8	68-034-12	1	ELBOW, 3" NPT	
9	68-103-00	2	HYDRAULIC CYLINDER, 4" STROKE	
10	68-108-01	1	SEAL, DUMP DOOR (1" X 1-7/16" X 11'6")	
11	68-113-00	1	SITE EYE GLASS AND O-RING	
12	68-114-01	1	ALUMINUM CARTRIDGE BODY	
13	68-114-00	1	CARTIRDRGE, FLOW DIVIDER	
14	68-121-01	3	NUT, BULKHEAD LOCK	
15	68-126-01	2	DOOR HINGE, CLAMP COLLAR 25mm	
16	68-132-00	1	HYDRAULIC POWER UNIT - 12 VDC	
17	68-134-00	1	NIPPLE, 3" NPT X 3" COMBINATION HOSE	
18	68-153-10	1	SCREEN, 3.5625 x .20 MESH SS	
19	68-153-00	1	VALVE, 3" BALL	
20	68-158-57	4	HOSE CLAMP, 3" SPIRAL, CLOCKWISE	
21	68-160-03	1	HOSE, 3" VACUUM BLACK	1.5'
22	68-160-03	1	HOSE, 3" VACUUM BLACK	6.75'
23	77-015-01	2	HYDRAULIC CYLINDER, 18" STROKE	
24	77-072-50-01	1	WELDMENT, BALL CAGE	
25	77-072-50-02	1	WELDMENT, MODIFIED SHUT OFF LID	
26	77-072-50-04	1	6" STAINLESS STEEL FLOAT BALL	
27	77-072-50-05	1	3" BUNA BALL SEAT	
28	77-072-50-06	1	CLAMP FOR 3" BALL SEAT	
29	77-072-50-08	3	WINGNUT, CARBON 5/8 UNC THREAD	
30	77-072-50-09	3	CLEVIS PIN	
31	77-072-50-11	1	BUNA GASKET, 12" LID	
32	77-072-50-13	3	EYEBOLT 5/8 UNC X 5"	
33	77-074-00	1	WELDMENT, RAIL	
34	77-075-18	1	HPU MOUNT	
35	77-075-20	1	CHUTE	
36	77-075-00	1	SUPPORT FRAME, TANK	
37	77-108-01	1	WELDMENT, 42" DUMP DOOR	
38	77-160-05	1	LABEL, EYE AND EAR PROTECTION	
39	77-160-10	2	LABEL, PINCH POINT	
40	77-160-25	2	LABEL, HEAVY DOOR	
41	77-180-00	1	BAR, PIVOT	
42	77-209-02	1	CLAMP, 3" 15' DOOR	
43	77-241-00	2	SHSB, 1 X 1-3/4" ZINC PLATED	
44	77-280-63	1	VALVE, 3" GATE	
45	77-290-41	1	LABEL, 250 GAL TANK SPOILS WEIGHT	
46	77-290-45	1	LABEL, SPOILS TANK LEVEL 60%	
47	77-431-01-00	1	TANK WELDMENT, 200 GAL W/EXTERNAL FILTER	
48	77-431-03-00	1	FILTER ASSEMBLY	
49	77-620-00-01	2	19 1/2" HOSE ASSEMBLY -06 FJ X -06 FJ X -06 HOSE	
50	77-620-00-02	2	41 1/2" HOSE ASSEMBLY -06 FJ X -06 FJ X -06 HOSE	
51	77-631-00-01	2	99 1/2" HOSE ASSEMBLY -06 FJ X -06 FJ X -06 HOSE	
52	77-631-00-02	1	126 1/2" HOSE ASSEMBLY -06 FJ X -06 FJ X -06 HOSE	
53	77-631-00-07	1	90 1/2" HOSE ASSEMBLY -06 FJ X -06 FJ X -06 HOSE	
54	77-631-00-08	4	34 1/2" HOSE ASSEMBLY -06 FJ X -06 FJ X -06 HOSE	
55	79-102-11	4	SUCTION HOSE BUNGEE	
56	90-016-91	3	PIN, 3/16 X 1-1/2 COTTER SS	
57	90-046-91	2	PIN, 3/16 X 2 COTTER	
58	90-046-91	2	PIN, 3/16 X 2 COTTER	
59	90-051-05	4	HHCS, 1/4-20 X 1/2	
60	90-051-10	1	HHCS, 1/4-20 X 1	
61	90-051-20	2	HHCS, 1/4-20 X 2 GRADE 5 Zn	
62	90-054-05	2	SSS, 1/4-20 X 1/2 CUP PT	
63	90-055-01	3	NUT, 1/4-20 HEX	
64	90-055-18	1	NUT, 1/4-20 ACORN	
65	90-055-52	7	WASHER, 1/4 SPLIT RING	
66	90-055-53	6	WASHER, FLAT, 1/4	
67	90-055-57	4	WASHER, 1/4 x 1 OD FENDER 18-8SS	
68	90-071-12	2	HHCS, 3/8-16 X 1-1/4 GRADE 5	
69	90-075-01	2	NUT, 3/8-16 HEX GR 5 Zn	
70	90-075-52	4	WASHER, 3/8 SPLIT RING	
71	90-075-53	4	WASHER, 3/8 FLAT	
72	90-091-17	8	HHCS, 1/2-13 X 1-3/4	
73	90-091-21	2	HHCS, 1/2-13 X 2	
74	90-095-01	8	NUT, 1/2-13 HEX	
75	90-095-52	16	WASHER, 1/2 FLAT	
76	90-095-58	8	WASHER, 1/2 SPLIT RING	
77	90-120-75	2	HHCS, 7/8-14 X 2-3/4 LNG	
78	90-125-51	2	WASHER, 7/8 SAE	
79	90-136-25-01	2	PIN, CLEVIS, 1X2	
80	90-171-12	3	HHCS, 3/8 X 1 1/4 SS	
81	90-175-01	3	NUT, 3/8-16 HEX SS18-8	
82	90-175-51	6	WASHER, 3/8 FLAT - SS	
83	90-175-52	3	WASHER, 3/8 SPLIT RING	
84	90-235-52	4	WASHER, 1X 2	
85	90-235-53	2	WASHER, 1X 2.5	
86	90-500-05	4	GREASE FITTING, 1/4-28 STRAIGHT	
87	910-6-8-C50X-S	4	ADAPTER, -08 ORB-M (3/4-16) X -06 JIC-M (9/16-18) 90 DEG	
88	910-6-8-F50X-S	5	ADAPTER, -08 ORB-M (3/4-16) X -06 JIC-M (9/16-18)	
89	910-6-FD0X-S	6	ADAPTER, -06 JIC-M (9/16-18) X -06 ORB-M (9/16-18)	
90	910-6-WJX-S	3	TEE, -06 JIC-M (9/16-18)	

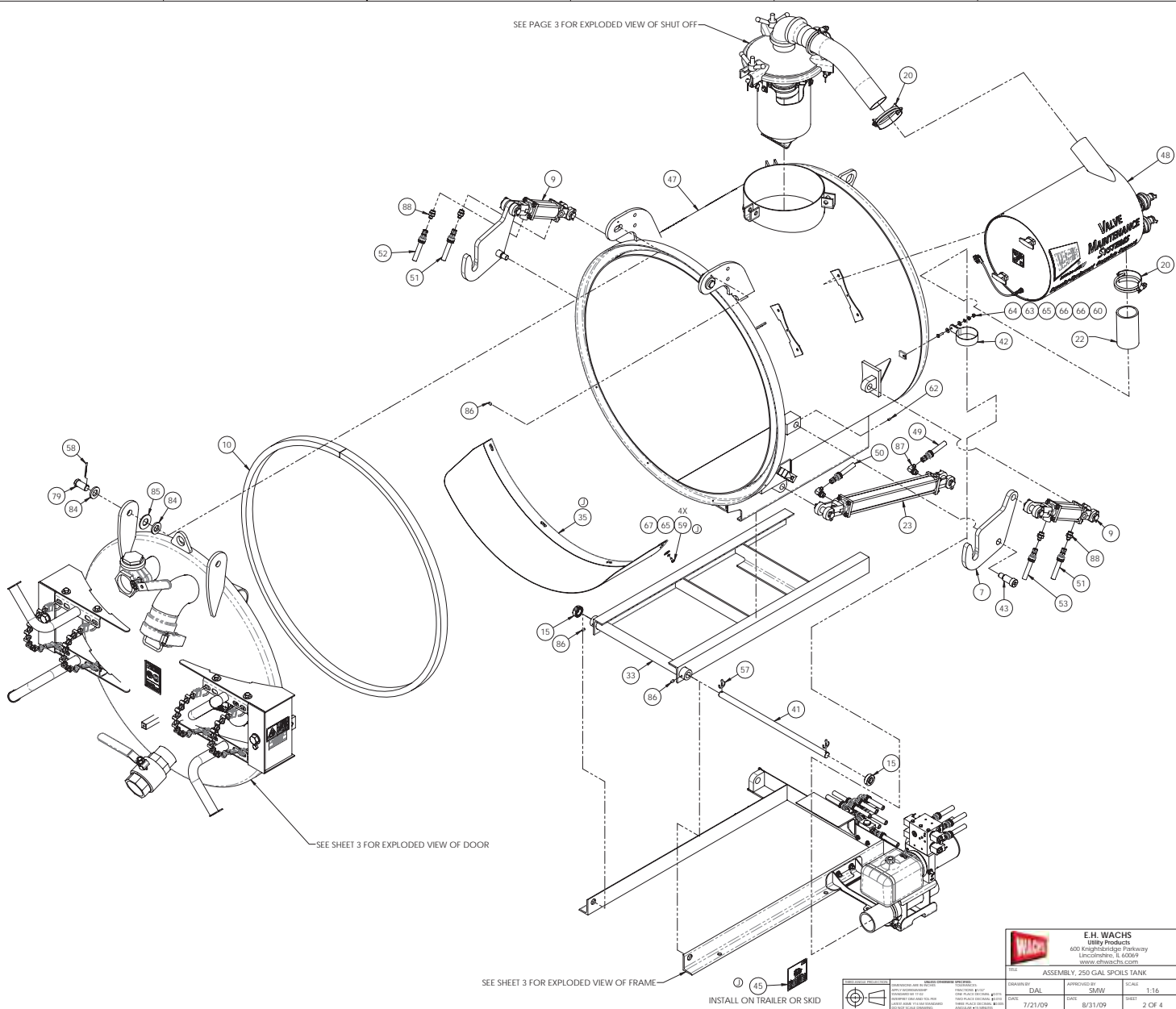

E.H. WACHS Utility Products 600 Knightbridge Parkway Lincolnshire, IL 60069 www.ehwachs.com	
TITLE: ASSEMBLY, 250 GAL SPOILS TANK	
DATE: 3/21/09	APPROVED BY: SMV
SCALE: 1:16	SHEET: 2 OF 4
REV: J	REV: J

1. THIS DRAWING IS THE PROPERTY OF E.H. WACHS. IT IS TO BE USED ONLY FOR THE PROJECT AND PURPOSE SPECIFIED HEREON. IT IS NOT TO BE REPRODUCED, COPIED, OR TRANSMITTED IN ANY FORM OR BY ANY MEANS, ELECTRONIC OR MECHANICAL, INCLUDING PHOTOCOPYING, RECORDING, OR BY ANY INFORMATION STORAGE AND RETRIEVAL SYSTEM, WITHOUT THE WRITTEN PERMISSION OF E.H. WACHS.

77-431-02-00

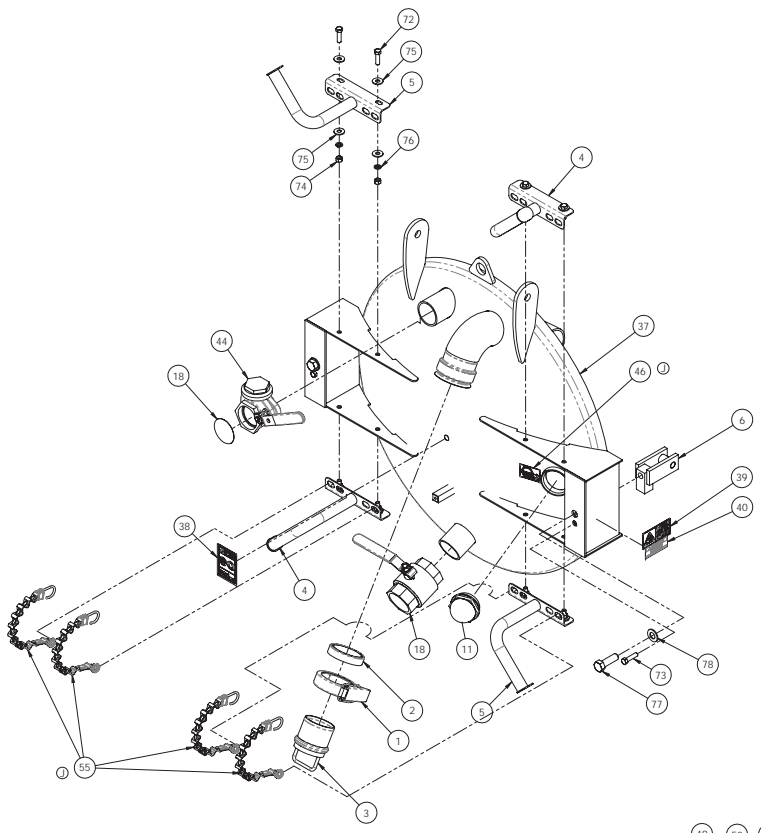

DOOR EXPLODE
SCALE 1:8
ⓐ

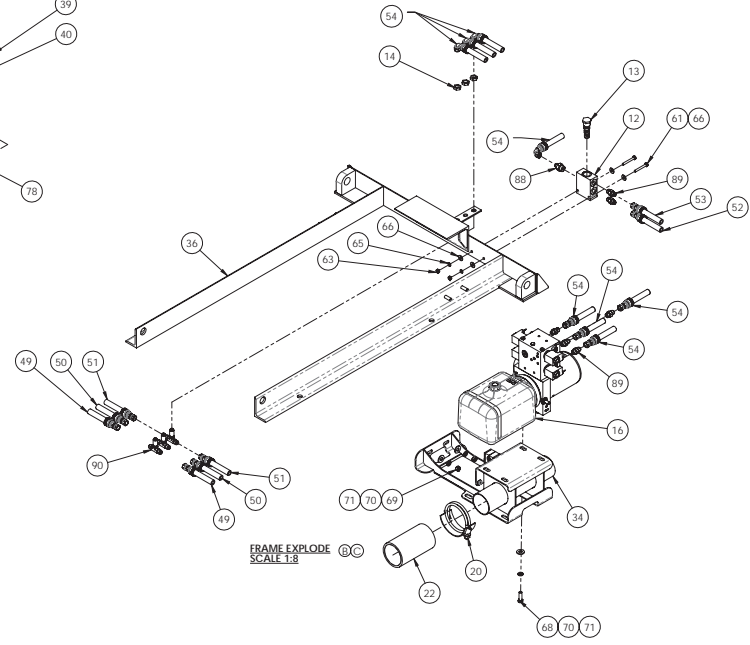

FRAME EXPLODE
SCALE 1:8
ⓐ

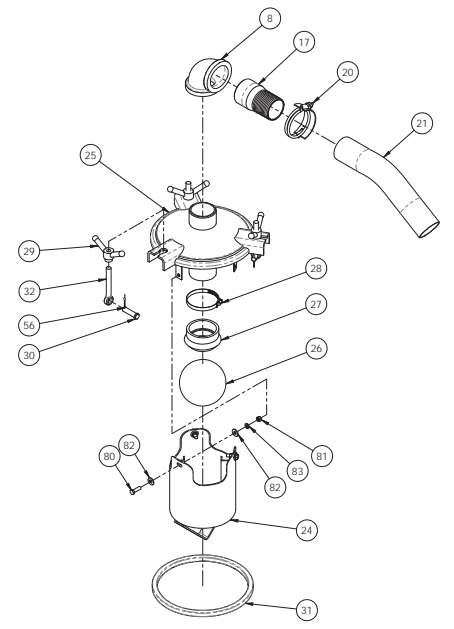

SHUT OFF EXPLODE
SCALE 1:8
ⓐ

		E.H. WACHS Utility Products 600 Knightbridge Parkway Lincolnshire, IL 60069 www.ehwachs.com	
TITLE ASSEMBLY, 250 GAL SPOILS TANK			
DRAWN BY DAL	CHECKED BY SMV	APPROVED BY SMV	SCALE 1:32
DATE 7/21/09	DATE 8/31/09	SHEET 3 OF 4	REV. J
PROPOSED AND CHECKED FOR CONFORMANCE WITH THE REQUIREMENTS OF THE NATIONAL FIRE PROTECTION ASSOCIATION (NFPA) 1847 STANDARD FOR SPOILS TANKS.		SEE 77-431-02-00	
NOT TO BE USED FOR ANY OTHER PURPOSE WITHOUT THE WRITTEN PERMISSION OF E.H. WACHS.		77-431-02-00	

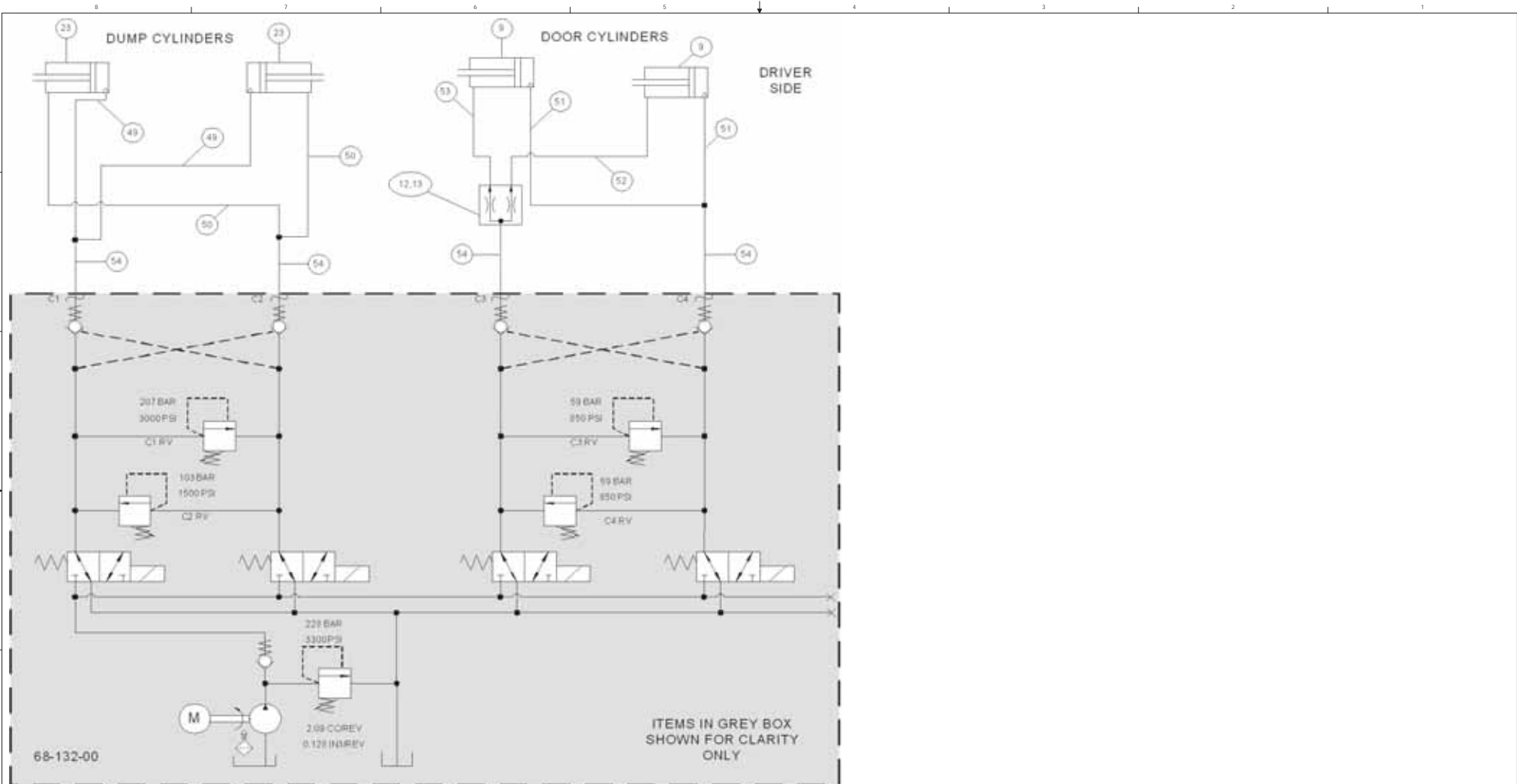

HYDRAULIC SCHEMATIC © © ©

		E.H. WACHS Utility Products 600 Knightbridge Parkway Lincolnshire, IL 60069 www.ehwachs.com	
		TITLE ASSEMBLY, 250 GAL SPOILS TANK	SCALE 1:1A
DRAWN BY DAL	APPROVED BY SMV	DATE 7/21/09	SHEET 4 OF 4
SIZE D	77-431-02-00	REV. J	

PROPORTION AND POSITION OF ALL DIMENSIONS SHALL BE AS SHOWN UNLESS OTHERWISE SPECIFIED.
 DIMENSIONS SHALL BE IN MILLIMETERS UNLESS OTHERWISE SPECIFIED.
 DIMENSIONS SHALL BE IN INCHES UNLESS OTHERWISE SPECIFIED.
 DIMENSIONS SHALL BE IN MILLIMETERS UNLESS OTHERWISE SPECIFIED.
 DIMENSIONS SHALL BE IN INCHES UNLESS OTHERWISE SPECIFIED.

- NOTES:
 1. MATERIAL: PER COMPONENT
 2. FINISH: PER COMPONENT
 3. APPROX WEIGHT: 218.778 LB

REVISION HISTORY			
REV	DESCRIPTION	DATE	APR
A	NEW RELEASE PER ECO 3784	9/20/2019	MWW

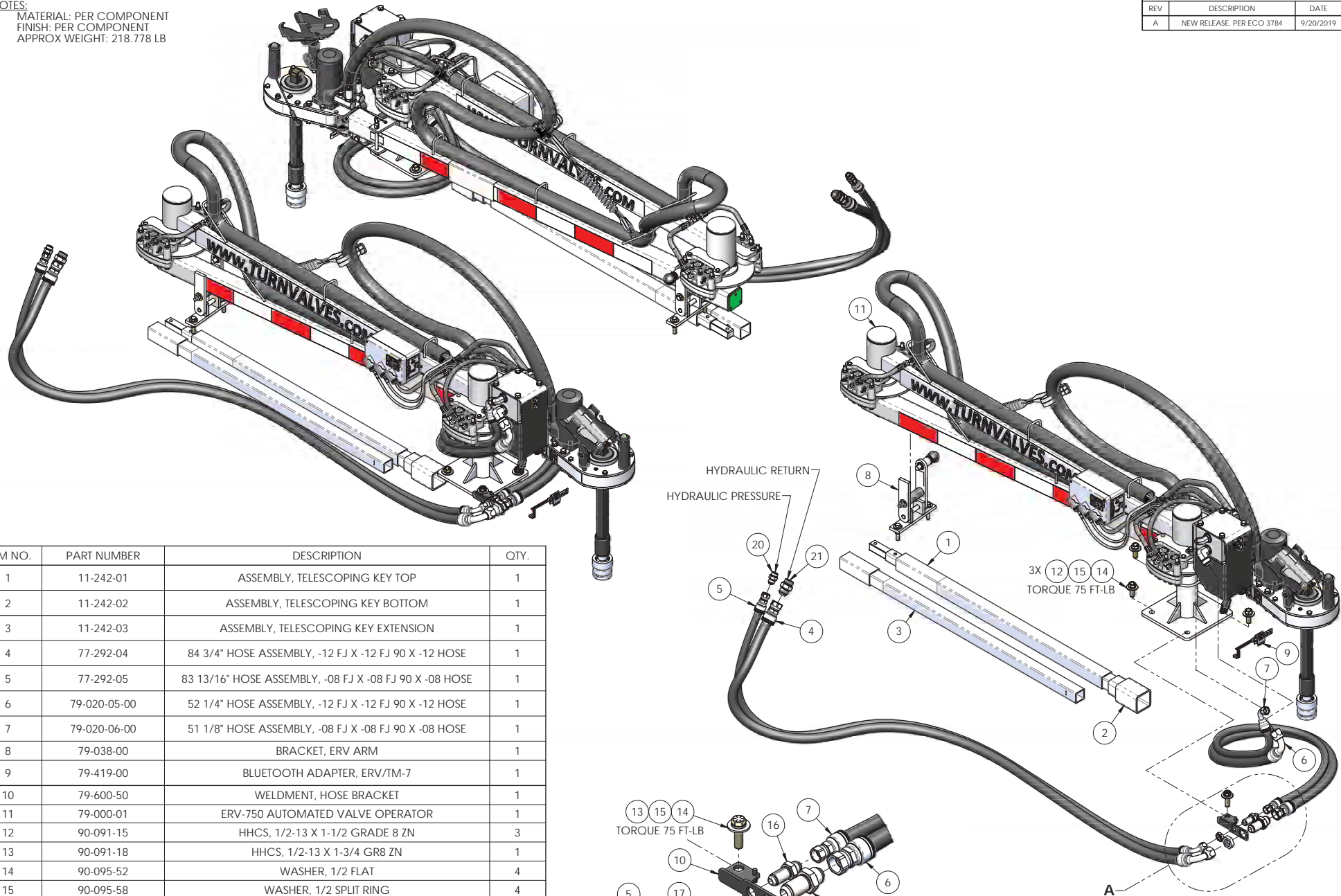

ITEM NO.	PART NUMBER	DESCRIPTION	QTY.
1	11-242-01	ASSEMBLY, TELESCOPING KEY TOP	1
2	11-242-02	ASSEMBLY, TELESCOPING KEY BOTTOM	1
3	11-242-03	ASSEMBLY, TELESCOPING KEY EXTENSION	1
4	77-292-04	84 3/4" HOSE ASSEMBLY, -12 FJ X -12 FJ 90 X -12 HOSE	1
5	77-292-05	83 13/16" HOSE ASSEMBLY, -08 FJ X -08 FJ 90 X -08 HOSE	1
6	79-020-05-00	52 1/4" HOSE ASSEMBLY, -12 FJ X -12 FJ 90 X -12 HOSE	1
7	79-020-06-00	51 1/8" HOSE ASSEMBLY, -08 FJ X -08 FJ 90 X -08 HOSE	1
8	79-038-00	BRACKET, ERV ARM	1
9	79-419-00	BLUETOOTH ADAPTER, ERV/TM-7	1
10	79-600-50	WELDMENT, HOSE BRACKET	1
11	79-000-01	ERV-750 AUTOMATED VALVE OPERATOR	1
12	90-091-15	HHCS, 1/2-13 X 1-1/2 GRADE 8 ZN	3
13	90-091-18	HHCS, 1/2-13 X 1-3/4 GR8 ZN	1
14	90-095-52	WASHER, 1/2 FLAT	4
15	90-095-58	WASHER, 1/2 SPLIT RING	4
16	90-098-30	ADAPTER, -8 JIC-M (3/4-16) X -8 JIC-M BULKHEAD	1
17	90-098-31	NUT, -8 (3/4-16) BULKHEAD	1
18	90-218-96	ADAPTER, -12 JIC-M X -12 JIC-M BULKHEAD	1
19	90-218-98	NUT, -12 (1-1/16" - 12) BULKHEAD	1
20	910-8-F5OX-S	ADAPTER, -8 JIC-M (3/4" - 16) X -8 ORB-M (3/4"-16)	1
21	910-12-F5OX-S	ADAPTER, -12 JIC-M (1 1/16-12) X -12 ORB-M (1 1/16-12)	1

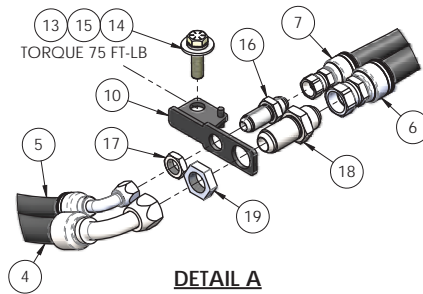

DETAIL A
 SCALE 1 : 4

THIRD ANGLE PROJECTION		UNLESS OTHERWISE SPECIFIED		
DIMENSIONS ARE IN INCHES		TOLERANCES:		
APPLY WORKMANSHIP		FRACTIONS 1/32"		
STANDARD W/ 17-00		ONE PLACE DECIMAL ±0.015		
RESURFACING AND TOL PER		TWO PLACE DECIMAL ±0.010		
LATEST ADAPT Y14.5M STANDARD		THREE PLACE DECIMAL ±0.005		
DO NOT SCALE DRAWINGS		ANGULAR DECIMAL ±.1°		
PROPRIETARY AND CONFIDENTIAL. THE INFORMATION CONTAINED IN THIS DRAWING IS THE SOLE PROPERTY OF E.H. WACHS. ANY REPRODUCTION IN PART OR AS A WHOLE WITHOUT THE WRITTEN PERMISSION OF E.H. WACHS IS PROHIBITED.				
DATE	4/22/2019	DATE	9/20/2019	
SIZE	C	DWG. NO.	79-404-00	
DRAWN BY	RJ	APPROVED BY	MWW	
TITLE	ERV-750 FOR VMS KIT		SCALE	1:8
SHEET	1 OF 1		REV.	A

E.H. WACHS
 Utility Products
 600 Knightsbridge Parkway
 Lincolnshire, IL 60069
 www.ehwachs.com

NOTES:

1. MATERIAL: PER COMPONENT
2. HYDRAULIC OIL:
 1. FACTORY SUPPLIED WITH PREMIUM GRADE ANTI-WEAR ISO-32
 2. ISO-46 RECOMMENDED FOR HIGH TEMP ENVIRONMENTS
3. RECOMMENDED OPERATING OIL VISCOSITY: 100 - 450 SSU [20 - 85 cSt]
4. RESERVOIR CAPACITY: 10 GALLONS
5. FAN TURN-ON OIL TEMP: 120°F
6. OVER-HEAT OIL TEMP: 185°F (CIRCUITS WILL BYPASS)
7. OPERATING TEMPERATURE: -10° TO 120° F [-23° TO 49° C]
8. COLD WEATHER START-UP:
 1. HYDRAULIC FLUID BECOMES THICK IN COLD WEATHER
 2. RUN AT LOW FLOW WITH MINIMAL LOAD
 3. ALLOW HYDRAULIC OIL TO WARM UP TO 50°F [10° C] BEFORE OPERATING UNDER LOAD
9. APPROX WEIGHT: 265 LB FULL WITH HYDRAULIC OIL
192 LB DRY

REVISION HISTORY			
REV	DESCRIPTION	DATE	APR
A	NEW RELEASE - ECO 3443	6/25/2019	MWW

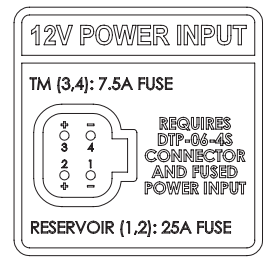
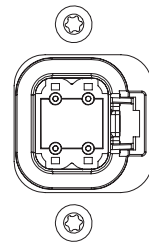
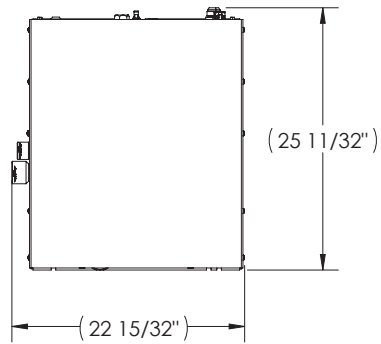

**DETAIL A
SCALE 1 : 1**

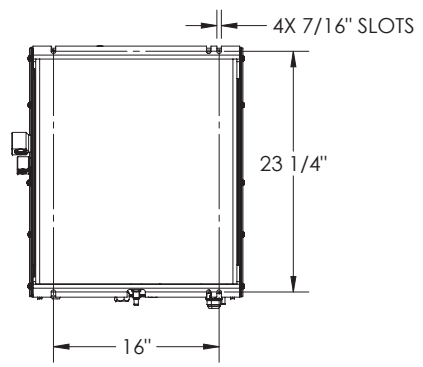
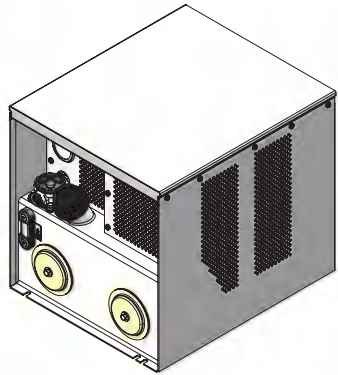
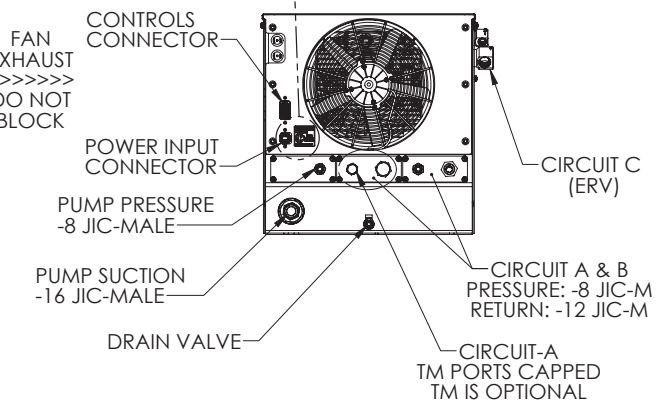
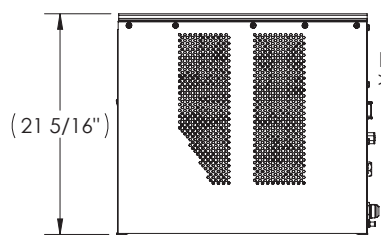
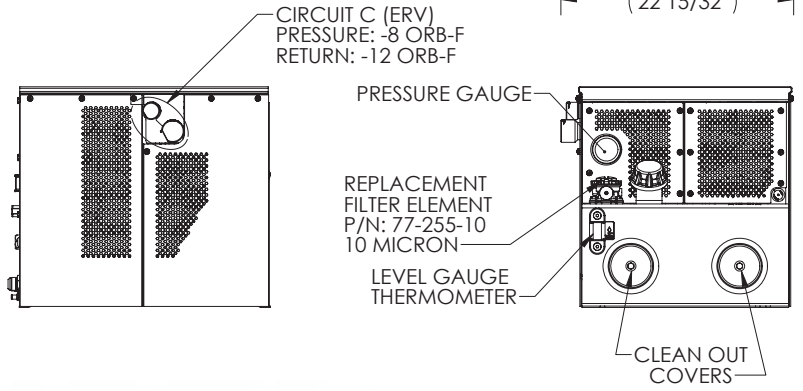

E.H. WACHS
Utility Products
600 Knightsbridge Parkway
Lincolnshire, IL 60069
www.ehwachs.com

TITLE: RESERVOIR ASSEMBLY, 3 CIRCUIT SKIDS

THIRD ANGLE PROJECTION	DIMENSIONS ARE IN INCHES	UNLESS OTHERWISE SPECIFIED:
	APPLY WORKMANSHIP STANDARD W/ 17-02	TOLERANCES: FRACTIONS ±1/32" ONE PLACE DECIMAL ±0.015 TWO PLACE DECIMAL ±0.010 THREE PLACE DECIMAL ±0.005 ANGULAR ±15 MINUTES
	INTERPRET DIM AND TOL PER LATEST ASME Y14.5M STANDARD	DO NOT SCALE DRAWING

DRAWN BY MWW	APPROVED BY MWW	SCALE 1:12
DATE 08/01/2018	DATE 10/10/2018	SHEET 1 OF 5

PROPRIETARY AND CONFIDENTIAL: THE INFORMATION CONTAINED IN THIS DRAWING IS THE SOLE PROPERTY OF E.H. WACHS. ANY REPRODUCTION IN PART OR AS A WHOLE WITHOUT THE WRITTEN PERMISSION OF E.H. WACHS IS PROHIBITED.

SIZE B	DWG. NO. 77-285-03	REV. A
-----------	------------------------------	-----------

ITEM	PART NUMBER	QTY	DESCRIPTION
1	77-185-55	1	OIL DRAIN VALVE, 1/2-20 X 3/8" HOSE
2	77-243-01	1	27-3/16" HOSE ASSEMBLY, -12FJ X -12FJ X -12 HOSE
3	77-243-02	1	30" HOSE ASSEMBLY, -12 FJ X -12 FJ X -12 HOSE
4	77-243-03	2	19-3/16" HOSE ASSEMBLY, -12 FJ X -12 FJ X -12 HOSE
5	77-243-00	3	19-7/8" HOSE ASSEMBLY, -08 FJ X -08 FJ 90 X -08 HOSE
6	77-246-15	1	WELDMENT, RESERVOIR TOP COVER
7	77-246-20	1	SIDE PANEL, RIGHT FULL
8	77-246-22	1	SWIVEL COVER PANEL
9	77-246-23	1	SIDE PANEL, BACK LEFT
10	77-246-24	1	SIDE PANEL, FRONT LEFT
11	77-246-25	1	GAUGE COVER PLATE
12	77-246-60	2	RESERVOIR ACCESS COVER, 6"
13	77-246-70	1	STRAINER BASKET WITH CHAIN
14	77-246-75	1	FILLER CAP WITH BREATHER
15	77-246-00	1	WELDMENT, RESERVOIR
16	77-249-03	1	MANIFOLD ASSEMBLY 3 CIRCUIT SELECTOR
17	77-255-01	1	HYDRAULIC OIL FILTER, IN-TANK RETURN
18	77-255-10	1	FILTER ELEMENT, 10 MICRON
19	77-255-50	1	SUCTION STRAINER, 149 MICRON W/ 5 PSI BYPASS
20	77-256-01	1	RESERVOIR SIGHT LEVEL/THERMOMETER 3" CENTER
21	77-257-01	1	TEMP SWITCH, 120F NO SPST-6 SAE ORB
22	77-257-02	1	TEMP SWITCH, 180F SPDT-8 SAE ORB
23	77-258-10	1	HYDRAULIC COOLER, 12 VDC
24	77-258-12	1	FAN SHROUD
25	77-258-14	1	LOWER COOLER SUPPORT
26	77-259-02	2	BULKHEAD PLATE, -8 + -12
27	77-259-03	1	BULKHEAD PLATE, -8
28	77-264-02	1	FRONT PANEL, NO CONTROLS
29	77-267-03	1	LABEL, OIL LEVEL
30	77-267-04	1	LABEL, 12V POWER INPUT-RESERVOIR
31	77-269-01	1	PRESSURE GAUGE, 0-3000 PSI
32	77-273-07	2	HOLE PLUG, 3/4"
33	77-273-08	1	HOLE PLUG, 7/8"
34	77-274-02	1	WIRE HARNESS, RESERVOIR NO CONTROLS
35	77-277-01	2X 18"	EDGE TRIM, 1/16" EDGE X 5/16" NEOPRENE (INCH)

ITEM	PART NUMBER	QTY	DESCRIPTION
36	77-288-01	41"	PUSH-ON BULB SEAL, 1/16" EDGE X 3/8" BULB
37	79-102-06	1	HOSE ASSEMBLY, 1/4" HYDRAULIC 16-1/2" LONG
38	90-030-00	4	TPHST, M4.5 X 14mm
39	90-055-12	38	PHMS, M6 X 16 DOUBLE SEMS
40	90-058-13	1	ELBOW, 1/4 NPT-F X -04 JIC-M (7/16-20)
41	90-078-19	1	ADAPTER, -6 ORB-M (9/16-18) X -4 JIC-M (7/16-20)
42	90-088-90	1	PLUG, SAE -10 ORB (7/8-14)
43	90-098-30	3	ADAPTER, -8 JIC-M (3/4-16) X -8 JIC-M BULKHEAD
44	90-098-31	3	NUT, -8 (3/4-16) BULKHEAD
45	90-098-77	1	-8 (3/4-16) JIC CAP
46	90-1002-30	4	HHCS, M8 X 1.25MM X 30MM
47	90-1055-16	12	HHFS, M8-1.25 X 16 mm ISO 4162 8.8 ZN
48	90-1056-20	3	HHFS, M10-1.5 X 20 mm ISO 4162 8.8 ZN
49	90-200-10	1	SWIVEL, -10 ORB M X -8 ORB F 90
50	90-200-12	1	SWIVEL, -12 ORB M X -12 ORB F 90
51	90-208-10	3	ADAPTER, -10 ORB M (7/8"-14) X -8 JIC M (3/4"-16)
52	90-218-40	1	-12 (1 1/16 - 12) JIC CAP
53	90-218-81	1	ADAPTER, -12 ORB-M (1-1/16" - 12) X -8 ORB-F (3/4"-16)
54	90-218-96	2	ADAPTER, -12 JIC-M X -12 JIC-M BULKHEAD
55	90-218-98	2	NUT, -12 (1-1/16" - 12) BULKHEAD
56	90-238-66	2	ELBOW, -16 ORB M X -12 JIC M
57	90-238-67	1	ADAPTER, -16 ORB-M (1-5/16"-12) X -16 JIC-M
58	90-903-10	2	CUSHIONED LOOP CLAMP, 1"
59	910-12-C5OX-S	1	ELBOW, -12 M JIC (1-1/16"-12) X -12 M ORB (1-1/16"-12) 90
60	910-12-F5OX-S	3	ADAPTER, -12 JIC-M (1 1/16-12) X -12 ORB-M (1 1/16-12)

 E.H. WACHS Utility Products 600 Knightsbridge Parkway Lincolnshire, IL 60069 www.ehwachs.com		
TITLE RESERVOIR ASSEMBLY, 3 CIRCUIT SKIDS		
DRAWN BY MWW	APPROVED BY MWW	SCALE 1:12
DATE 08/01/2018	DATE 10/10/2018	SHEET 2 OF 5
SIZE B	DWG. NO. 77-285-03	
		REV. A

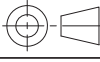
	<small>THIRD ANGLE PROJECTION</small>
	<small> DIMENSIONS ARE IN INCHES APPLY WORKMANSHIP STANDARD W/ 17-02 INTERPRET DIM AND TOL PER LATEST ASME Y14.5M STANDARD DO NOT SCALE DRAWING </small>
<small> UNLESS OTHERWISE SPECIFIED: TOLERANCES: FRACTIONS ±1/32" ONE PLACE DECIMAL ±0.015 TWO PLACE DECIMAL ±0.010 THREE PLACE DECIMAL ±0.005 ANGULAR ±15 MINUTES </small>	
<small> PROPRIETARY AND CONFIDENTIAL: THE INFORMATION CONTAINED IN THIS DRAWING IS THE SOLE PROPERTY OF E.H. WACHS. ANY REPRODUCTION IN PART OR AS A WHOLE WITHOUT THE WRITTEN PERMISSION OF E.H. WACHS IS PROHIBITED. </small>	

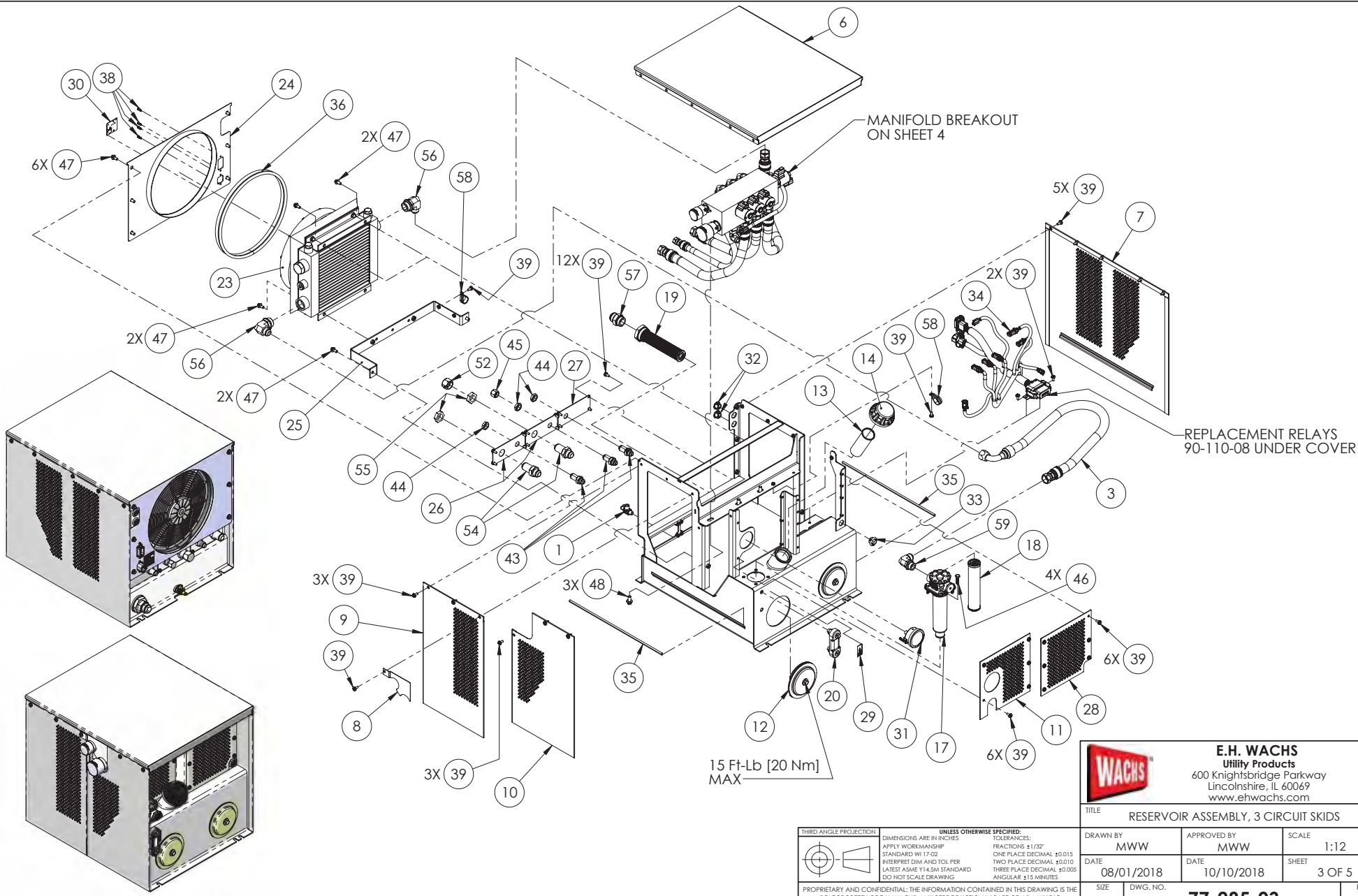

THIRD ANGLE PROJECTION

DIMENSIONS ARE IN INCHES
 APPLY WORKMANSHIP
 STANDARD W/ 17-02
 INTERPRET DIM AND TOL PER
 LATEST ASME Y14.5M STANDARD
 DO NOT SCALE DRAWING

UNLESS OTHERWISE SPECIFIED:
 FOLERANCES:
 FRACTIONS ±1/32"
 ONE PLACE DECIMAL ±0.015
 TWO PLACE DECIMAL ±0.010
 THREE PLACE DECIMAL ±0.005
 ANGULAR ±15 MINUTES

PROPRIETARY AND CONFIDENTIAL: THE INFORMATION CONTAINED IN THIS DRAWING IS THE SOLE PROPERTY OF E.H. WACHS. ANY REPRODUCTION IN PART OR AS A WHOLE WITHOUT THE WRITTEN PERMISSION OF E.H. WACHS IS PROHIBITED.

E.H. WACHS Utility Products 600 Knightsbridge Parkway Lincolnshire, IL 60069 www.ehwachs.com		
TITLE RESERVOIR ASSEMBLY, 3 CIRCUIT SKIDS		
DRAWN BY MWW	APPROVED BY MWW	SCALE 1:12
DATE 08/01/2018	DATE 10/10/2018	SHEET 3 OF 5
SIZE B	DWG. NO. 77-285-03	REV. A

12V POWER INPUT

TM (3,4): 7.5A FUSE



RESERVOIR (1,2): 25A FUSE

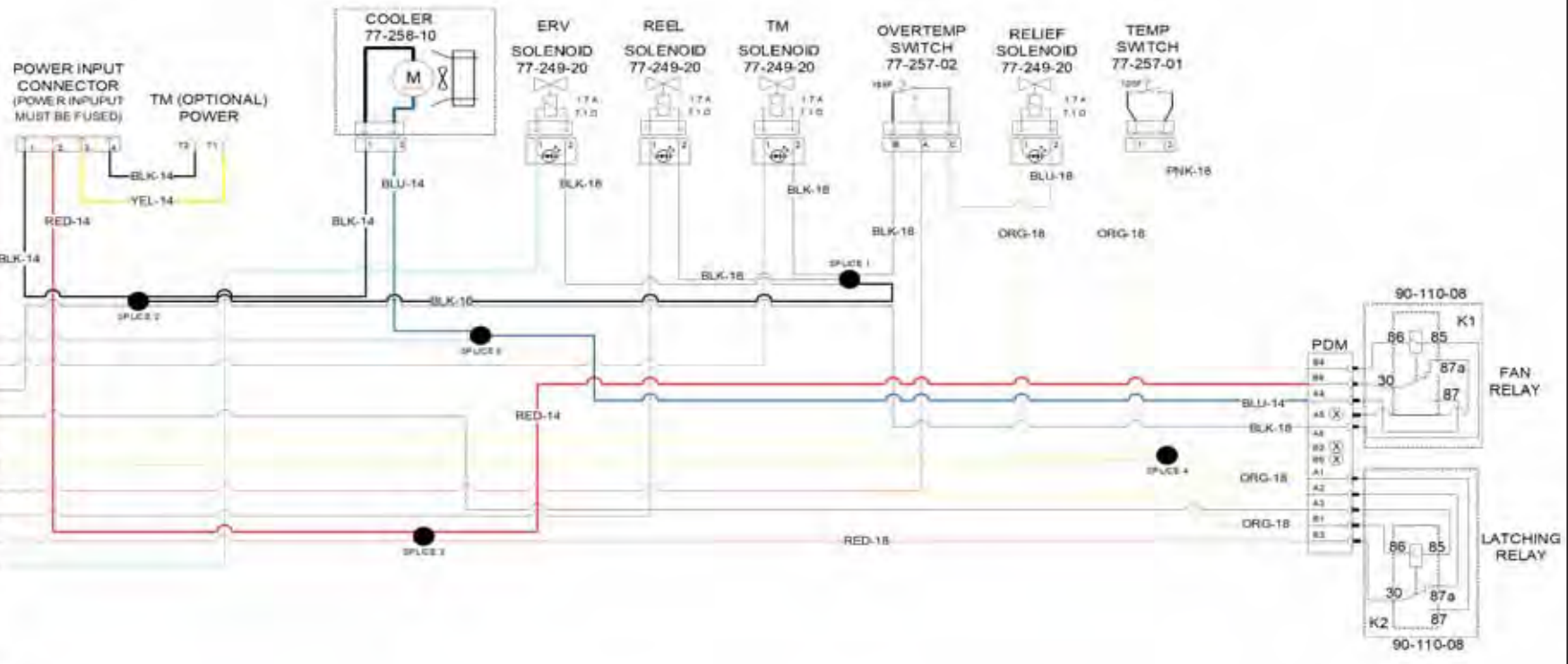

ELECTRICAL SCHEMATIC

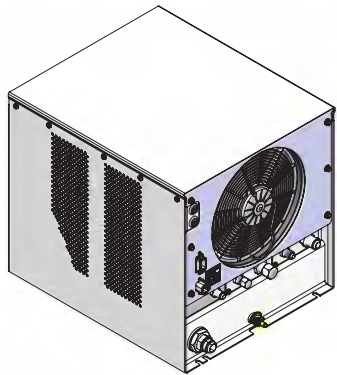

CONTROLS CONNECTOR		
CAVITY	WIRE COLOR	FUNCTION
1	N/A	PLUGGED
2	BLUE	FAN ON INDICATOR +12V (FAN POWER)
3	PURPLE	TM SOLENOID +12V
4	BLACK	CONTROLS GROUND
5	GRAY	LATCHING RELAY GROUND
6	YELLOW	OFF LED POWER (LATCHING RELAY OFF)
7	ORANGE	SWITCH POWER (LATCHING RELAY ON; RELIEF SOL ON)
8	RED	OVERTEMP INDICATOR RETURN TO GROUND
9	BROWN	REEL SOLENOID +12V
10	RED	CONTROLS +12V POWER (POWER INPUT CONNECTOR)
11	GREEN	ERV SOLENOID +12V
12	N/A	PLUGGED

	DIMENSIONS ARE IN INCHES APPLY WORKMANSHIP STANDARD W/ 17-02 INTERPRET DIM AND TOL PER LATEST ASME Y14.5M STANDARD DO NOT SCALE DRAWING	UNLESS OTHERWISE SPECIFIED: TOLERANCES: FRACTIONS ±1/32" ONE PLACE DECIMAL ±0.015 TWO PLACE DECIMAL ±0.010 THREE PLACE DECIMAL ±0.005 ANGULAR ±15 MINUTES
	PROPRIETARY AND CONFIDENTIAL: THE INFORMATION CONTAINED IN THIS DRAWING IS THE SOLE PROPERTY OF E.H. WACHS. ANY REPRODUCTION IN PART OR AS A WHOLE WITHOUT THE WRITTEN PERMISSION OF E.H. WACHS IS PROHIBITED.	

E.H. WACHS
 Utility Products
 600 Knightsbridge Parkway
 Lincolnshire, IL 60069
 www.ehwachs.com

TITLE: RESERVOIR ASSEMBLY, 3 CIRCUIT SKIDS

DRAWN BY MWW	APPROVED BY MWW	SCALE 1:12
DATE 08/01/2018	DATE 10/10/2018	SHEET 5 OF 5

SIZE: B DWG. NO.: **77-285-03** REV. A

NOTES:

1. TM-7 HD PLUS KIT FOR STANDARD LX AND BUILDER SKIDS (77-000-54 / .55 / .60 / .61)
2. WHEN ORDERED WITH THE VMS SYSTEM, TM-7 HD PLUS IS FACTORY INSTALLED IN THE INNERMOST POSITION
3. TM-7 HD PLUS MAY BE RELOCATED OUTWARD 6 PLACES IN 2-1/2" INCREMENTS
4. CUSTOMER/TRUCK BODY COMPANY ARE RESPONSIBLE FOR REPLACING OR LENGTHENING THE HYDRAULIC HOSES AND WIRING FOR FOR INSTALLING THE TM-7 HD PLUS IN POSITIONS BEYOND THE FACTORY INSTALLED INNERMOST
5. SEE SHEET 2 FOR TM-7 HD PLUS PLACEMENT AND INSTALLATION
6. HYDRAULIC FITTING TORQUE SPECS ONLY FOR INSTALLATION PURPOSES
- 7.
8. USE THE INCLUDED BOLTS AND ITEM 2 TO INSTALL TM7 FRAME TO SKID
9. USE (6X) CUSTOMER SUPPLIED 1/2-13 GRADE 5 BOLTS TO SECURE TM-7 TO TRUCK BED
 1. PREFERRED MOUNTING LOCATIONS INDICATED WITH \diamond
 2. TORQUE BOLTS TO 57 FT.LBS
10. REFER TO DRAWING 17-000-30 FOR HYDRAULIC AND ELECTRICAL SCHEMATICS
11. APPROX WEIGHT: 1230.582 LB

REVISION HISTORY			
REV	DESCRIPTION	DATE	APR
A	NEW RELEASE PER ECD 3787	8/7/2019	HW

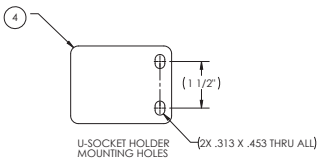
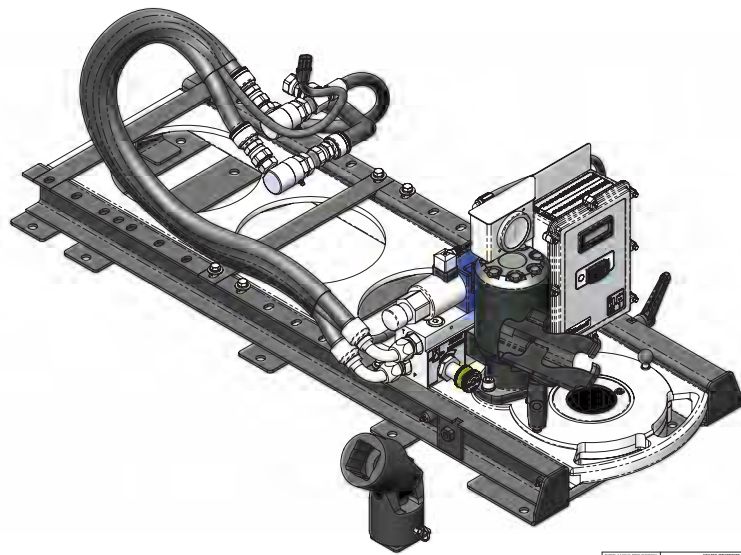
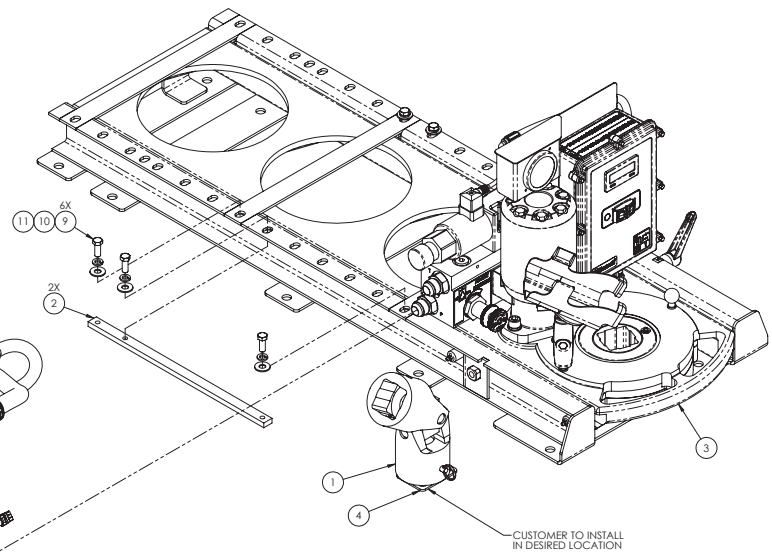
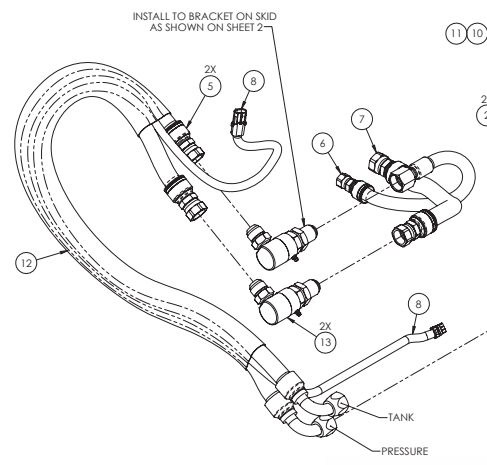
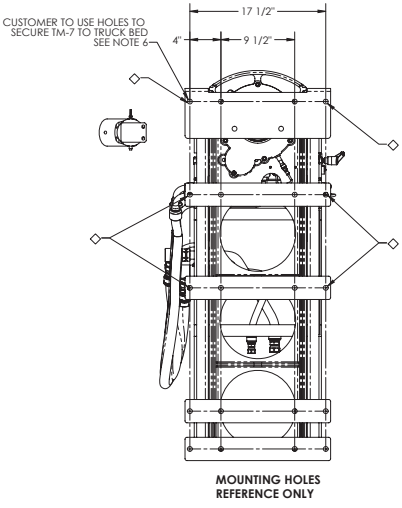

ITEM	PART NUMBER	QTY	DESCRIPTION
1	07-508-20	1	ASSEMBLY, 2" H.T. U-SOCKET
2	17-153-00	2	BAR, TM CLAMP
3	17-000-30	1	TM-7 HD PLUS
4	77-290-36	1	WELDMENT, H.T. U-SOCKET HOLDER
5	77-292-01	2	47 3/4" HOSE ASSEMBLY, -12 FJ X -12 FJ 90 X -12 HOSE
6	77-292-10	1	20 13/16" HOSE ASSEMBLY, -12 FJ X -08 FJ X -08 HOSE
7	77-292-11	1	19 7/16" HOSE ASSEMBLY, -12 FJ X -12 FJ X -12 HOSE
8	77-520-03-28	1	WIRE HARNESS, TM-POWER
9	90-071-10	6	HHCS, 3/8-16 X 1
10	90-075-52	6	WASHER, 3/8 SPLIT RING
11	90-075-53	6	WASHER, 3/8 FLAT
12	90-203-01	1	2" BALLISTIC NYLON SLEEVE
13	90-218-83	2	SWIVEL, -12 MJ X -12 MJ 90



Wach's
E.H. WACHS
Utility Products
600 Knightbridge Parkway
Lincolnshire, IL 60069
www.ehwach.com

FILE: TM-7 HD FOR VMS KIT

DESIGNED BY	HM	APPROVED BY	SCALE
DRAWN BY	HM	Approved By Initials	1/4
DATE	8/7/2019	Approved Date	SHEET 1 OF 3
SIZE	D	17-405-00	REV. A

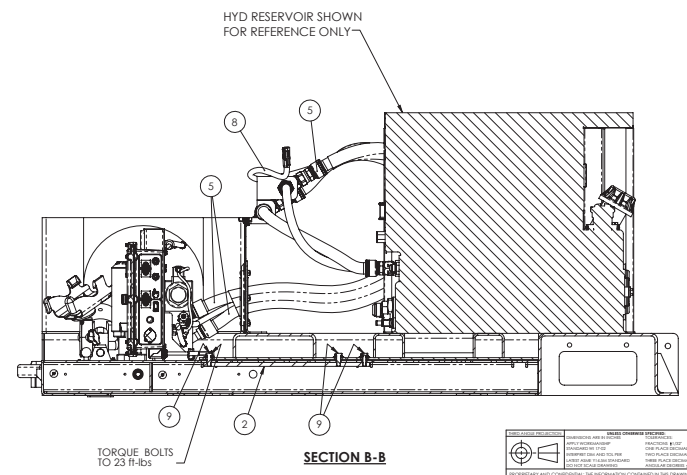
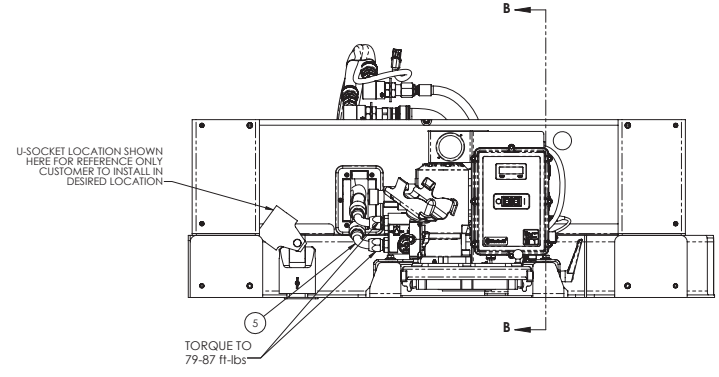
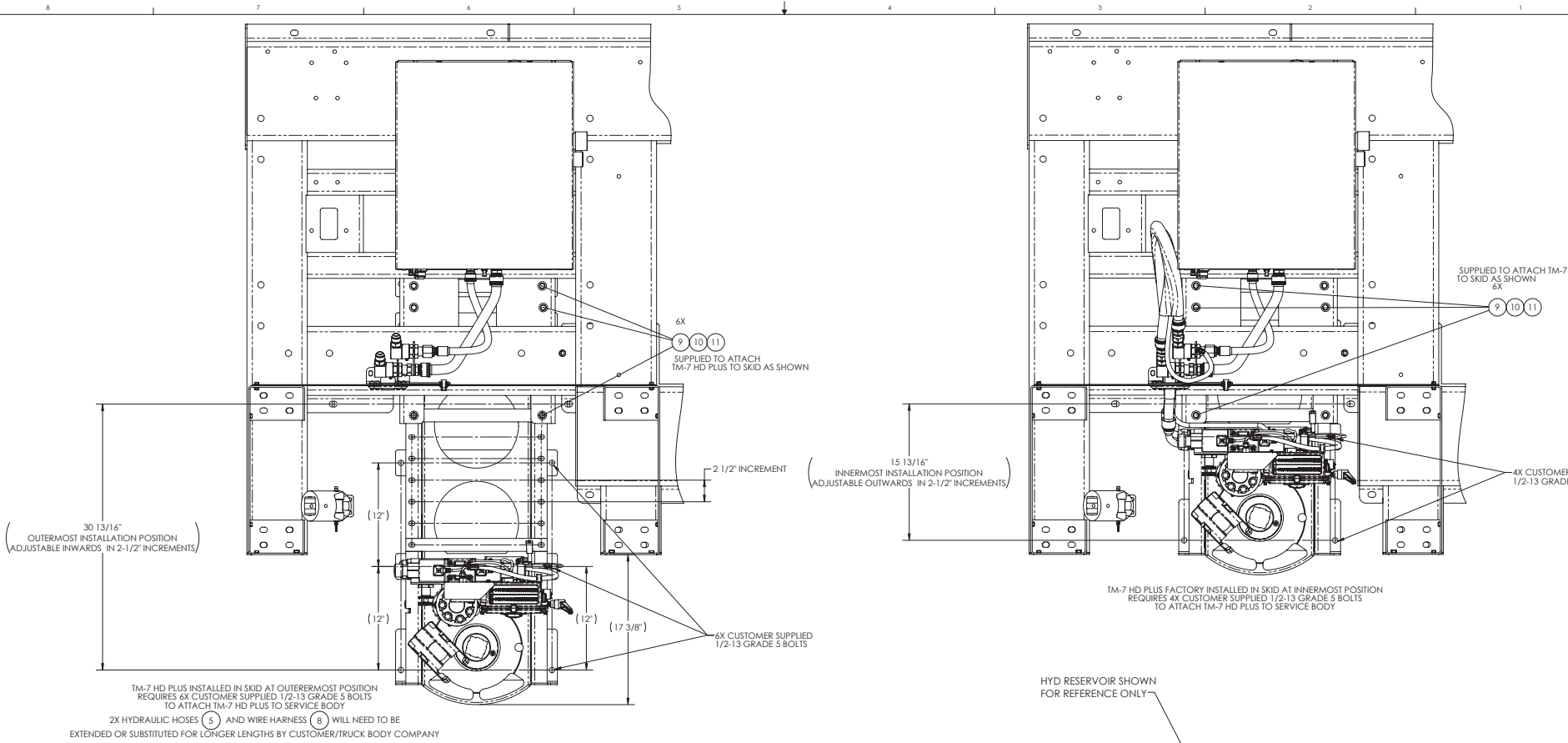

		E.H. WACHS Utility Products 600 Knightbridge Parkway Lincolnshire, IL 60069 www.ehwachs.com	
DATE	8/7/2019	REV.	D
DESCRIPTION	TM-7 HD FOR VMS KIT	APPROVED BY	HM
SCALE	1:6	APPROVED DATE	8/7/2019
SHEET	2 OF 3	REV.	A
17-405-00			

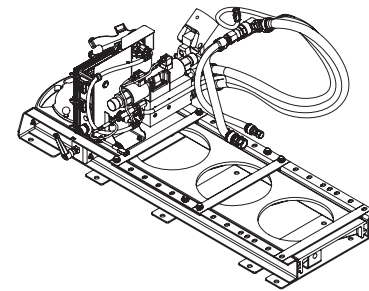
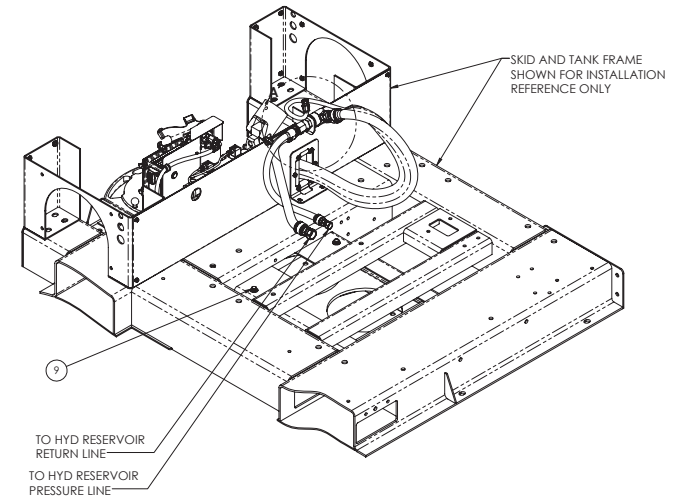
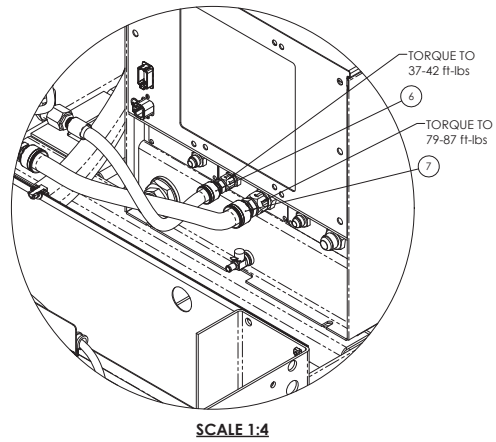
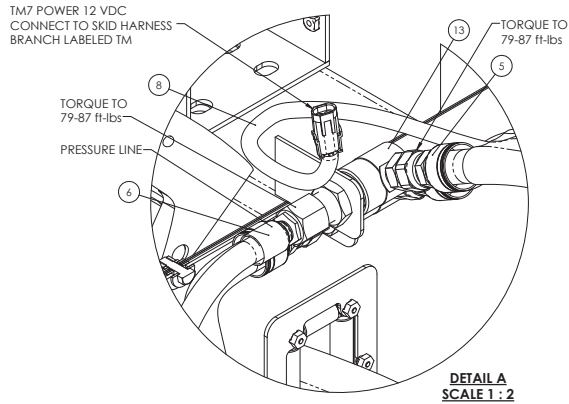

 E.H. WACHS Utility Products 600 Knightbridge Parkway Lincolnshire, IL 60069 www.ehwachs.com	
TITLE: TM-7 HD FOR VMS KIT	
DRAWN BY: HM	APPROVED BY: [Signature]
DATE: 8/7/2019	APPROVED DATE:
SHEET: 3 OF 3	REV: A
17-405-00	

NOTES:

1. MATERIAL: PER COMPONENT
2. FINISH: PER COMPONENT
3. ALL WATER CONNECTIONS SHOULD BE LEAK FREE
 1. USE TEFLON TAPE OR EQUIVALENT WHEN APPLICABLE
4. INSTALL FUSE AND TERMINALS AS SHOWN IN SCHEMATIC PER IPC/MHMA-A-620
5. SKID INSTALLATION INSTRUCTIONS ON SHEET 2 & 3 (REFERENCE ONLY)
6. SEE SHEET 4 FOR MECHANICAL SCHEMATIC
7. SEE SHEET 5 FOR ELECTRICAL SCHEMATIC
8. APPROX. WEIGHT: TBD LB

REVISION HISTORY			
REV.	DESCRIPTION	DATE	APR.
1	PROTOTYPE RELEASE PER ECO 3016	5/23/2019	HM

SKID COMPONENTS SHOWN FOR REFERENCE

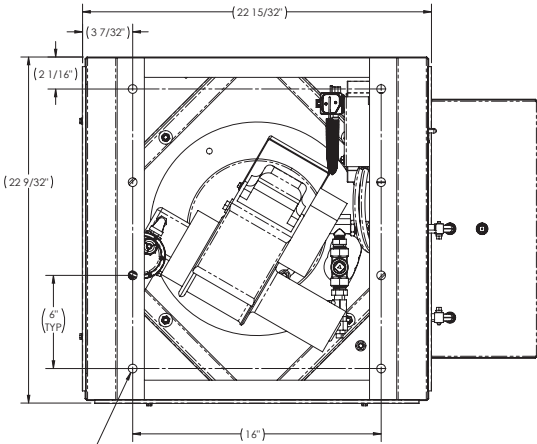

WATER HEATER MOUNTING HOLES REFERENCE ONLY

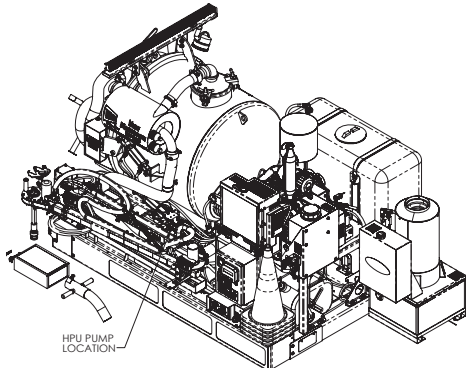

SKID SHOWN FOR REFERENCE ONLY

ITEM	PART NUMBER	QTY	DESCRIPTION	NOTES
1	48-201-00	1	QD COUPLER, 3/8" X 3/8" NPT-F	
2	48-202-50	1	QD PLUG, 3/8" X 3/8" NPT-F	
3	77-265-00	1	PRESSURE SWITCH	
4	77-274-10	1	ADJUSTABLE CHECK VALVE, 3/8 MNPT W/ .030 BLEED PORT	
5	77-280-02	1	HOT WATER HEATER	
6	77-292-16	1	HOSE ASSEMBLY	
7	77-381-20	1	FUSE, 20A J-CASE	
8	90-071-12	8	HHCS, 3/8-16 X 1-1/4 GRADE 5	
9	90-075-01	8	NUT, 3/8-16 HEX GR 5 ZN	
10	90-075-52	8	WASHER, 3/8 SPLIT RING	
11	90-075-53	16	WASHER, 3/8 FLAT	
12	90-078-15	1	TEE, 3/8 NPT-M X 3/8 NPT-F X 3/8 NPT-F STREET	
13	90-078-63	1	COUPLING, HEX 3/8-18 NPT F	
14	90-110-04	1	FUSE HOLDER, J-CASE WEATHER PROOF	
15	90-501-14	2	TERMINAL, 12-10 AWG 5/16" RING HT SHRINK	T1
16	90-501-34	1	TERMINAL, 12-10 AWG BUTTSPLICE ADHESIVE SHRINK	SPLICE
17	910-6-6-FIX-S	1	ADAPTER, 3/8-18 NPT M X 3/8 JIC M	

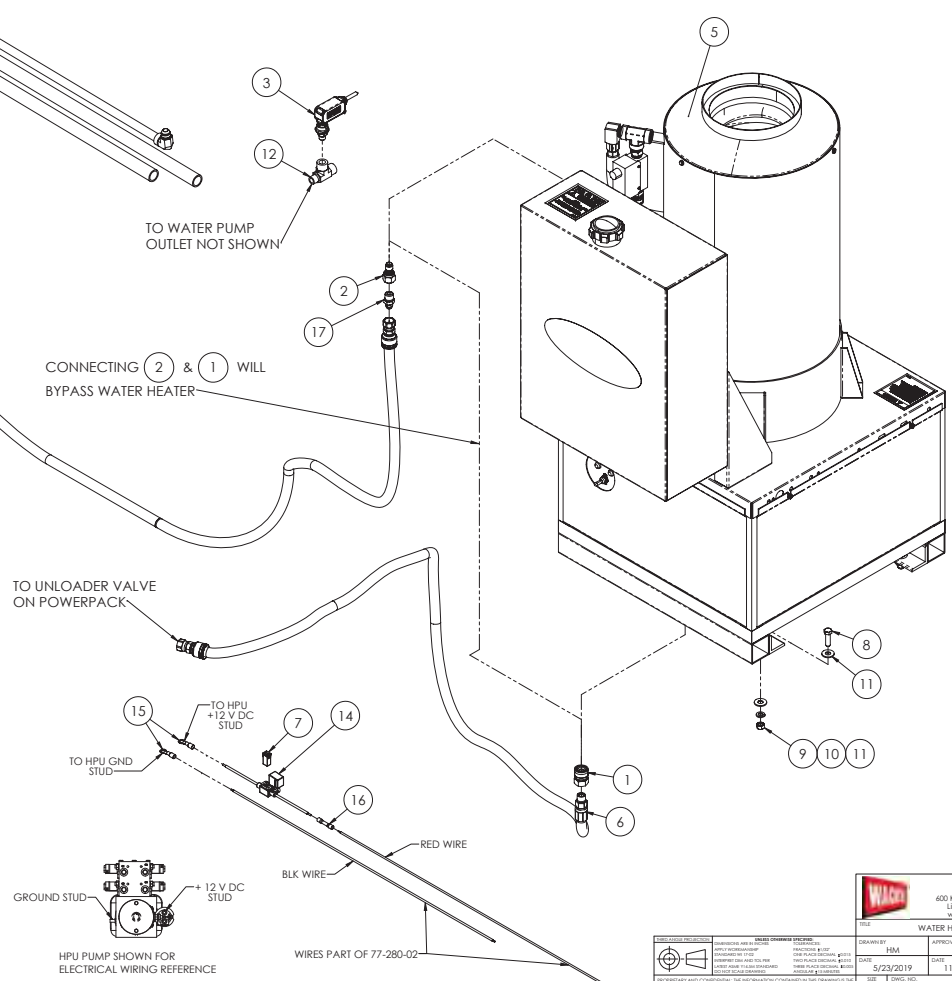

PROPOSED AND/OR MODIFIED: THIS REPRESENTS CHANGES TO THE ORIGINAL DESIGN. THIS REPRESENTS CHANGES TO THE ORIGINAL DESIGN. THIS REPRESENTS CHANGES TO THE ORIGINAL DESIGN.

E.H. WACHS
Utility Products
600 Knightbridge Parkway
Lincolnshire, IL 60069
www.ehwachspco.com

TITLE: WATER HEATER - VMS KIT			
DATE	BY	APPROVED BY	SCALE
5/23/2019	HM	RAW	1:24
DATE		DATE	SHEET
5/23/2019	11/26/2016	1	OF 5
REV. D	REV. 101	77-414-02	

WATER SUPPLY TO
WATER HEATER
(UNLOADER VALVE TO
WATER HEATER)

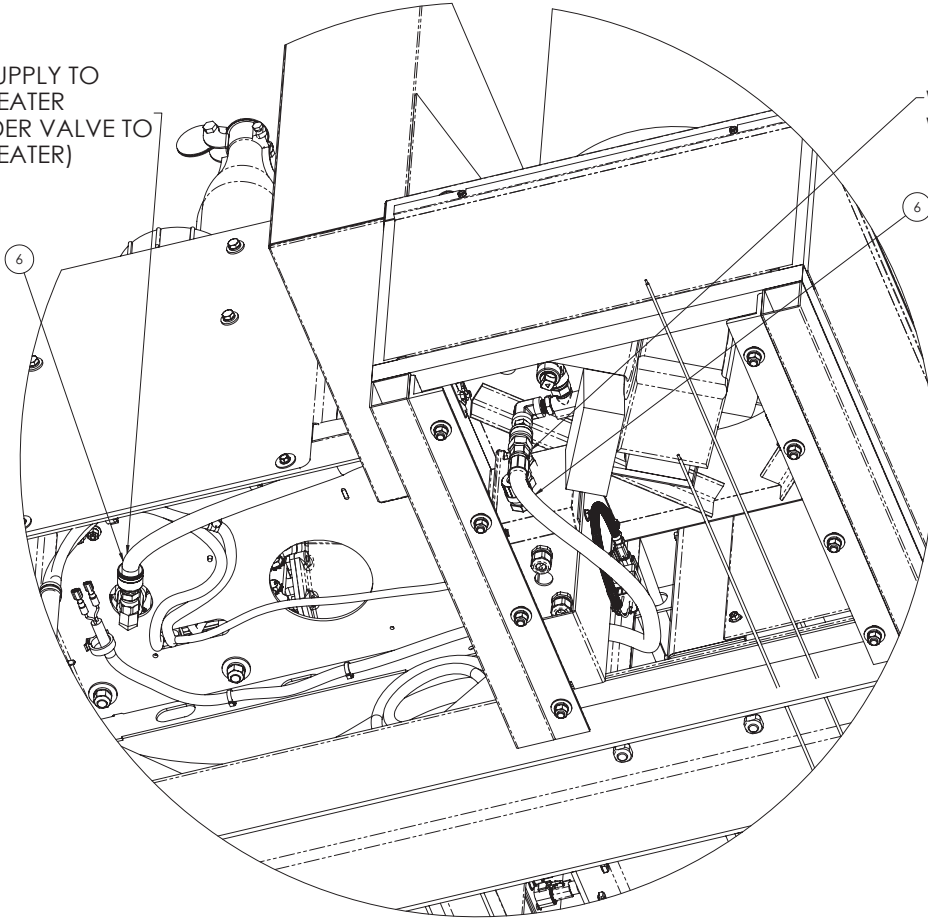

WATER SUPPLY TO
WATER HEATER

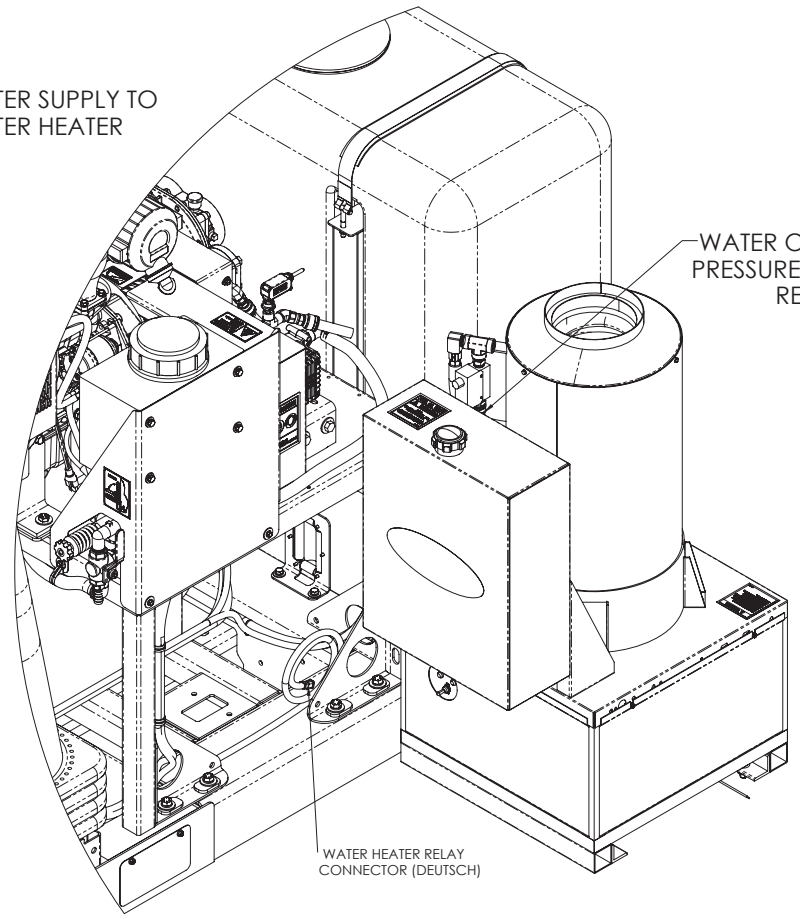

WATER OUTLET TO
PRESSURE WASHER
REEL

WATER HEATER RELAY
CONNECTOR (DEUTSCH)

 E.H. WACHS Utility Products 600 Knightbridge Parkway Lincolnshire, IL 60069 www.ehwachs.com		TITLE: WATER HEATER - VMS KIT	
		DRAWN BY: HM DATE: 5/23/2019	APPROVED BY: RAWW DATE: 11/26/2016
PROJECT: 77-414-02		REV: 1	

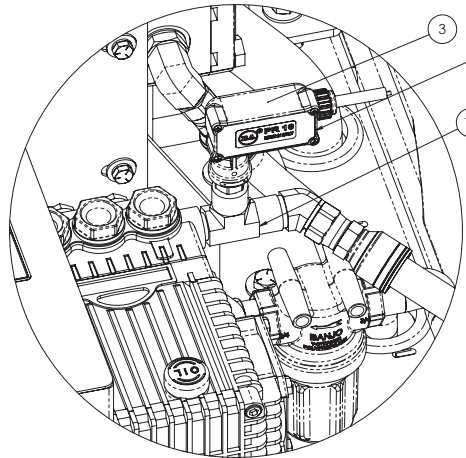

WATER HEATER
PRESSURE SWITCH

DETAIL A
SCALE 2 : 3

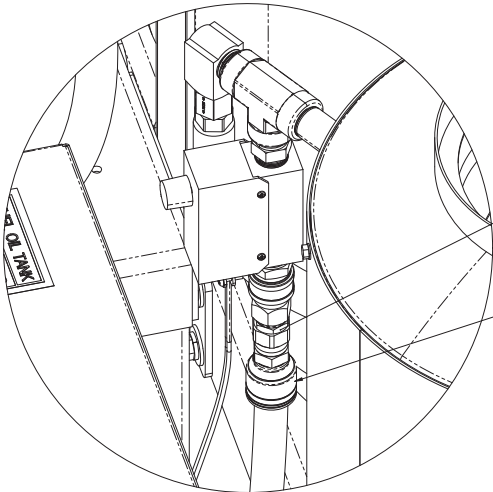

WATER HEATER OUTLET
TO HOSE REEL

DETAIL B
SCALE 2 : 3

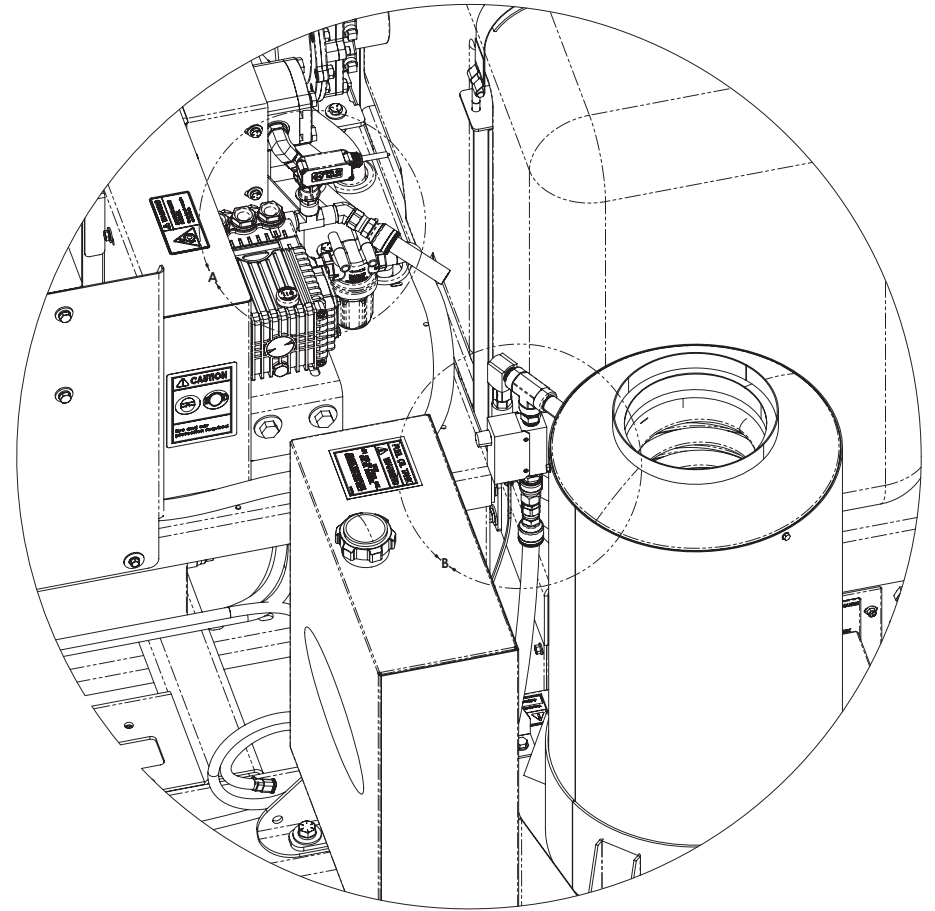

		E.H. WACHS Utility Products 600 Knightbridge Parkway Lincolnshire, IL 60069 www.ehwachs.com	
		TITLE WATER HEATER - VMS KIT	SCALE 1:24
DRAWN BY HM	APPROVED BY RAW	DATE 5/23/2019	SHEET 3 OF 5
PROPERTY AND COPYRIGHT, THE INFORMATION CONTAINED HEREIN IS THE PROPERTY OF E.H. WACHS. ALL RIGHTS RESERVED. THIS DOCUMENT IS UNCLASSIFIED.		77-414-02	REV. 1

**PARTS LIST TABLE FOR SCHEMATIC
REFERENCE ONLY**

ITEM	PART NUMBER	DESCRIPTION
1	68-137-01	VALVE, TRAPPED PRESSURE UNLOADER
2	68-138-02	STRAINER
3	68-141-10	BALL VALVE, 3-WAY
4	68-188-00	FLOW SWITCH
5	68-193-35	SAFETY RELIEF- 3500 PSI
6	68-195-50	HOSE REEL
7	68-199-00	SPRAY GUN
8	68-201-00	QD COUPLER, 3/8" X 3/8" NPT-F
9	68-202-00	QD PLUG, 3/8" x 3/8" NPT-M
10	68-202-50	QD PLUG, 3/8" x 3/8" NPT-F
11	77-068-25	STRAINER
12	77-085-00	PUMP PRESSURE WASHER 2.6 GPM, 3000 PSI
13	77-130-01	NOZZLE, .030 X 15 DEGREE
14	77-265-00	PRESSURE SWITCH
15	77-276-10	ADJUSTABLE CHECK VALVE, 3/8" MNPT W/.030 BLEED PORT
16	77-280-01	WATER HEATER
16.1	77-280-10	RUPTURE DISC ASSEMBLY, 7000 PSI
16.2	77-280-11	RELIEF VALVE
16.3	77-280-12	TEMPERATURE CONTROL SWITCH
16.4	77-280-13	FLOW SWITCH
17	77-292-12	151 5/16" HOSE ASSEMBLY, -08 FJ X -08 FJ X -08 HOSE
18	77-292-13	43 13/16" HOSE ASSEMBLY, -08 FJ X -08 FJ X -08 HOSE
19	77-292-16	HOSE ASSEMBLY
20	90-078-15	TEE, 3/8 NPT-M X 3/8 NPT-F X 3/8 NPT-F STREET
21	90-078-63	COUPLING, HEX 3/8-18 NPT F
22	90-078-84	ADAPTER, -8 (3/4" - 16)MJ X 3/8" NPT-F 90
23	910-6-6-FTX-S	ADAPTER, 3/8-18 NPT M X 3/8 JIC M

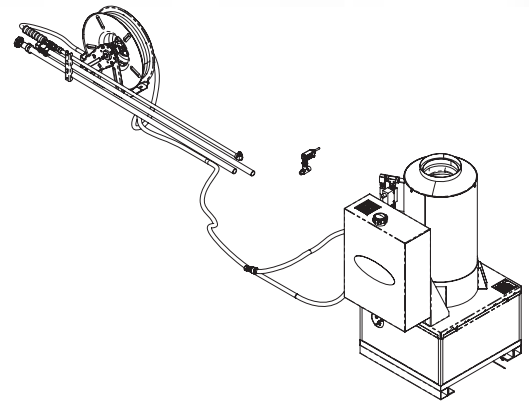
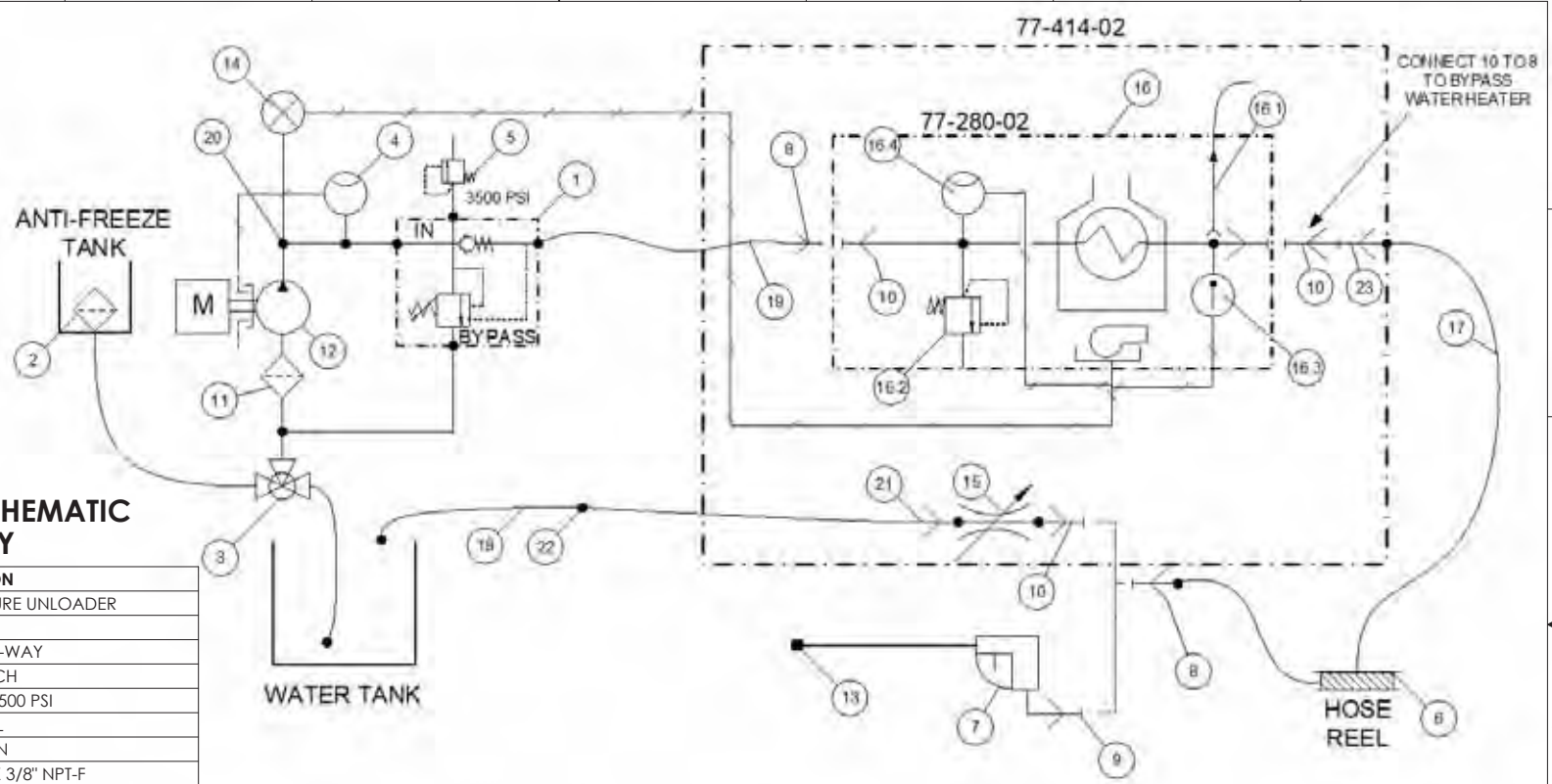

		E.H. WACHS Utility Products 600 Knightbridge Parkway Lincolnshire, IL 60069 www.ehwachs.com	
TITLE: WATER HEATER - VMS KIT			
DRAWN BY: HM DATE: 5/23/2019	APPROVED BY: RAW DATE: 11/26/2016	SCALE: 1:24 SHEET: 4 OF 5	REV: 1
PROJECT AND CUSTOMER: THE INFORMATION CONTAINED HEREIN IS THE PROPERTY OF E.H. WACHS. ANY REPRODUCTION OR TRANSMISSION OF THIS INFORMATION IS STRICTLY PROHIBITED.		77-414-02	

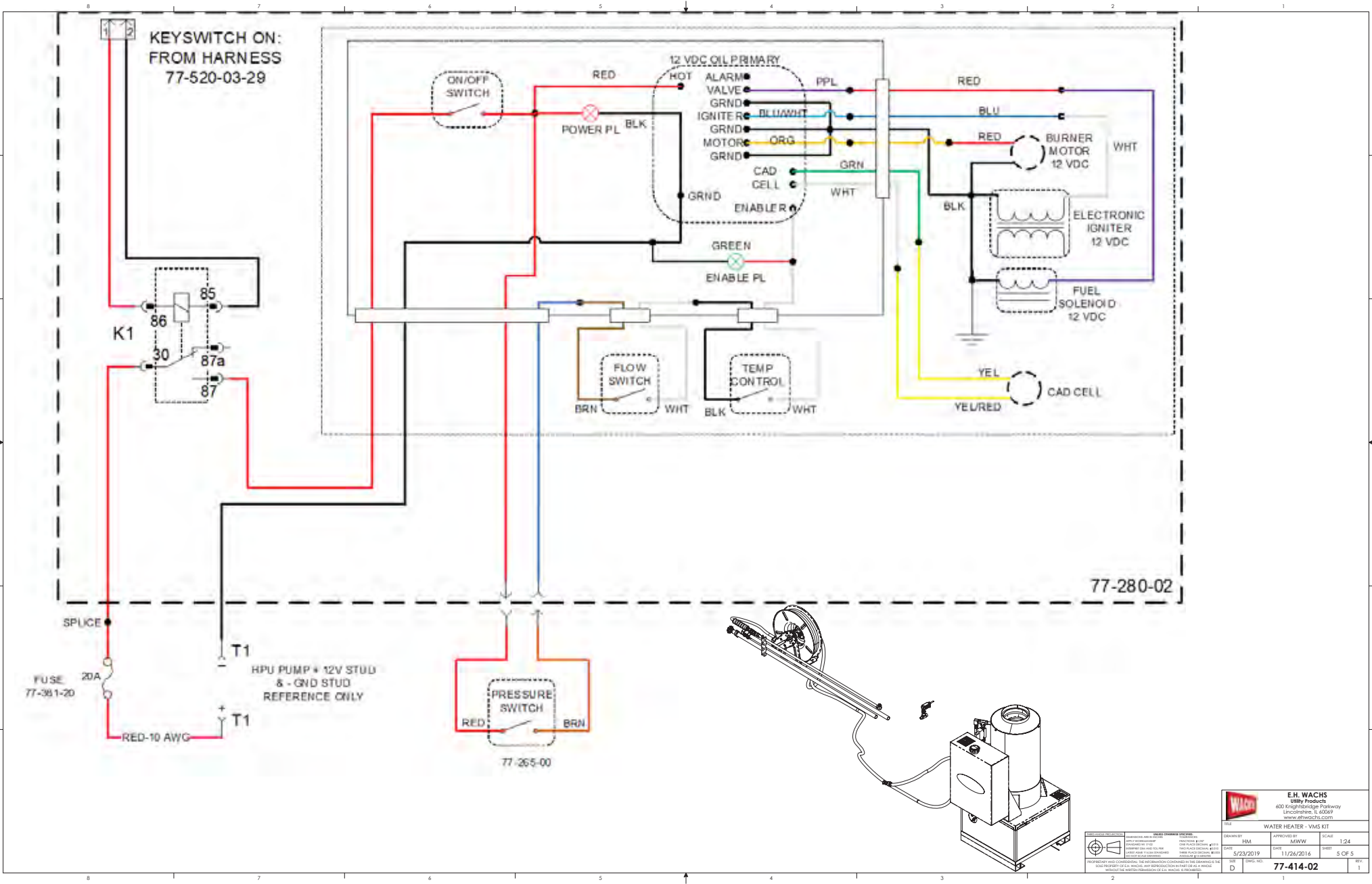

		E.H. WACHS Utility Products 600 Knightbridge Parkway Lincolnshire, IL 60069 www.ehwachs.com	
TITLE: WATER HEATER - VMS KIT			
DESIGNED BY: HM	APPROVED BY: RMW	SCALE: 1:24	
DATE: 5/23/2019	DATE: 11/26/2016	SHEET: 5 OF 5	
REV: D	77-414-02		

PROPERTY AND COPYRIGHT © E.H. WACHS. ALL INFORMATION CONTAINED HEREIN IS THE SOLE PROPERTY OF E.H. WACHS. ANY REPRODUCTION OR USE OF THIS PRODUCT WITHOUT THE WRITTEN PERMISSION OF E.H. WACHS IS PROHIBITED.

NOTES:

1. MATERIAL- PER COMPONENT
2. FINISH- PER COMPONENT
3. SEE WELDMENT 77-433-01 AND 77-431-03-10 FOR DECAL 77-160-90 PLACEMENT
4. REFER TO SCHEMATIC SHEET 4 REGARDING HOSE ROUTING DETAILS
5. USE THREAD SEALANT ON ALL FASTENERS
6. LIBERALLY APPLY GREASE TO ALL FRICTION LOCATIONS
7. APPROX WEIGHT: 180 LB ; CALCULATED WEIGHT: 980 LB (1)

REVISION HISTORY			
REV.	DESCRIPTION	DATE	APP.
A	NEW DRAWING PER ECO 2576	12/16/2014	JMB
B	ECO 3020	11/26/2015	JMB
C	MOVE 68-022-51 68-022-52 TO INSIDE ECO 3021	10/12/2016	JMB
D	ADD CENTER OF MASS AND AS BUILT DRY WEIGHT ECO 3020	10/12/2016	JMB
E	ADDED GREASE FITTING AND OTHER MISC ITEMS PER ECO 3201	11/30/2017	HM
F	WAS 68-108-00, ECO 3500	2/5/2018	BC
G	ADD CHUTE HYD HOSE CLAMP (2) LABELS AND BANGLES, UPDATED REFERENCE DIMENSIONS, CHANGES PER ECO 3704	4/18/2019	HM
H	BOM UPDATED, VIEW DELETED, VIEWS UPDATED, CHANGES PER ECO 4001	3/23/2020	BJ

FOR REVIEW

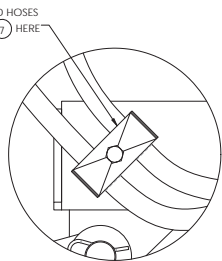
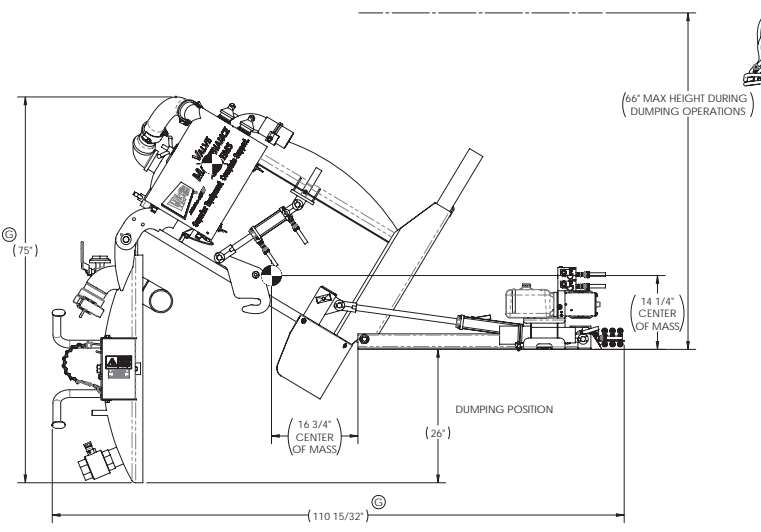
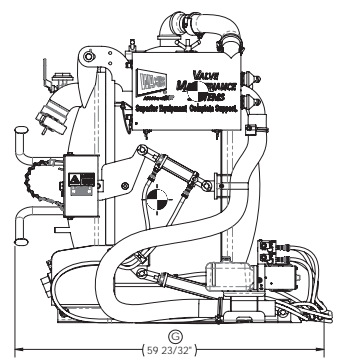
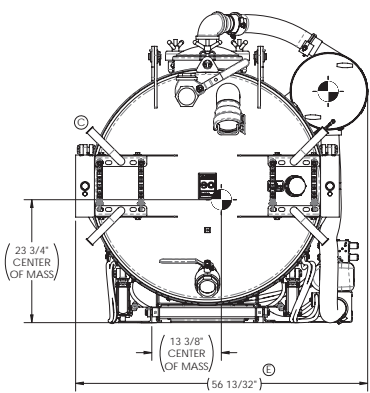
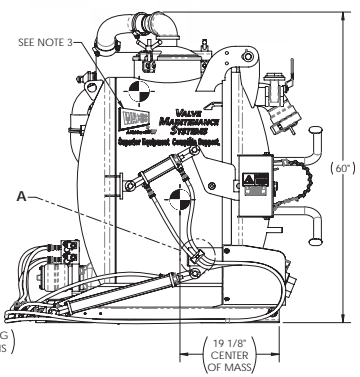
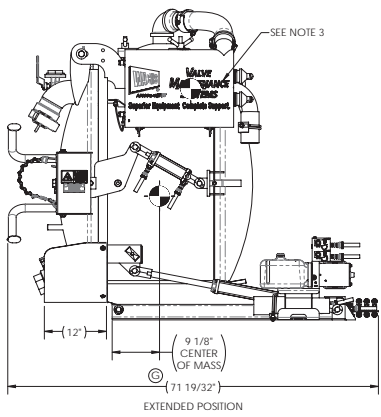
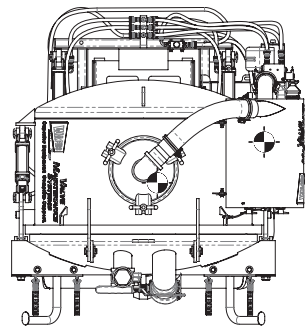
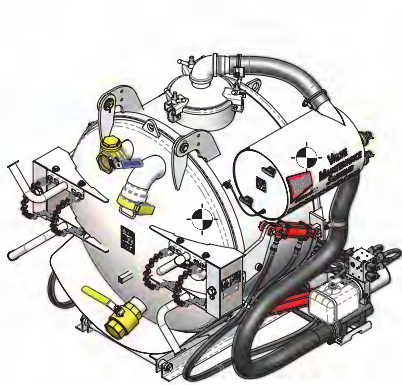

DETAIL A
SCALE 1 : 2
BOTH SIDES

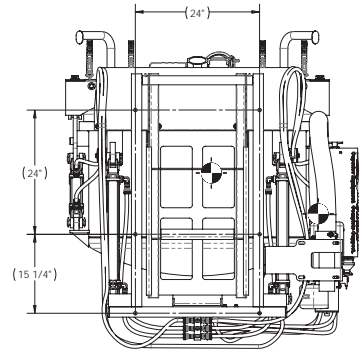

		E. H. WACHS Utility Products 600 Knightbridge Parkway Lynchburg, VA 24504 www.ehwachs.com	
TITLE: ASSEMBLY, 150 GAL SPOILS TANK			
DRAWN BY: JMB DATE: 12/16/2014	APPROVED BY: RMW DATE: 04/12/2015	SCALE: 1:12 SHEET: 1 OF 4	REV. NO.: 77-433-02

ITEM	PART NUMBER	QTY	DESCRIPTION	LENGTH
1	67-093-02	1	CLAMP, 4" BANDLOCK	
2	67-093-03	1	GASKET, 4" BANDLOCK COUPLER	
3	67-093-06	1	PLUG, 4" MALE	
4	68-022-51	2	WELDMENT, RH BRACKET	
5	68-022-52	2	WELDMENT, LH BRACKET	
6	68-034-12	1	ELBOW, 3" NPT	
7	68-103-00	2	HYDRAULIC CYLINDER, 4" STROKE	
8	68-113-00	1	SITE EYE GLASS AND O-RING	
9	68-114-01	1	ALUMINUM CARTRIDGE BODY	
10	68-114-00	1	CARTRIDGE, FLOW DIVIDER	
11	68-121-01	3	NUT, BULKHEAD LOCK	
12	68-126-01	2	DOOR HINGE, CLAMP COLLAR 25mm	
13	68-132-00	1	HYDRAULIC POWER UNIT - 12 VDC	
14	68-134-00	1	NIPPLE, 3" NPT X 3" COMBINATION HOSE	
15	68-153-10	1	SCREEN, 3.5625 x .20 MESH SS	
16	68-153-00	1	VALVE, 3" BALL	
17	68-158-57	4	HOSE CLAMP, 3" SPIRAL, CLOCKWISE	
18	68-160-03	1	HOSE, 3" VACUUM, BLACK	1.5
19	68-160-03	1	HOSE, 3" VACUUM, BLACK	6.75'
20	77-015-01	2	HYDRAULIC CYLINDER, 18" STROKE	
21	77-074-00	1	WELDMENT, RAIL	
22	77-075-18	1	HPU MOUNT	
23	77-075-20	1	CHUTE	
24	77-075-00	1	SUPPORT FRAME, TANK	
25	77-160-05	1	LABEL, EYE AND EAR PROTECTION	
26	77-160-10	2	LABEL, PINCH POINT	
27	77-160-25	2	LABEL, HEAVY DOOR	
28	77-180-00	1	BAR, PIVOT	
29	77-209-02	1	CLAMP, 3.5" OD	
30	77-280-63	1	VALVE, 3" GATE	
31	77-290-42	1	LABEL, 150 GAL TANK SPOILS WEIGHT	
32	77-290-45	1	LABEL, SPOILS TANK LEVEL 60%	
33	77-431-03.00	1	FILTER ASSEMBLY	
34	77-433-03	1	150 GAL SPOILS TANK AND DOOR ASSEMBLY	
35	77-620-00.01	2	19 1/2" HOSE ASSEMBLY, -.06 FJ X -.06 FJ X -.06 HOSE	
36	77-620-00.02	2	41 1/2" HOSE ASSEMBLY, -.06 FJ X -.06 FJ X -.06 HOSE	
37	77-631-00.01	2	99 1/2" HOSE ASSEMBLY, -.06 FJ X -.06 FJ X -.06 HOSE	
38	77-631-00.02	1	126 1/2" HOSE ASSEMBLY, -.06 FJ X -.06 FJ X -.06 HOSE	
39	77-631-00.07	1	90 1/2" HOSE ASSEMBLY, -.06 FJ X -.06 FJ X -.06 HOSE	
40	77-631-00.08	4	34 1/2" HOSE ASSEMBLY, -.06 FJ X -.06 FJ X -.06 HOSE	
41	79-102-11	4	SUCTION HOSE BUNGEE	
42	90-046-91	2	PIN, 3/16 X 2 COTTER	
43	90-051-05	4	HHCS, 1/4-20 X 1/2	
44	90-051-10	1	HHCS, 1/4-20 X 1	
45	90-051-20	2	HHCS, 1/4-20 X 2 GRADE 5 Zn	
46	90-054-05	2	SSS, 1/4-20 X 1/2 CUIP PI	
47	90-055-01	3	NUT, 1/4-20 HEX	
48	90-055-18	1	NUT, 1/4-20 ACORN	
49	90-055-52	7	WASHER, 1/4 SPLIT RING	
50	90-055-53	6	WASHER, FLAT, 1/4	
51	90-055-57	4	WASHER, 1/4 x 1 OD FENDER 18-8SS	
52	90-071-12	2	HHCS, 3/8-16 X 1-1/4 GRADE 5	
53	90-075-01	2	NUT, 3/8-16 HEX GR 5 Zn	
54	90-075-52	4	WASHER, 3/8 SPLIT RING	
55	90-075-53	4	WASHER, 3/8 FLAT	
56	90-091-17	8	HHCS, 1/2-13 X 1-3/4	
57	90-095-01	8	NUT, 1/2"-13 HEX GRADE 8	
58	90-095-52	16	WASHER, 1/2 FLAT	
59	90-095-58	8	WASHER, 1/2 SPLIT RING	
60	90-500-05	2	GREASE FITTINGS, 1/4-28 STRAIGHT	
61	910-6-8-C50X-S	4	ADAPTER, -.08 ORB-M (3/4-16) X -.06 JIC-M (9/16-18) 90 DEG	
62	910-6-8-F50X-S	5	ADAPTER, -.08 ORB-M (3/4-16) X -.06 JIC-M (9/16-18)	
63	910-6-F50X-S	6	ADAPTER, -.06 JIC-M (9/16-18) X -.06 ORB-M (9/16-18)	
64	910-6-WJTX-S	3	TEE, -.06 JIC-M (9/16-18)	

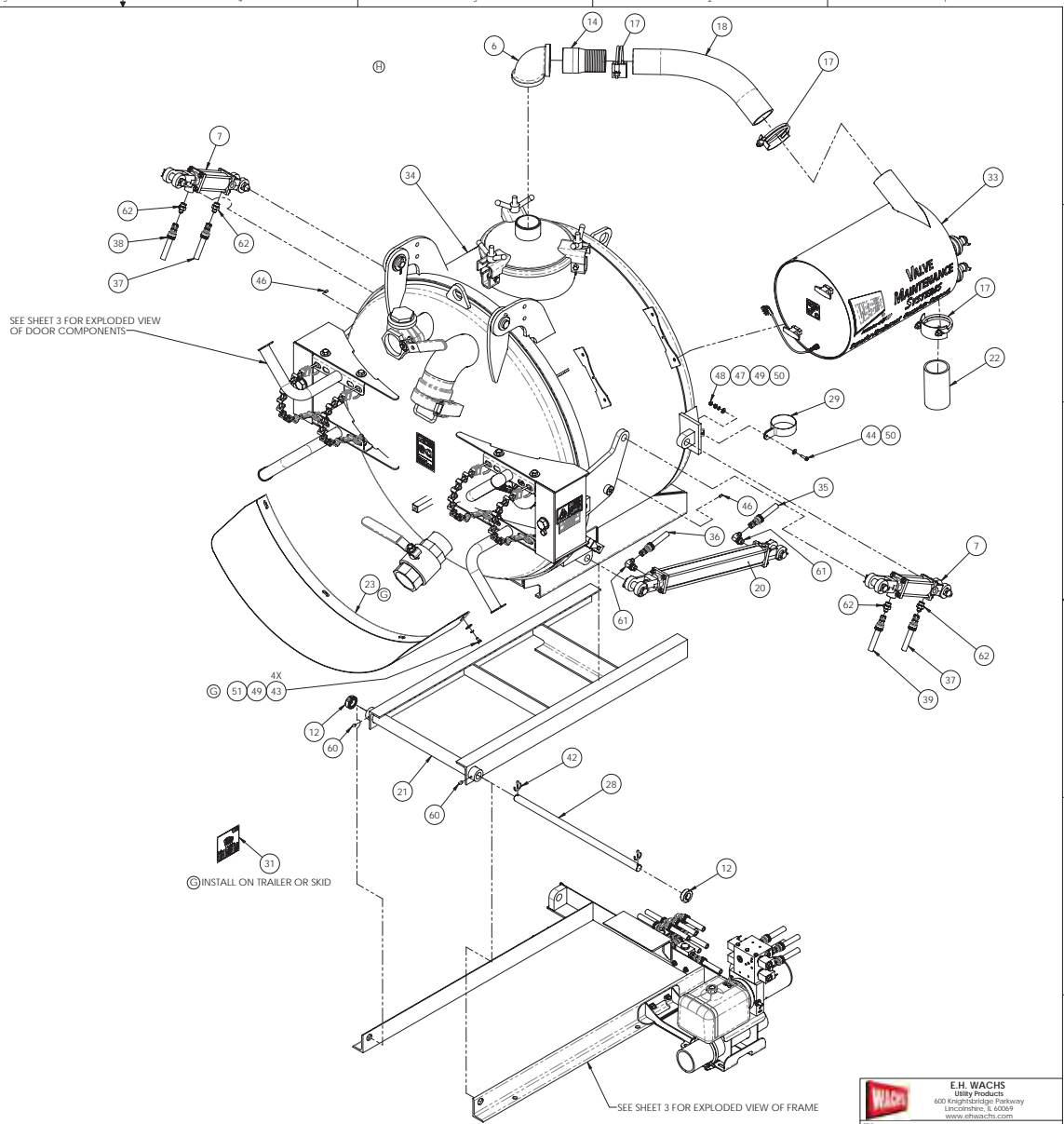

E.H. WACHS Utility Products 600 Knightbridge Parkway Lincolnshire, IL 60069 www.ehwachs.com	
DATE: 12/16/2014	APPROVED BY: BMW
SCALE: 1:12	SHEET: 2 OF 4
77-433-02	

	PREPARED BY: JMB CHECKED BY: JMB DATE: 12/16/2014 SCALE: 1:12 SHEET: 2 OF 4
--	---

SCALE 1:8

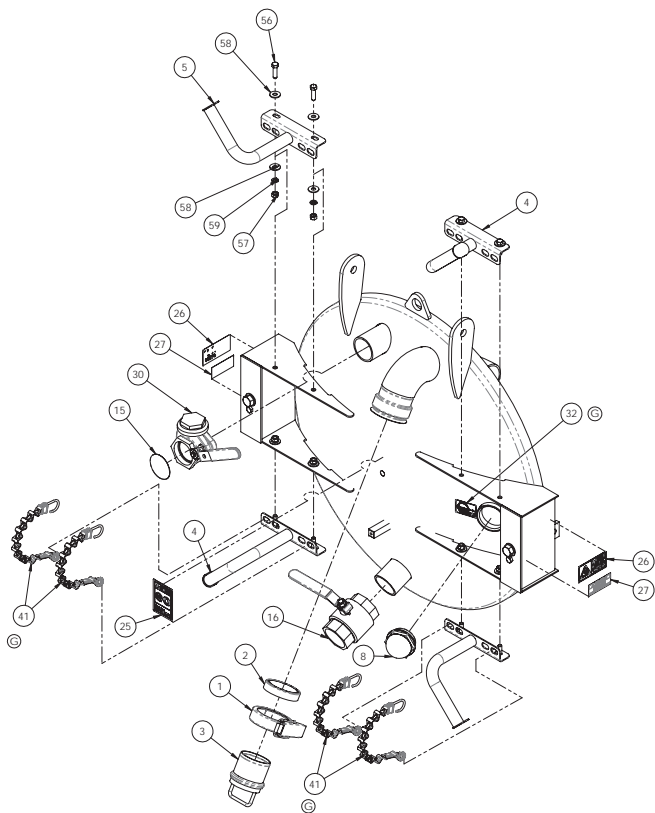

DOOR EXPLODE
SCALE 1:8

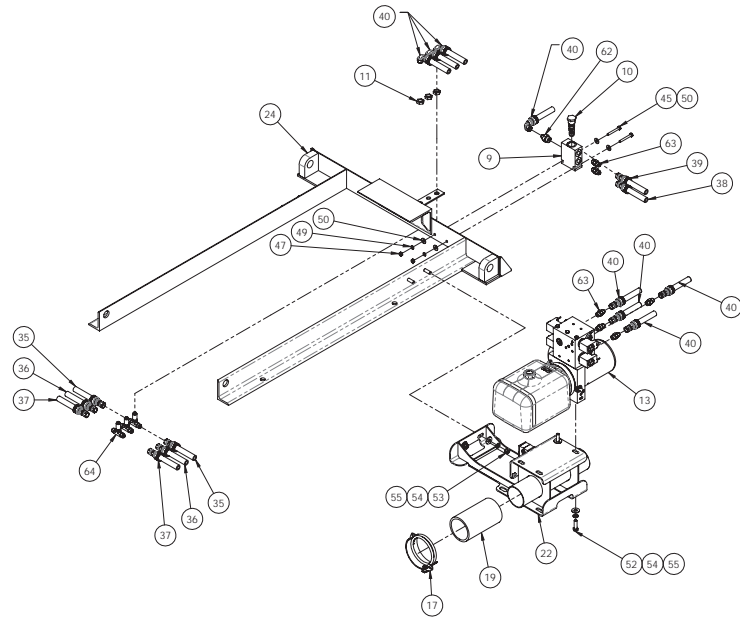

FRAME EXPLODE
SCALE 1:8

 E.H. WACHS Utility Products 600 Knightbridge Parkway Lincolnshire, IL 60069 www.ehwachs.com	
TITLE: ASSEMBLY, 150 GAL SPOILS TANK	
DRAWN BY: JMB	APPROVED BY: RMW
DATE: 12/16/2014	SCALE: 1:12
SHEET: 3 OF 4	DATE: 04/12/2015
REV: H	77-433-02

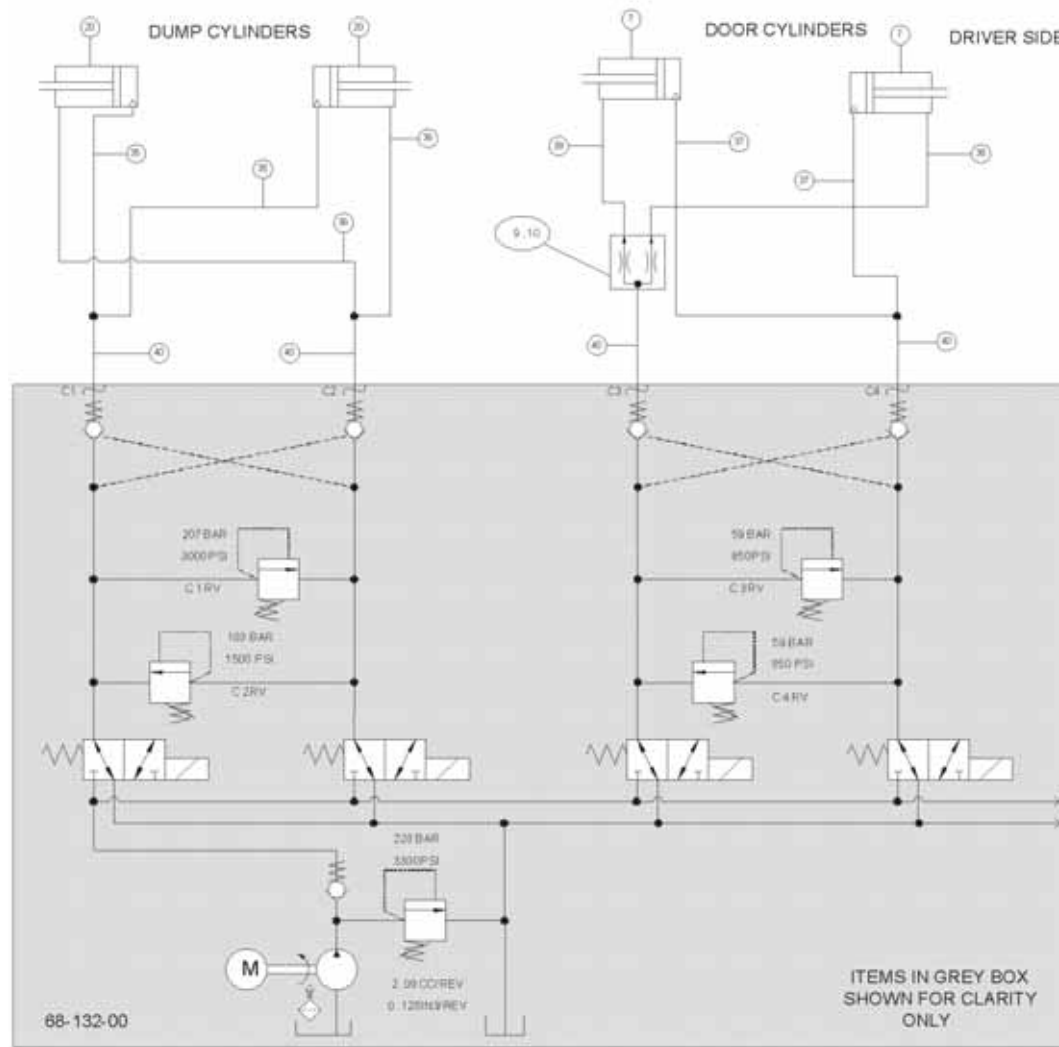

HYDRAULIC SCHEMATIC ©

		E.H. WACHS Utility Products 600 Knightbridge Parkway Lincolnshire, IL 60069 www.ehwachs.com	
TITLE ASSEMBLY, 150 GAL SPOILS TANK			
DRAWN BY JMB	APPROVED BY BMW	SCALE 1:12	DATE 04/12/2015
CHECKED BY JMB	DATE 12/16/2014	SHEET 4 OF 4	REV. H
PART NUMBER 77-433-02		DRAWING NO. 77-433-02	

- NOTES:
1. MATERIAL: PER COMPONENT
 2. FINISH: PER COMPONENT
 3. SEE WELDMENTS 77-432-01-00 AND 77-431-03-10 FOR DECAL 77-160-90 PLACEMENT
 4. REFER TO SCHEMATIC SHEET 4 REGARDING HOSE ROUTING DETAILS
 5. USE THREAD SEALANT ON ALL FASTENERS
 6. LIBERALLY APPLY GREASE TO ALL FRICTION LOCATIONS
 7. APPROX WEIGHT: 1200 LB (C)

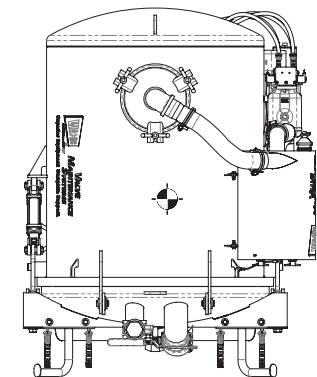
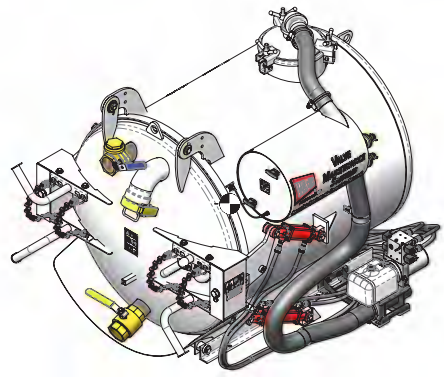

REVISION HISTORY			
REV	DESCRIPTION	DATE	APR
A	CHANGED FILTER ASSEMBLY PER ECO 02101	8/31/2011	GLD
B	UPDATED MODEL DRAWING ECO 2576	11/11/2014	JMB
C	ECO 3020	11/20/2015	JMB
D	MOVE 68-022-01, 68-022-52 INSIDE ECO 3031	12/3/2015	JMB
E	ADD CENTER OF MASS AND ASSEMBLY DRY WEIGHT ECO 3550	1/7/2016	JMB
F	UPDATE 77-432-01-00 ECO 3056	1/21/2016	JMB
G	HOSE CHANGE ECO 3201	5/15/2017	HMA
H	WAS 68-108-00 ECO 3550	3/5/2018	EC
J	ADD CHECK HYD HOSE CLAMP TIGHTENING RANGES, UPDATED REFERENCE DIMENSIONS CHANGES PER ECO 370	4/18/2019	HMA
K	BOM UPDATED, VIEW DELETED, VIEWS UPDATED, CHANGES PER ECO 4001	3/27/2020	RJ

FOR REVIEW

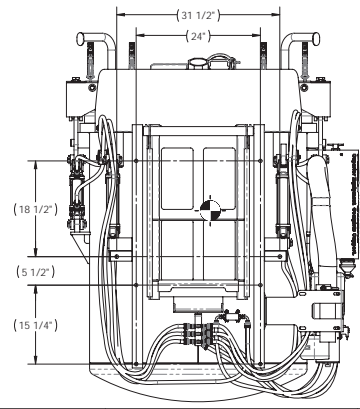
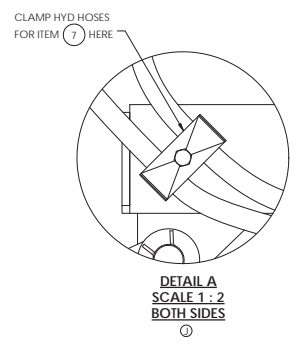
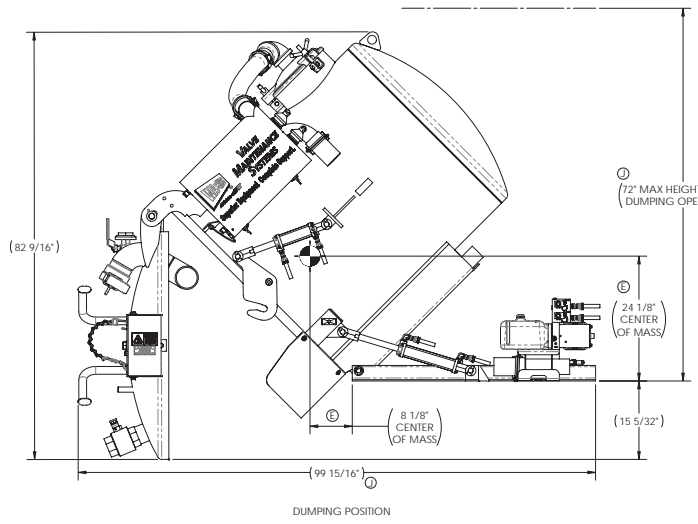
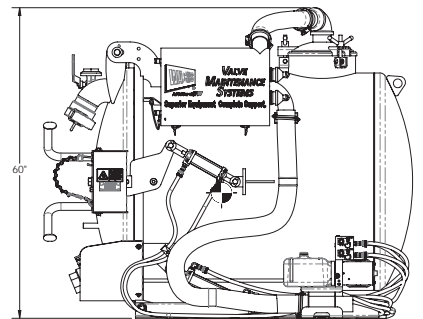
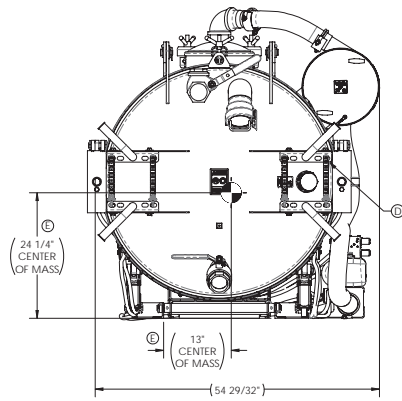
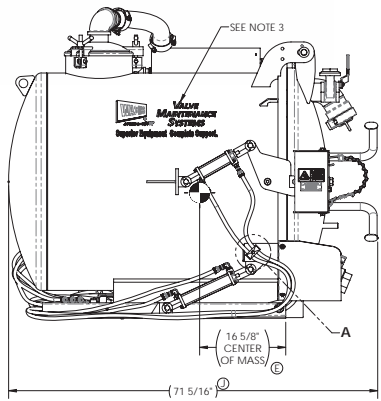
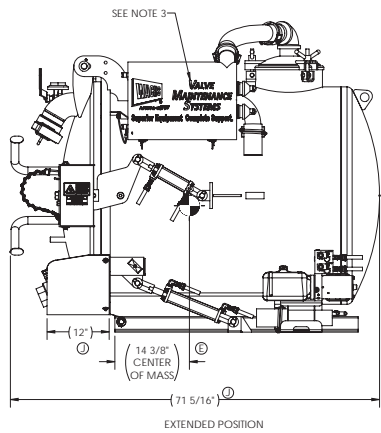

		E. H. WACHS Utility Products 600 Knightbridge Parkway Lincolnshire, IL 60069 www.ehwachs.com	
TITLE: ASSEMBLY, 350 GALLON TANK			
DATE: 3/21/09	APPROVED BY: SMV	SCALE: 1:12	
DATE: 8/24/09	DATE: 8/24/09	SHEET: 1 OF 4	REV: 1
DATE: 7/27/10	DATE: 7/27/10		
DRAWN BY: [Signature]		CHECKED BY: [Signature]	
DESIGNED BY: [Signature]		APPROVED BY: [Signature]	
77-432-02-00			

ITEM NO.	PART NUMBER	QTY	DESCRIPTION	LENGTH	
1	67-093-02	1	CLAMP, 4" BANDLOCK		
2	67-093-03	1	GASKET, 4" BANDLOCK COUPLER		
3	67-093-06	1	PLUG, 1" MALE		
4	68-022-51	2	WELDMENT, RH BRACKET		
5	68-022-52	2	WELDMENT, LH BRACKET		
6	68-034-12	1	ELBOW, 3" NPT		
7	68-103-00	2	HYDRAULIC CYLINDER, 4" STROKE		
8	68-113-00	1	SITE EYE GLASS AND O-RING		
9	68-114-01	1	ALUMINUM CARTRIDGE BODY		
10	68-114-00	1	CARTIRIDGE, FLOW DIVIDER		
11	68-121-01	3	NUT, BULKHEAD LOCK		
12	68-126-01	2	DOOR HINGE, CLAMP COLLAR 25mm		
13	68-132-00	1	HYDRAULIC POWER UNIT - 12 VDC		
14	68-134-00	1	NIPPLE, 3" NPT X 3" COMBINATION HOSE		
15	68-153-10	1	SCREEN, 3.5625 x .20 MESH SS		(C)
16	68-153-00	1	VALVE, 3" BALL		(C)
17	68-158-57	4	HOSE CLAMP, 3" SPIRAL, CLOCKWISE		(C)
18	68-160-03	1	HOSE, 3" VACUUM, BLACK	2.66'	(C)
19	68-160-03	1	HOSE, 3" VACUUM, BLACK	6.75'	(C)
20	77-075-18	1	HPU MOUNT		(D)
21	77-075-20	1	CHUTE		(D)
22	77-160-05	1	LABEL, EYE AND EAR PROTECTION		(D)
23	77-160-10	2	LABEL, PINCH POINT		(D)
24	77-160-25	2	LABEL, HEAVY DOOR		(D)
25	77-180-00	1	BAR, PIVOT		(E)
26	77-209-02	1	CLAMP, 3.5" OD		(E)
27	77-251-04	2	47 1/2" HOSE ASSEMBLY, -06 FJ X -06 FJ X -06 HOSE		(E)
28	77-251-05	2	58 1/2" HOSE ASSEMBLY, -06 FJ X -06 FJ X -06 HOSE		(E)
29	77-251-07	2	103 1/2" HOSE ASSEMBLY, -06 FJ X -06 FJ X -06 HOSE		(E)
30	77-252-01	1	100 1/2" HOSE ASSEMBLY, -06 FJ X -06 FJ X -06 HOSE		(E)
31	77-252-02	1	116 1/2" HOSE ASSEMBLY, -06 FJ X -06 FJ X -06 HOSE		(E)
32	77-252-03	4	39 1/2" HOSE ASSEMBLY, -06 FJ X -06 FJ X -06 HOSE		(E)
33	77-280-63	1	VALVE, 3" GATE		(E)
34	77-290-43	1	LABEL, 350 GAL TANK SPOILS WEIGHT		(E)
35	77-290-45	1	LABEL, SPOILS TANK LEVEL 60%		(E)
36	77-431-03-00	1	FILTER ASSEMBLY		(E)
37	77-432-02-01	1	350 GAL SPOILS TANK AND DOOR ASSEMBLY		(E)
38	77-432-04-00	1	RAIL WELDMENT, TANK		(E)
39	77-432-05-00	1	WELDMENT, SUPPORT FRAME		(E)
40	79-102-11	4	SUCTION HOSE BUNGEE		(E)
41	90-046-91	2	PIN, 3/16 X 2 COTTER		(E)
42	90-051-06	4	HHCS, 1/4-20 X 5/8 GRADE 5		(E)
43	90-051-10	1	HHCS, 1/4-20 X 1		(E)
44	90-051-20	2	HHCS, 1/4-20 X 2 GRADE 5 Zn		(E)
45	90-054-05	2	SSS, 1/4-20 X 1/2 CUP PT		(E)
46	90-055-01	3	NUT, 1/4-20 HEX		(E)
47	90-055-18	1	NUT, 1/4-20 ACORN		(E)
48	90-055-52	7	WASHER, 1/4 SPLIT RING		(E)
49	90-055-53	6	WASHER, FLAT, 1/4		(E)
50	90-055-57	4	WASHER, 1/4 X 1 OD FENDER 18-8SS		(E)
51	90-071-12	2	HHCS, 3/8-16 X 1-1/4 GRADE 5		(E)
52	90-075-01	2	NUT, 3/8-16 HEX GR 5 ZN		(E)
53	90-075-52	4	WASHER, 3/8 SPLIT RING		(E)
54	90-075-53	4	WASHER, 3/8 FLAT		(E)
55	90-091-17	8	HHCS, 1/2-13 X 1-3/4		(E)
56	90-095-01	8	NUT, 1/2-13 HEX GRADE 8		(E)
57	90-095-52	16	WASHER, 1/2 FLAT		(E)
58	90-095-58	8	WASHER, 1/2 SPLIT RING		(E)
59	90-500-05	2	GREASE FITTING, 1/4-28 STRAIGHT		(E)
60	910-6-8-C5CX-S	4	ADAPTER, -08 ORB-M (3/4-16) X -06 JIC-M (9/16-18) 90 DEG		(E)
61	910-6-8-F5CX-S	5	ADAPTER, -08 ORB-M (3/4-16) X -06 JIC-M (9/16-18)		(E)
62	910-6-F5CX-S	6	ADAPTER, -06 JIC-M (9/16-18) X -06 ORB-M (9/16-18)		(E)
63	910-6-WJIX-S	3	TEE, -06 JIC-M (9/16-18)		(E)
64	915-639617	2	HYDRAULIC CYLINDER, 8" STROKE		(E)

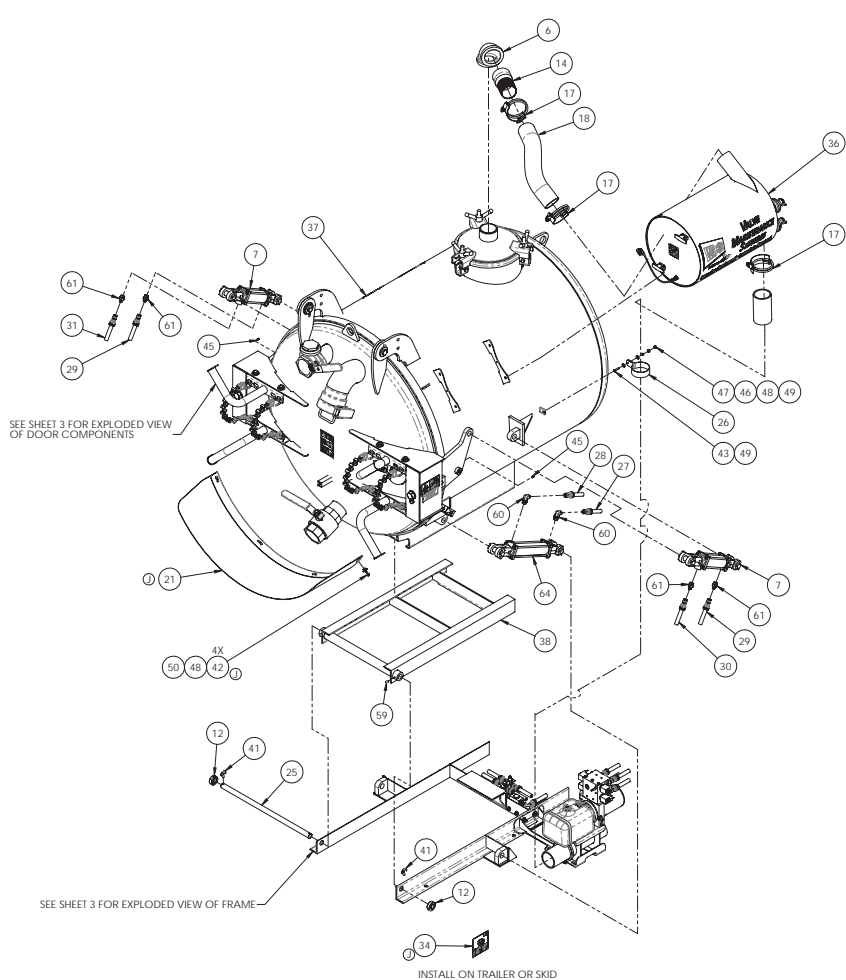

SEE SHEET 3 FOR EXPLODED VIEW OF DOOR COMPONENTS

SEE SHEET 3 FOR EXPLODED VIEW OF FRAME

INSTALL ON TRAILER OR SKID

		E.H. WACHS Utility Products 600 Knightbridge Parkway Lincolnshire, IL 60069 www.ehwachs.com	
ASSEMBLY, 350 GALLON TANK			
DATE	3/21/09	APPROVED BY	SMW
SCALE	1:12	DATE	8/24/09
SHEET	2 OF 4	REV.	K
PART NO. 77-432-02-00		REV. K	

	This drawing is a WACHS COMPANY drawing. It is the property of Wach's Company and is not to be reproduced, stored in a retrieval system, or transmitted in any form or by any means, electronic, mechanical, photocopying, recording, or by any information storage and retrieval system, without the prior written permission of Wach's Company.
PROPOSED AND CONTROLLED BY: WACHS COMPANY DATE: 3/21/09 USER: D	APPROVED BY: SMW DATE: 8/24/09 USER: D

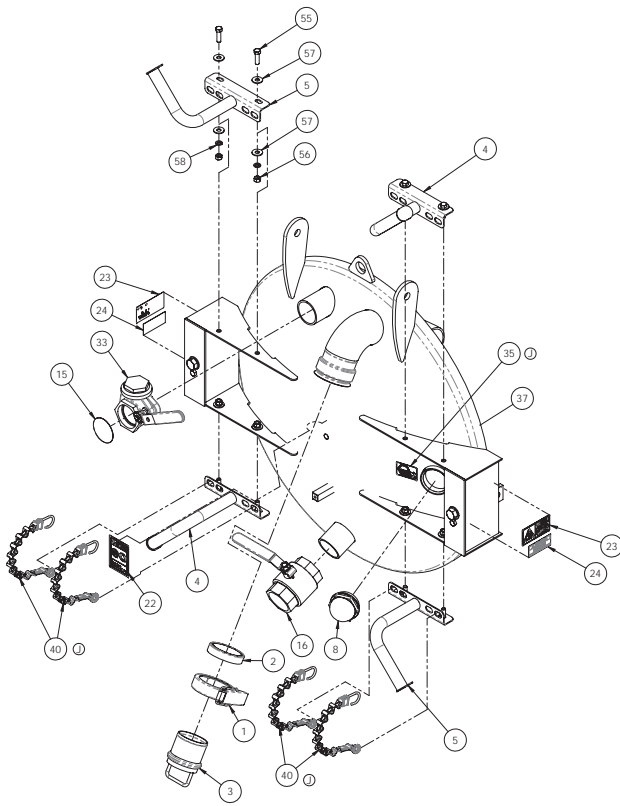

DOOR EXPLODE
SCALE 1:8

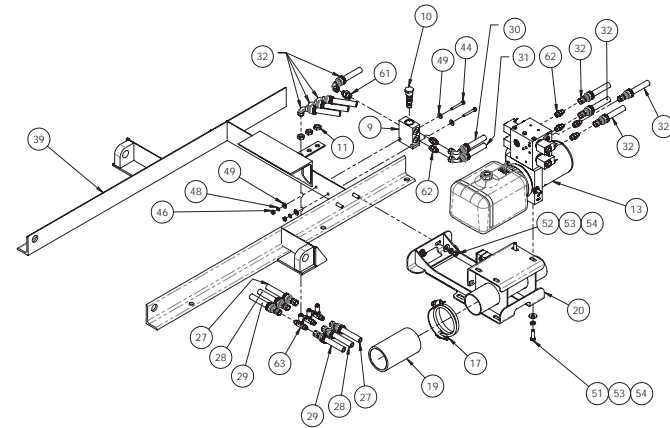

FRAME EXPLODE
SCALE 1:8



MANUFACTURED BY
E.H. WACHS
600 Knightbridge Parkway
Lincolnshire, IL 60069
www.ehwachs.com

E.H. WACHS
Utility Products
600 Knightbridge Parkway
Lincolnshire, IL 60069
www.ehwachs.com

TITLE			
ASSEMBLY, 350 GALLON TANK			
DESIGNED BY	DAI	APPROVED BY	SMV
DATE	3/21/09	DATE	8/24/09
SHEET	3	OF	4
REV.			
			K

77-432-02-00

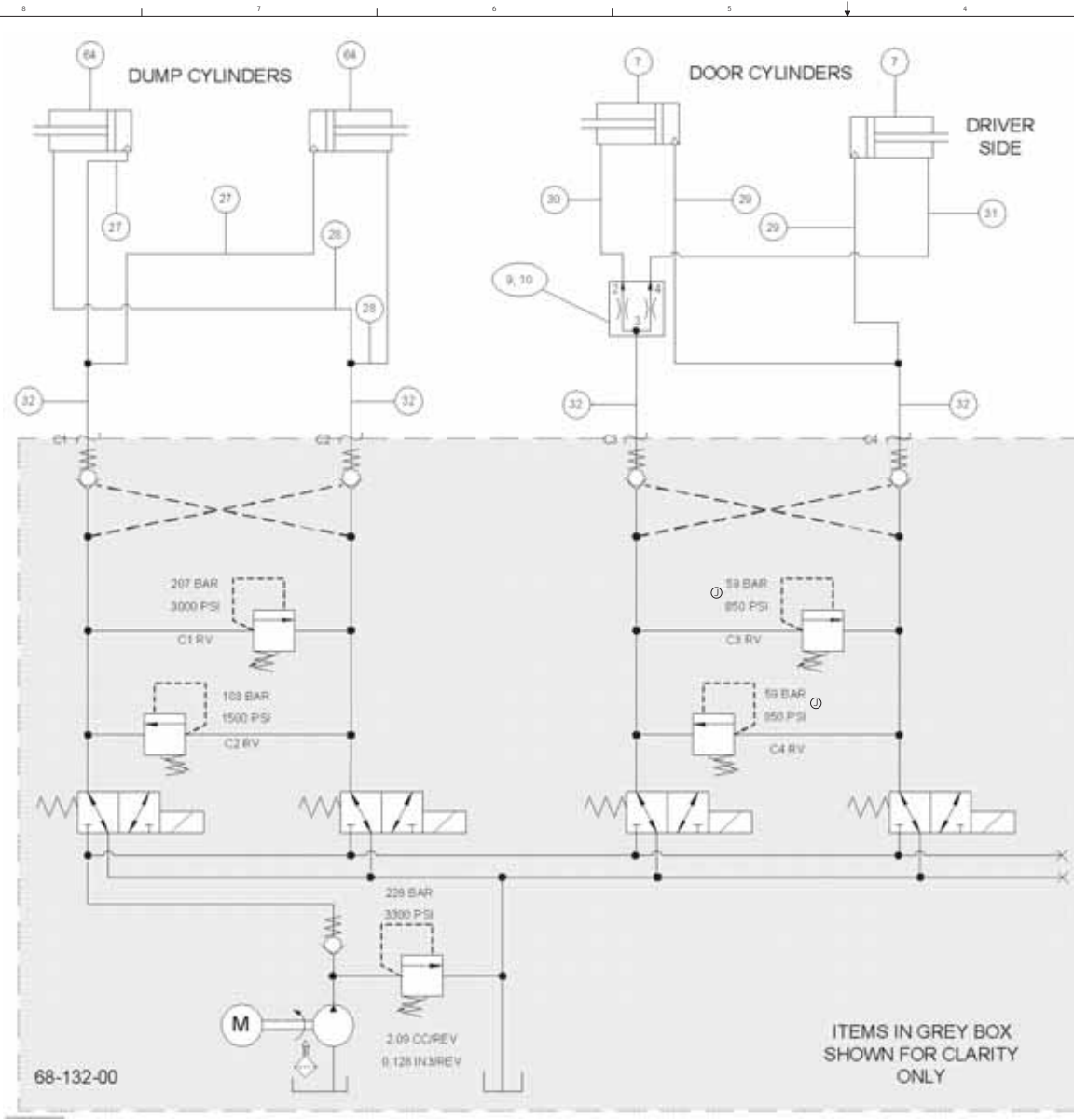

HYDRAULIC SCHEMATIC

©

		E.H. WACHS Utility Products 600 Knightbridge Parkway Lincolnshire, IL 60069 www.ehwachs.com	
		ASSEMBLY, 350 GALLON TANK	
DRAWN BY DAL	APPROVED BY SMV	SCALE 1:12	
DATE 7/21/09	DATE 8/24/09	SHEET 4 OF 4	
SIZE D	TITLE NO. 77-432-02-00		REV. K